

6.5A_{RMS} VBUS OVP Load Switch for 28V EPR Systems

Features

- 3V to 33V Operating Voltage Range
- 39VDC Abs. Max. Rating at VBUS and 35V at VSYS
- 6.5A Continuous Current Rating
- 24mΩ typ. On-Resistance from VBUS to VSYS
- Soft-Start (SS) Limits Inrush Current
- Over-Voltage Protection (OVP) at VBUS
 - ▶ 33V, 100ns Internally Fixed
 - ▶ 4V to 33V External Resistor Programmable
- Over-Voltage Protection (OVP) latch off at VCHSYS
 - ▶ 4V to 28V External Resistor Programmable
- “Ideal Diode” Reverse-Current Protection (RCP, KTS1897A/B only)
 - ▶ $V_F = 20\text{mV}$ and $15\mu\text{s}$ Fast Recovery
- Bi-directional Mode when enabled (KTS1897C/D only)
- Reverse blocking when disabled
- Short-Circuit Protection (SCP) at VBUS & VSYS
- Over-Current Protection (OCP)
- Over-Temperature Protection (OTP)
- $\overline{\text{EN}}$ (KTS1897A/C) or EN (KTS1897B/D) Enable Logic
- Hiccup Mode Auto-Retry after Faults
- -40°C to 85°C Operating Temperature Range
- 20-bump WLCSP 2.56 x 2.00mm (0.5mm pitch)

Brief Description

The KTS1897 is a USB VBUS safety management load switch for up to 182W current-sink input for 28V EPR systems. The input operating range is 3V to 33V with VBUS withstand up to 39VDC and VSYS up to 35VDC. Ultra-fast over-voltage protection (OVP) is internally set to 33V, but optionally adjusted via external resistors. Low on-resistance minimizes heat and voltage droop.

KTS1897A/B has automatic reverse-current protection (RCP) feature which acts as an “ideal diode” with fast recovery and isolates VBUS when charging or powering the system via another port. KTS1897C/D supports bi-directional mode when enabled. Additional safety management includes short-circuit protection (SCP) during soft-start, Over-Current Protection (OCP) and over-temperature protection (OTP).

The KTS1897 is packaged in advanced, fully “green” compliant, 2.56mm x 2.00mm, 20-bump Wafer-Level Chip-Scale Package (WLCSP).

Applications

- Notebooks, Gaming PCs
- Mini Desktop PCs, Docking Stations, Monitors

Typical Application

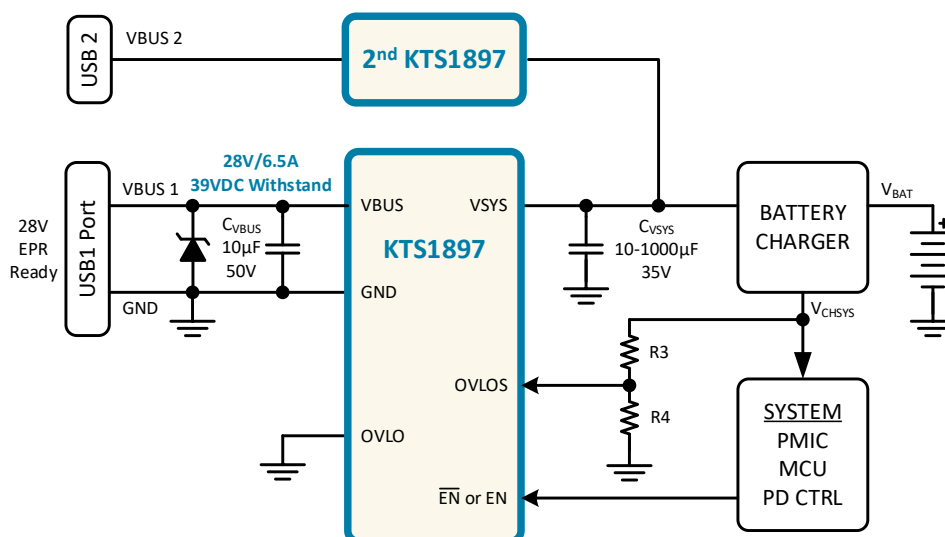

Ordering Information

Part Number	Marking ¹	Enable Polarity	Switch Mode	Package
KTS1897AEIAD-TA ²	__YWZNAABB	\overline{EN}	Uni-directional with RCP	WLCSP-20
KTS1897BEIAD-TA	VCYWZNAABB	EN	Uni-directional with RCP	WLCSP-20
KTS1897CEIAD-TA ²	__YWZNAABB	\overline{EN}	Bi-directional without RCP	WLCSP-20
KTS1897DEIAD-TA	VFYWZNAABB	EN	Bi-directional without RCP	WLCSP-20

Pinout Diagram

WLCSP54-20



20-bump 2.560mm x 2.000mm x 0.555mm
WLCSP Package, 0.500mm pitch

Top Mark

XX = Device ID, YW = Date Code, ZN = Assembly Code, AABB = Serial Number

Pin Descriptions

Pin #	Name	Function
A1, A2, A3, A4, B1, B2, B3, B4	VSYS	Power Switch System-Side Connection – connect to system internal power rail.
C1, C2, C3, C4, D1, D2, D3, D4	VBUS	Power Switch Port-Side Connection – connect to VBUS on USB power port.
E1	\overline{EN}	Enable – active-low logic input (KTS1897A/C)
	EN	Enable – active-high logic input (KTS1897B/D)
E2	OVLO	External OVLO Adjustment – connect to GND to use the internally fixed OVLO threshold. Connect an external resistive voltage divider from VBUS to OVLO to GND to adjust the OVLO threshold.
E3	OVLOS	OVLOS Adjustment – Connect an external resistive voltage divider from VCHSYS to OVLOS to GND to adjust the OVLOS threshold. Connect to GND if not used.
E4	GND	Ground

1. “VC” or “VF” is the Device ID, “YW” is the Date Code, “ZN” is the Assembly Code, and “AABB” is the Serial Number.
2. Consult Kinetic Technologies authorized representative for availability.

Absolute Maximum Ratings³

Symbol	Description	Value	Units
V _{BUS}	V _{BUS} to GND (continuous)	-0.3 to 39	V
	V _{BUS} to GND (during IEC61000-4-5 surge event with external TVS)	-5 to 45	
V _{SYS}	V _{SYS} to GND	-0.3 to 35	V
V _{BUS-SYS}	V _{BUS} to V _{SYS}	-34 to 39	V
V _{EN} , V _{EN}	EN, EN to GND	-0.3 to V _{BUS}	V
V _{OVLO}	OVLO to GND	-0.3 to V _{BUS}	V
V _{OVLOS}	OVLOS to GND	-0.3 to 30	V
I _{SW}	Maximum Switch Current (continuous)	6.5	A
	Peak Switch Current (5ms and P _D limited)	15	
T _J	Die Junction Operating Temperature Range	-40 to 150	°C
T _S	Storage Temperature Range	-55 to 150	°C
T _{LEAD}	Maximum Soldering Temperature (at leads, 10 sec)	260	°C

ESD Ratings⁴

Symbol	Description	Value	Units
V _{ESD_HBM}	JEDEC JS-001-2017 Human Body Model (all pins)	±2	kV

Thermal Capabilities⁵

Symbol	Description	Value	Units
Θ _{JA}	Thermal Resistance – Junction to Ambient	54.1	°C/W
P _D	Maximum Power Dissipation at T _A ≤ 25°C (T _J = 125°C)	1.85	W
ΔP _D /ΔT	Derating Factor Above T _A = 25°C	-18.5	mW/°C

- Stresses above those listed in Absolute Maximum Ratings may cause permanent damage to the device. Functional operation at conditions other than the operating conditions specified is not implied. Only one Absolute Maximum rating should be applied at any one time.
- ESD Ratings conform to JEDEC and IEC industry standards. Some pins may actually have higher performance.
- Junction to Ambient thermal resistance is highly dependent on PCB layout. Values are based on thermal properties of the device when soldered to an EV board.

Recommended Operating Conditions⁶

Symbol	Description	Value	Units
V _{BUS} , V _{SYS}	VBUS, VSYS Operating Voltage	3 to 33	V
V _{OVLOS}	OVLOS Adjust Input Bias Voltage	0 to 5.5	V
V _{OVLO}	OVLO Adjust Input Bias Voltage	0 to 5.5	V
V _{EN}	Enable Logic Input Voltage	0 to 33	V
T _A	Ambient Operating Temperature Range	-40 to 85	°C
T _J	Die Junction Operating Temperature Range	-40 to 125	°C
C _{VBUS}	VBUS External Local Capacitance (nominal)	1 to 10	μF
		50	V
C _{VSYS}	VSYS External Capacitance (nominal)	10 to 1000	μF
		35 or 50	V
T _A	Ambient Operating Temperature Range	-40 to 85	°C
T _J	Die Junction Operating Temperature Range	-40 to 125	°C

Electrical Characteristics⁷

Unless otherwise noted, the *Min* and *Max* specs are applied over the full operation range of T_J = -40°C to +125°C and V_{BUS} = 3V to 33V or V_{SYS} = 3V to 33V. Typical values are specified at T_A = +25°C with V_{BUS} = 5V or V_{SYS} = 5V.

Supply Specifications

Symbol	Description	Conditions	Min	Typ	Max	Units
V _{BUS}	VBUS Supply Operating Voltage Range		3		33	V
V _{SYS}	VSYS Supply Operating Voltage Range		3		33	V
V _{UVLO}	Under-Voltage Lockout	V _{BUS} rising threshold		2.7	2.9	V
		V _{SYS} rising threshold (KTS1897C/D)		2.7	2.9	V
		Hysteresis		160		mV
I _Q	No-Load Supply Current (Enabled)	V _{BUS} = 5V, V _{SYS} = open		240		μA
		V _{BUS} = 28V, V _{SYS} = open		290		
	No-Load Supply Current (Enabled, KTS1897C/D in I _{SOURCE} Mode)	V _{SYS} = 5V, V _{BUS} = open		290		
		V _{SYS} = 28V, V _{BUS} = open		420		
I _{SHDN}	Shutdown Supply Current	V _{BUS} = 5V, V _{SYS} = open		1		μA
		V _{BUS} = 28V, V _{SYS} = open		3		μA
	Shutdown Supply Current (KTS1897C/D in I _{SOURCE} Mode)	V _{SYS} = 5V, V _{BUS} = open		1		μA
		V _{SYS} = 28V, V _{BUS} = open		3		μA
I _{SYS_RCP}	Output Supply Current in RCP	Enabled, V _{BUS} = 0V, V _{SYS} = 5V		150		μA

(continued next page)

- The recommended Operating Conditions table defines the conditions for actual device operation. Recommended operating conditions are specified to ensure optimal performance to the datasheet specifications. Kinetic does not recommend exceeding them or designing to Absolute Maximum Rating.
- Device is guaranteed to meet performance specifications over the -40°C to +85°C operating temperature range by design, characterization, and correlation with statistical process controls.

Electrical Characteristics (continued)⁸

Unless otherwise noted, the *Min* and *Max* specs are applied over the full operation range of $T_J = -40^{\circ}\text{C}$ to $+125^{\circ}\text{C}$ and $V_{BUS} = 3\text{V}$ to 33V or $V_{SYS} = 3\text{V}$ to 33V . Typical values are specified at $T_A = +25^{\circ}\text{C}$ with $V_{BUS} = 5\text{V}$ or $V_{SYS} = 5\text{V}$.

Logic Pin Specifications

Symbol	Description	Conditions	Min	Typ	Max	Units
V_{IH}	Input Logic High (EN, $\overline{\text{EN}}$)		1.2			V
V_{IL}	Input Logic Low (EN, $\overline{\text{EN}}$)				0.4	V
R_{I_PD}	Input Logic Pull-Down ($\overline{\text{EN}}$)			1		$\text{M}\Omega$
I_{I_LK}	Input Logic Leakage (EN)	$V_I = 5\text{V}$ $V_I = 28\text{V}$	-1 -1		1 1	μA μA

Switch Specifications

Symbol	Description	Conditions	Min	Typ	Max	Units	
R_{ON}	Switch On-Resistance ⁹	$V_{BUS} = 5\text{V}$		24	30	$\text{m}\Omega$	
		$V_{BUS} = 20\text{V}$		24	30		
		$V_{BUS} = 28\text{V}$		24	30		
	Switch On-Resistance ⁹ (KTS1897C/D in I_{SOURCE} Mode)	$V_{SYS} = 5\text{V}$			24	30	$\text{m}\Omega$
		$V_{SYS} = 20\text{V}$			24	30	
		$V_{SYS} = 28\text{V}$			24	30	
I_{BUS_OFF}	Switch Off-Leakage at V_{BUS}	Shutdown, $V_{BUS} = 5\text{V}$, $V_{SYS} = 0\text{V}$		1	3.5	μA	
		Shutdown, $V_{BUS} = 20\text{V}$, $V_{SYS} = 0\text{V}$		2	7		
		Shutdown, $V_{BUS} = 28\text{V}$, $V_{SYS} = 0\text{V}$		3	7.5		
I_{SYS_OFF}	Switch Off-Leakage at V_{SYS}	Shutdown, $V_{BUS} = 0\text{V}$, $V_{SYS} = 5\text{V}$		1		μA	
		Shutdown, $V_{BUS} = 0\text{V}$, $V_{SYS} = 20\text{V}$		2			
		Shutdown, $V_{BUS} = 0\text{V}$, $V_{SYS} = 28\text{V}$		3			

(continued next page)

8. Device is guaranteed to meet performance specifications over the -40°C to $+85^{\circ}\text{C}$ operating temperature range by design, characterization, and correlation with statistical process controls.

9. KTS1897A/B is tested with 1.3A output current, KTS1897C/D is tested with 240mA output current, both are at room temperature.

Electrical Characteristics (continued)¹⁰

Unless otherwise noted, the *Min* and *Max* specs are applied over the full operation range of $T_J = -40^{\circ}\text{C}$ to $+125^{\circ}\text{C}$ and $V_{\text{BUS}} = 3\text{V}$ to 33V or $V_{\text{SYS}} = 3\text{V}$ to 33V . Typical values are specified at $T_A = +25^{\circ}\text{C}$ with $V_{\text{BUS}} = 5\text{V}$ or $V_{\text{SYS}} = 5\text{V}$.

Soft-Start (SS) Specifications (see Figure 1)

Symbol	Description	Conditions	Min	Typ	Max	Units
t_{HICCUP}	Hiccup Retry Time after fault ^{11, 12}	After OVP/SCP/OTP is triggered		64		ms
t_{DEB}	Soft-Start Debounce Time ¹³	$V_{\text{BUS}} = 5\text{V}$		16		ms
		$V_{\text{SYS}} = 5\text{V}$ (KTS1897C/D in I_{SOURCE} Mode)		16		ms
t_{R}	Soft-Start Rising Slew-Rate Ramp Time ¹⁴	$V_{\text{BUS}} = 5\text{V}$	1	3	5	ms
		$V_{\text{BUS}} = 28\text{V}$	1	3	5	
		$V_{\text{SYS}} = 5\text{V}$ (KTS1897C/D in I_{SOURCE} Mode)	1	3	5	
$I_{\text{LIM_SS}}$	Soft-Start Current Limit	$V_{\text{BUS}} = 5\text{V}$		3.1		A
		$V_{\text{BUS}} = 28\text{V}$		1.7		
		$V_{\text{SYS}} = 5\text{V}$ (KTS1897C/D in I_{SOURCE} Mode)		3.6		
$t_{\text{LIM_SS}}$	Soft-Start Current Limit Done Time ¹¹	$V_{\text{BUS}} = 5\text{V}$ to 28V		16		ms
		$V_{\text{SYS}} = 5\text{V}$ to 28V (KTS1897C/D in I_{SOURCE} Mode)		16		
t_{DOFF}	Turn-Off Delay Time ^{11, 15}		0	1	10	μs

(continued next page)

10. Device is guaranteed to meet performance specifications over the -40°C to $+85^{\circ}\text{C}$ operating temperature range by design, characterization and correlation with statistical process controls.

11. Guaranteed by design, characterization and statistical process control methods; not production tested.

12. t_{HICCUP} is time from protection triggers until the start of Soft-Start Debounce Time.

13. t_{DEB} is time from enabled logic and valid supply voltage until the output voltage begins to rise.

14. t_{R} is time from the output voltage reaches 10% until the output voltage reaches 90% of the input voltage.

15. t_{DOFF} is time from disable logic until the output voltage begins to fall.

Electrical Characteristics (continued)¹⁶

Unless otherwise noted, the *Min* and *Max* specs are applied over the full operation range of $T_J = -40^{\circ}\text{C}$ to $+125^{\circ}\text{C}$ and $V_{\text{BUS}} = 3\text{V}$ to 33V or $V_{\text{SYS}} = 3\text{V}$ to 33V . Typical values are specified at $T_A = +25^{\circ}\text{C}$ with $V_{\text{BUS}} = 5\text{V}$ or $V_{\text{SYS}} = 5\text{V}$.

Over-Voltage Protection (OVP) Specifications

Symbol	Description	Conditions	Min	Typ	Max	Units
V_{OVP}	Internally Fixed Over-Voltage Protection	input voltage rising OVP threshold	32	33	34	V
		Hysteresis, $V_{\text{OVLO}} = 0\text{V}$		900		mV
t_{OVP}	OVP Response Time ^{11, 17}	input voltage $> V_{\text{OVP}}$, $R_L = 100\Omega$, $C_{\text{OUT}} = 0\mu\text{F}$, $V_{\text{OVLO}} = 0\text{V}$		100		ns
$t_{\text{OVP_REC}}$	OVP Recovery Time ^{11, 18}		$t_{\text{HICCUP}} + t_{\text{DEB}} + t_{\text{R}}$			ms
V_{OVLO}	Externally Adjustable Over-Voltage Lockout	V_{OVLO} enable threshold	0.12	0.175	0.23	V
		V_{OVLO} rising OVP threshold	1.18	1.23	1.28	V
		Hysteresis		25		mV
V_{OVLOS}	Adjustable Over-Voltage Lockout of OVLOS Pin	V_{OVLOS} rising OVP threshold	1.18	1.23	1.28	V
		Hysteresis		25		mV
t_{OVLO}	OVLO Response Time ^{11, 19}	$R_L = 100\Omega$, $C_{\text{OUT}} = 0\mu\text{F}$		300		ns
$t_{\text{OVLO_REC}}$	OVLO Recovery Time ¹¹		$t_{\text{HICCUP}} + t_{\text{DEB}} + t_{\text{R}}$			ms

Reverse-Current Protection (RCP) Specifications (KTS1897A/B only)

Symbol	Description	Conditions	Min	Typ	Max	Units
V_{RCP}	RCP Droop Regulation Voltage	$V_{\text{RCP}} = V_{\text{BUS}} - V_{\text{SYS}}$, $I_{\text{SYS}} = 100\text{mA}$	10	20	30	mV
$t_{\text{RCP_REC}}$	RCP Fast Recovery Time ^{20, 21}			15		μs

Over-Current Protection (OCP) Specifications

Symbol	Description	Conditions	Min	Typ	Max	Units
I_{OCP}	Over-Current Protection (OCP) Threshold ²¹		15	20		A
t_{OCP}	OCP Response Time ^{21, 22}			150		ns
$t_{\text{OCP_REC}}$	OCP Recovery Time ²¹		$t_{\text{DEB}} + t_{\text{R}}$			ms
$t_{\text{SCP_REC}}$	SCP Recovery Time ²¹		$t_{\text{HICCUP}} + t_{\text{DEB}} + t_{\text{R}}$			ms

Over-Temperature Protection (OTP) Specifications

Symbol	Description	Conditions	Min	Typ	Max	Units
t_{OTP}	IC Junction Over-Temperature Protection ²¹	T_J rising threshold		145		$^{\circ}\text{C}$
		Hysteresis		20		$^{\circ}\text{C}$
$t_{\text{OTP_REC}}$	OTP Recovery Time ²¹		$t_{\text{HICCUP}} + t_{\text{DEB}} + t_{\text{R}}$			ms

16. Device is guaranteed to meet performance specifications over the -40°C to $+85^{\circ}\text{C}$ operating temperature range by design, characterization and correlation with statistical process controls.

17. t_{OVP} is time from when the input voltage $> V_{\text{OVP}}$ until the output voltage stops rising.

18. $t_{\text{OVP_REC}}$ is time from when the input voltage $< V_{\text{OVP}}$ until the output voltage reaches 90% of input voltage.

19. t_{OVLO} is time from V_{OVLO} rises above its OVP threshold until the output voltage stops rising.

20. $t_{\text{RCP_REC}}$ is time from $V_{\text{BUS}} = V_{\text{SYS}} - V_{\text{RCP}}$ until switch turns back on. Before measuring, first raise $V_{\text{SYS}} \gg V_{\text{BUS}} + 270\text{mV}$.

21. Guaranteed by design, characterization and statistical process control methods; not production tested.

22. t_{OCP} is time from when the switch current $> I_{\text{OCP}}$ until switch turns off.

Timing Diagrams

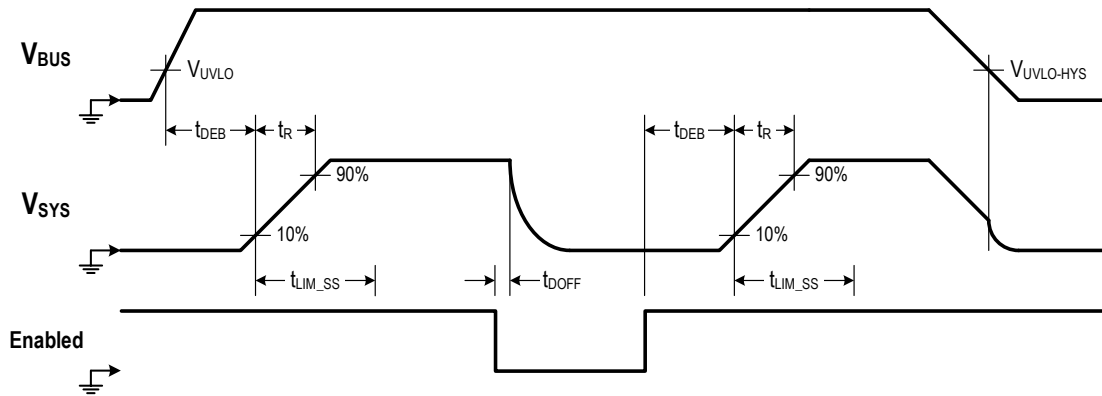

Figure 1. UVLO, Soft-Start and Turn-Off Timing Diagram

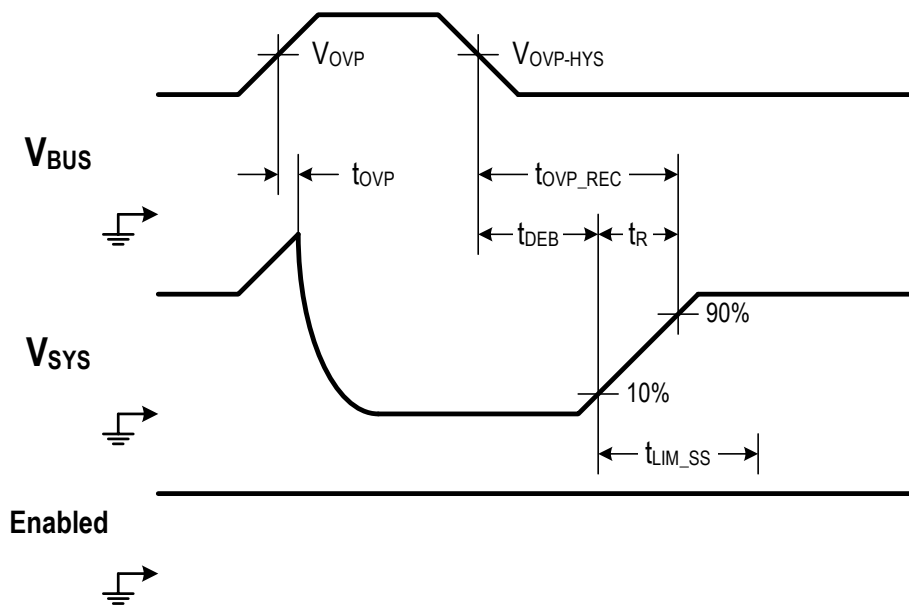

Figure 2. OVP Timing Diagram(OVLO pin)

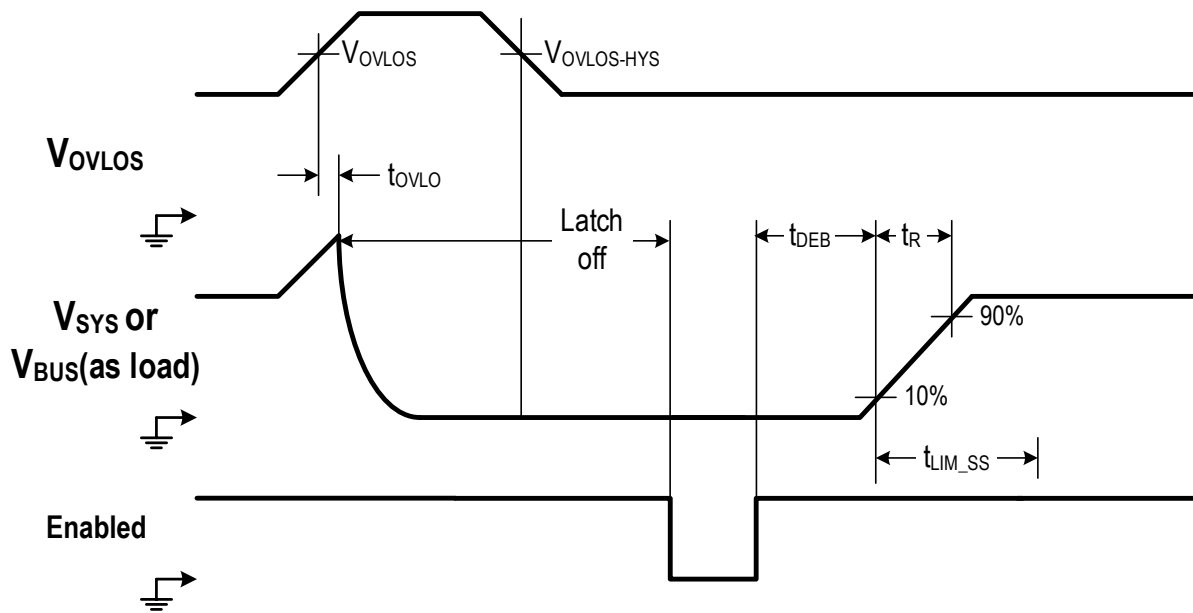

Figure 3. OVP Timing Diagram (OVLOS pin)

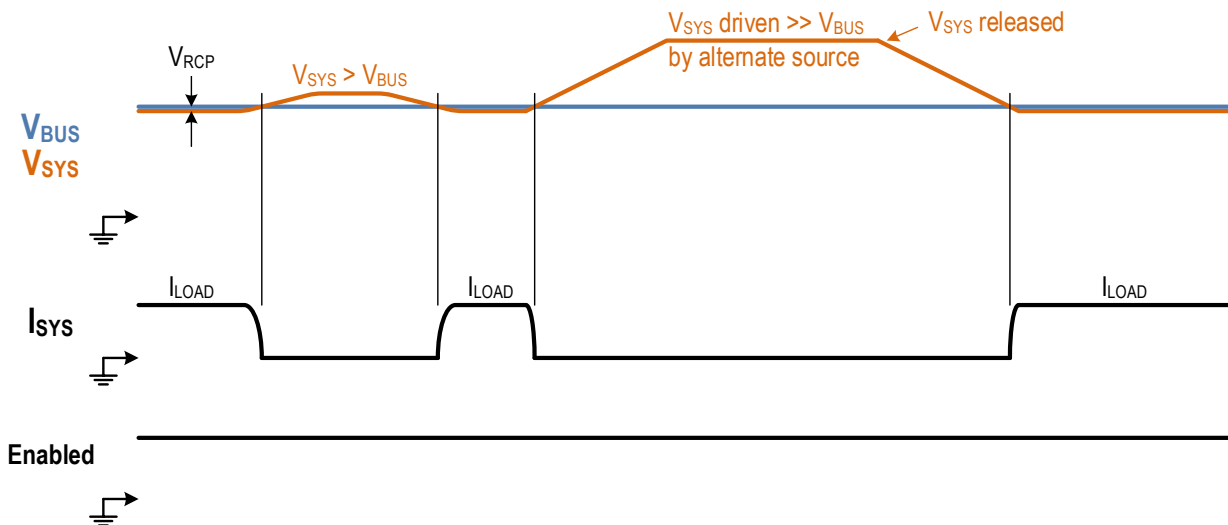

Figure 4. "Ideal Diode" RCP Timing Diagram (KTS1897A/B only)

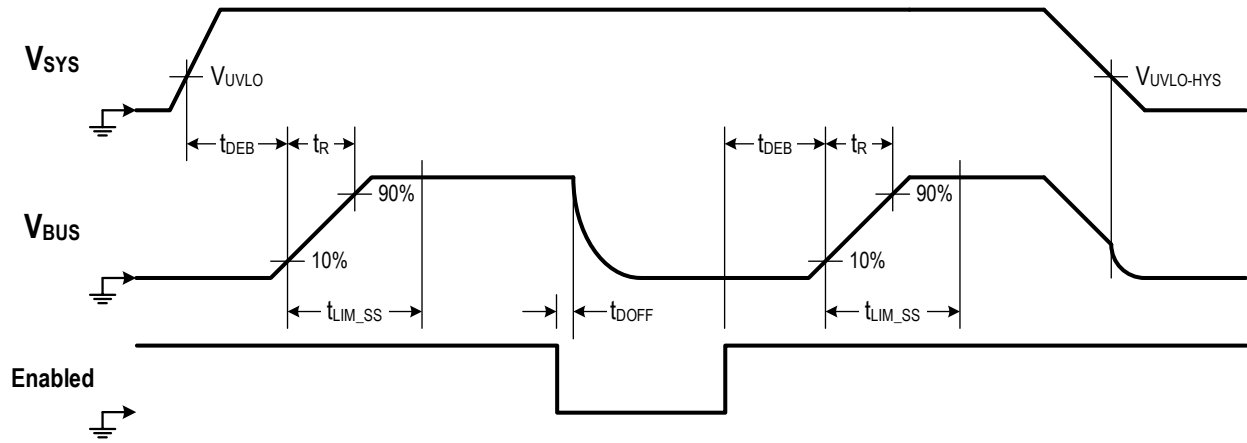
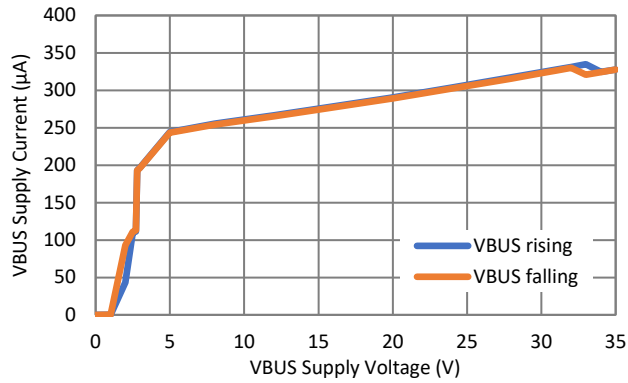

Figure 7. UVLO, Soft-Start and Turn-Off Timing Diagram in I_{SOURCE} Mode (KTS1897C/D Only)

Typical Characteristics

$C_{VBUS} = 10\mu F$, $C_{V_{SYS}} = 20\mu F$, and $T_A = +25^\circ C$ unless otherwise noted.

VBUS Supply Current Vs. Supply Voltage
(No Load, EN = High)



VBUS Supply Current Vs. Supply Voltage
(No Load, EN = Low)

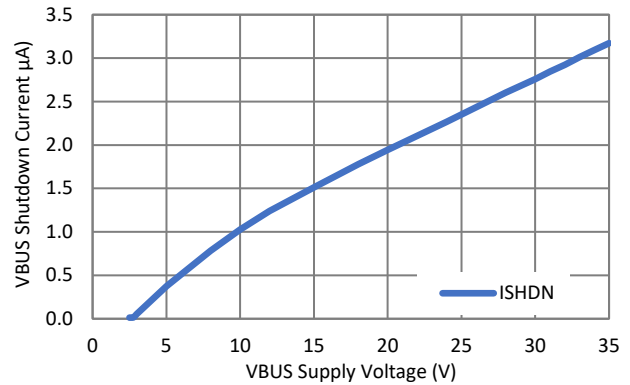

On Resistance Vs. Load Current
(KTS1897A/B, Uni-directional with RCP)

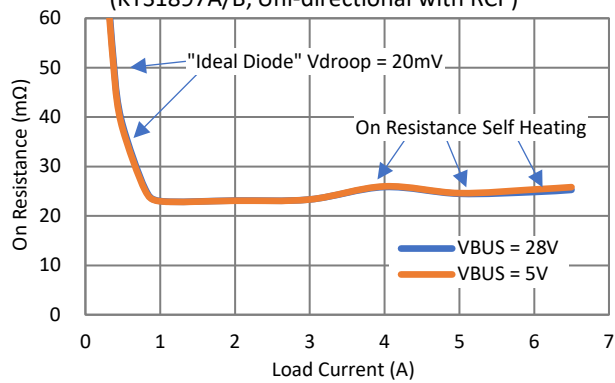

"Ideal Diode" Vdroop Vs. Load Current
(KTS1897A/B, Uni-directional with RCP)

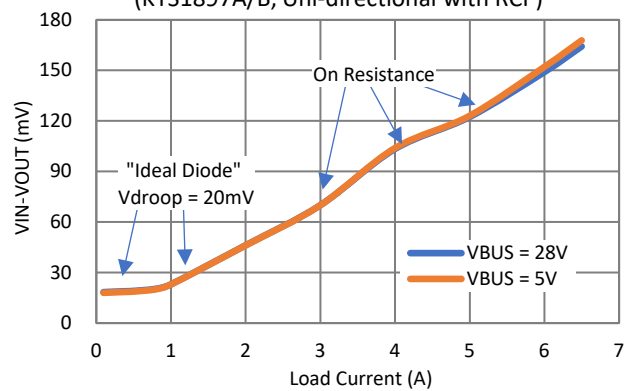

On Resistance Vs. Load Current
(KTS1897C/D Bi-directional in Isink Mode)

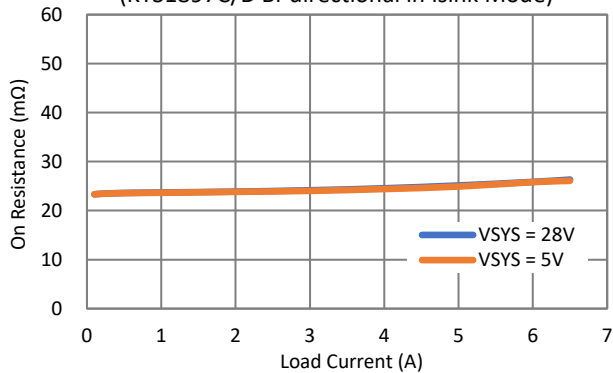

On Resistance Vs. Load Current
(KTS1897C/D Bi-directional in Isource Mode)

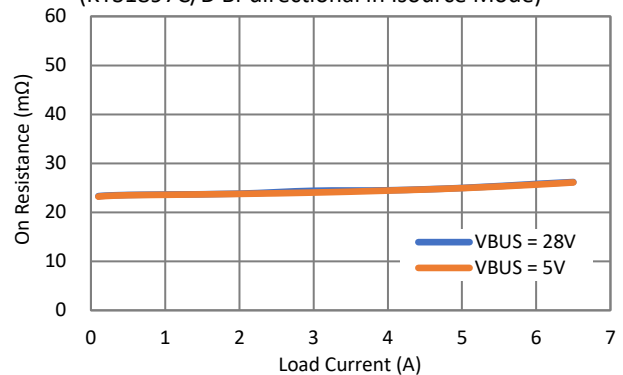

(continued next page)

Typical Characteristics (continued)

$C_{VBUS} = 10\mu\text{F}$, $C_{V_{SYS}} = 20\mu\text{F}$, and $T_A = +25^\circ\text{C}$ unless otherwise noted.

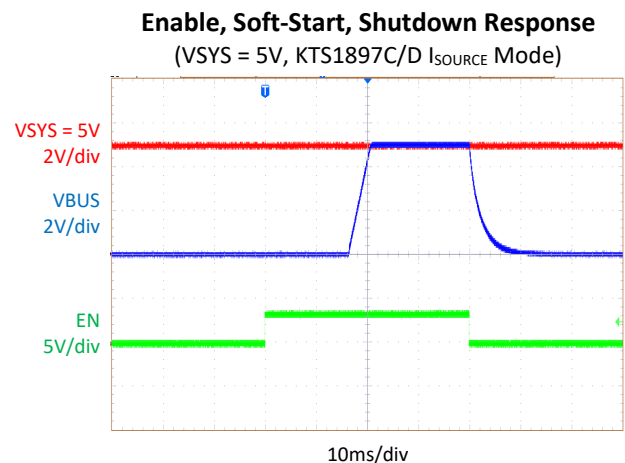
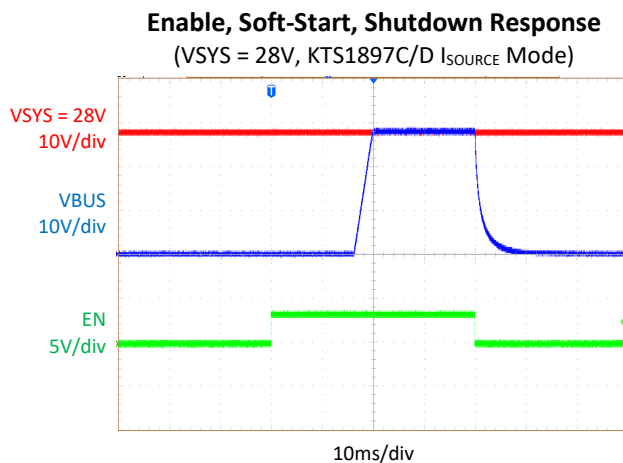
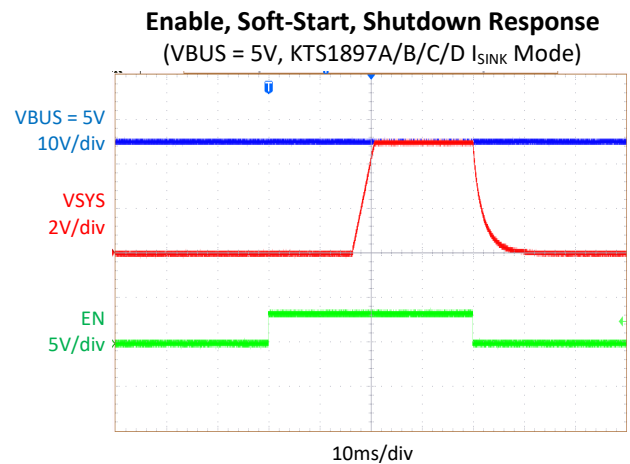
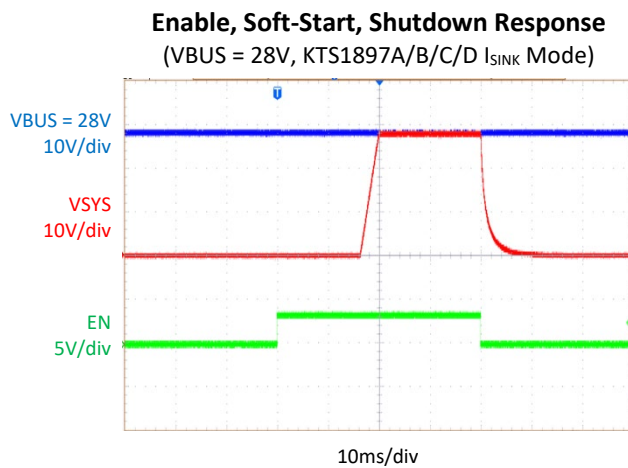
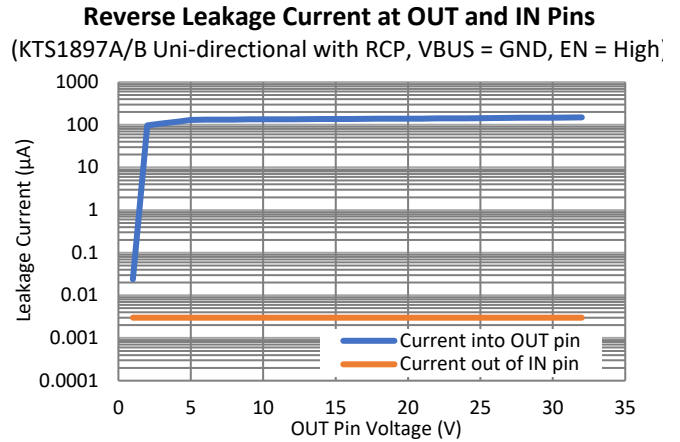
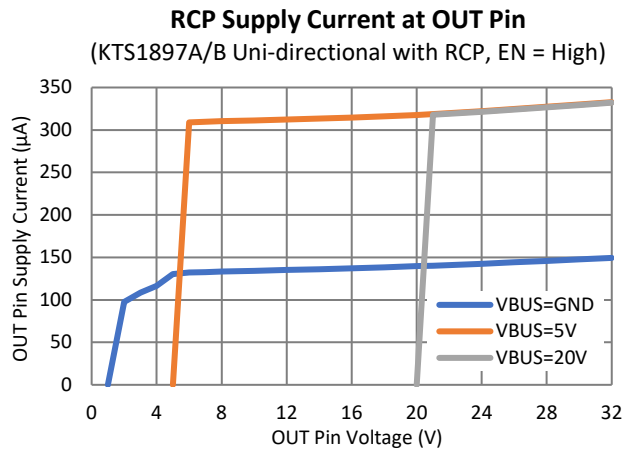

(continued next page)

Typical Characteristics (continued)

$C_{VBUS} = 10\mu\text{F}$, $C_{V_{SYS}} = 20\mu\text{F}$, and $T_A = +25^\circ\text{C}$ unless otherwise noted.

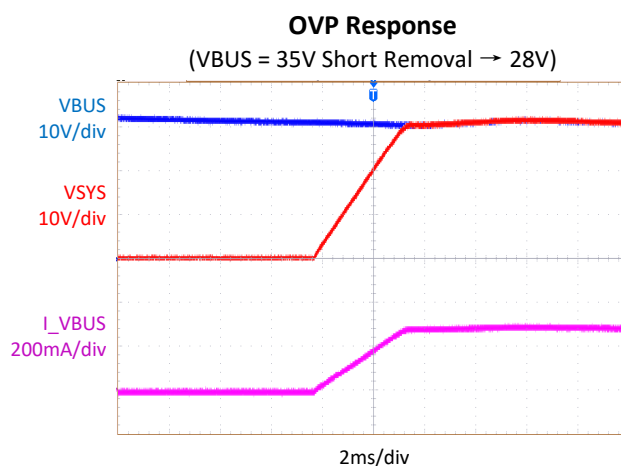
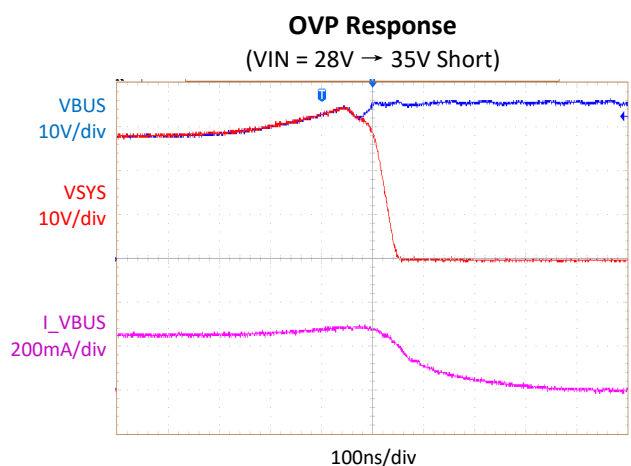
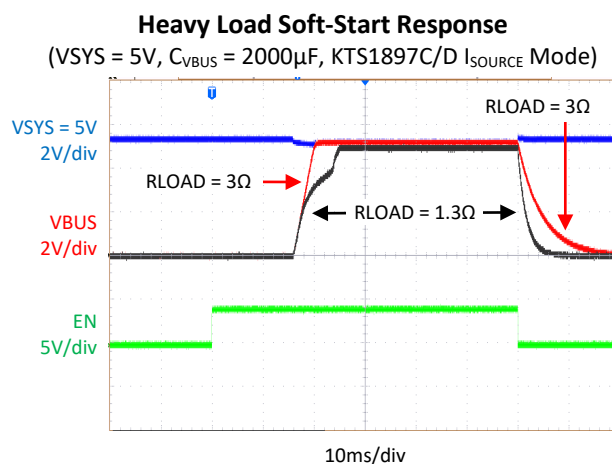
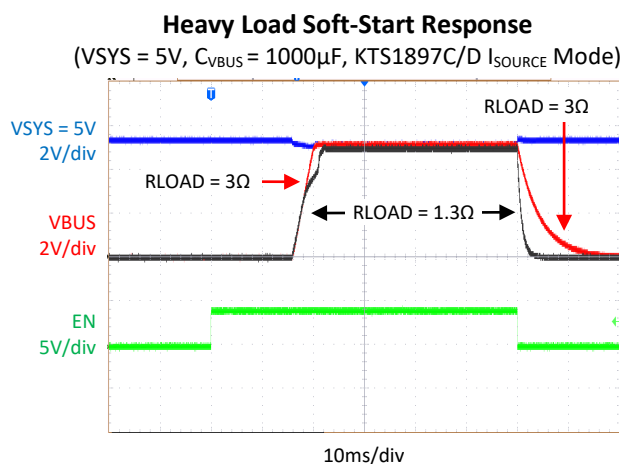
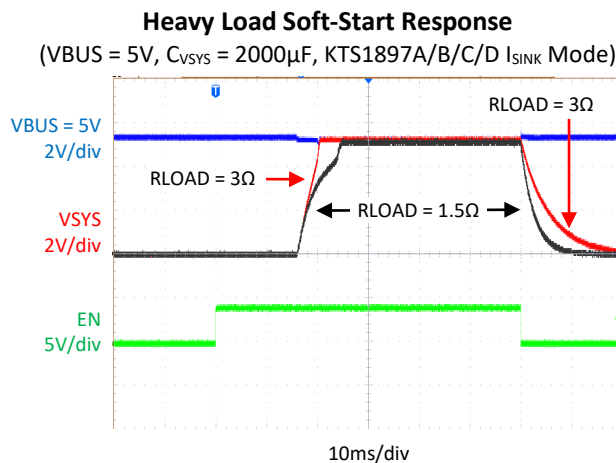
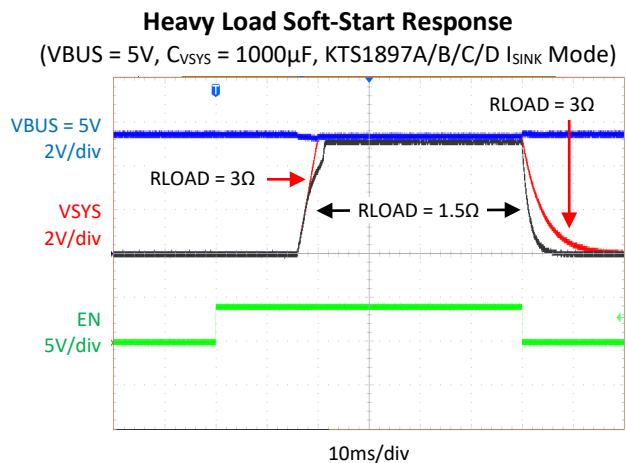

(continued next page)

Typical Characteristics (continued)

$C_{VBUS} = 10\mu\text{F}$, $C_{V_{SYS}} = 20\mu\text{F}$, and $T_A = +25^\circ\text{C}$ unless otherwise noted.

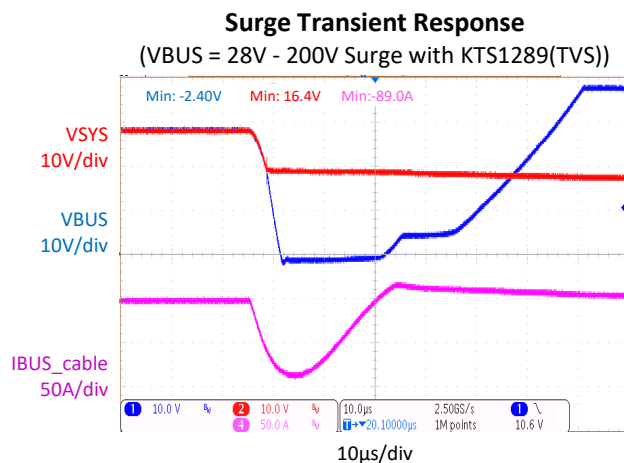
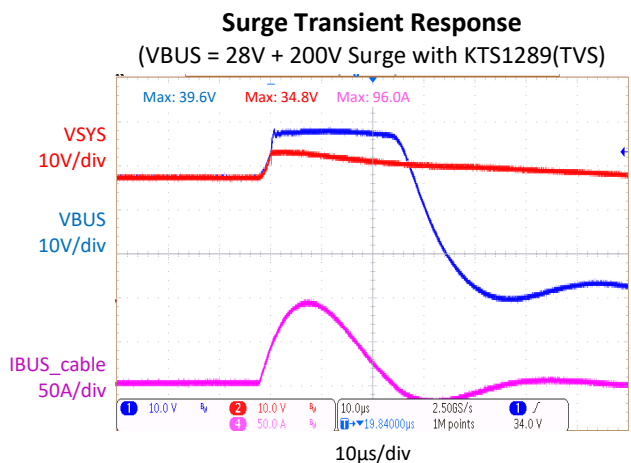
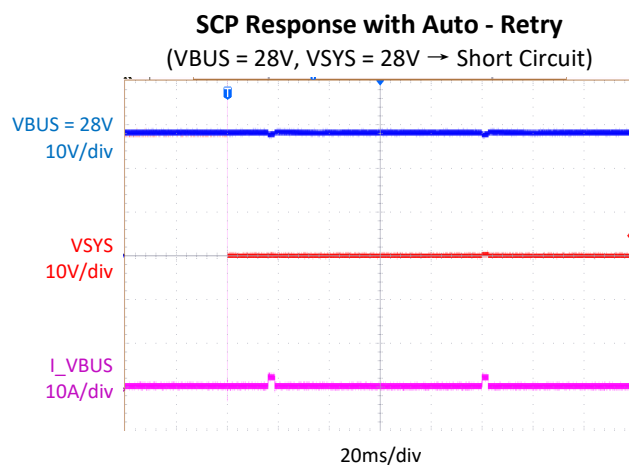
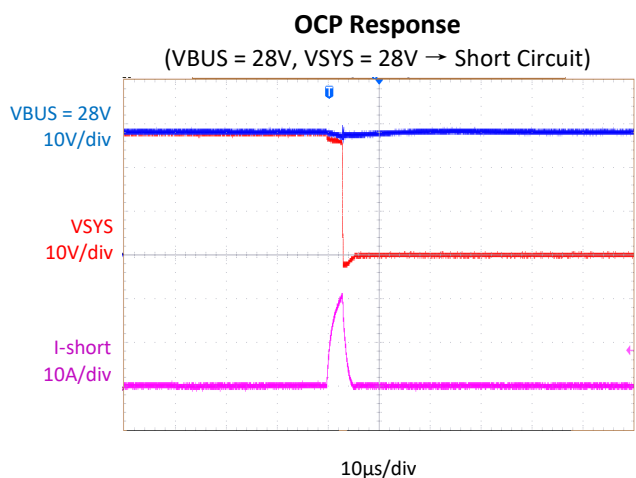
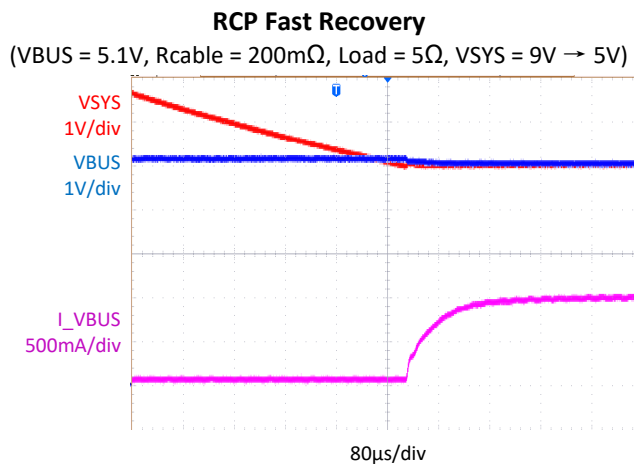
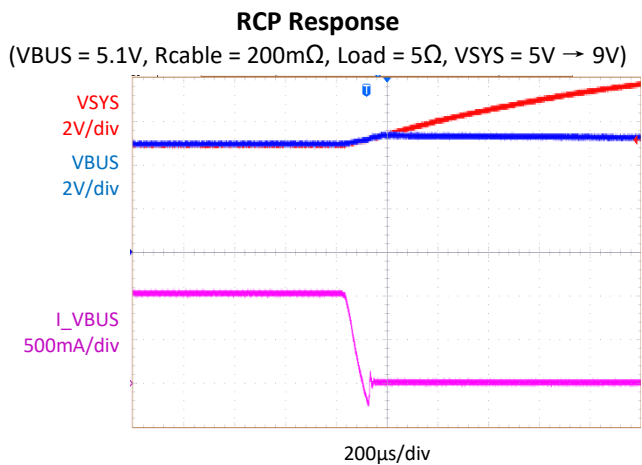

Functional Block Diagram

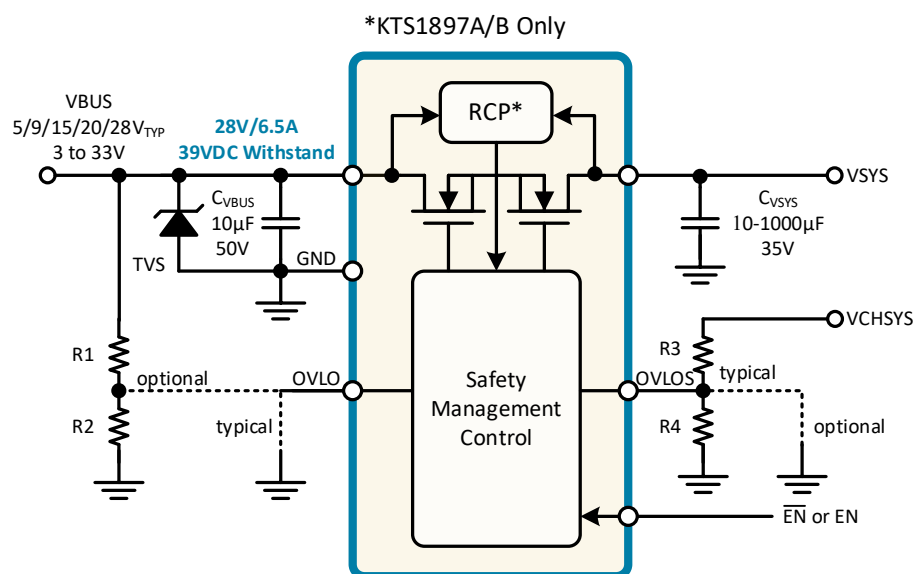

Figure 8. Functional Block Diagram

Functional Description

The KTS1897 is a slew-rate controlled, 24mΩ (typ) low resistance MOSFET switch intended to be inserted between a power source and a load to isolate and protect against abnormal voltage and current conditions. Featuring slew-rate controlled soft-start and soft-start current limit to prevent excessive large inrush current, the KTS1897 also features several additional protection functions. These include input over-voltage protection, “ideal diode” reverse-current protection with fast recovery (KTS1897A/B only), output short-circuit protection, over-current protection, and over-temperature protection.

Operating from a wide input voltage range of 3V to 33V, the KTS1897A/B is optimized for USB Type-C Power Delivery (PD) current-sink applications up to 28V extended power range (EPR) that require essential protection and enhanced system reliability. While in the OFF state, the KTS1897 blocks voltages of up to 39V on the VBUS pin and 35V on the VSYS pin and prevents current flow. While in the ON state, the KTS1897A/B withstands voltages of up to 39V on the VBUS pin and 35V on the VSYS pin, passes valid input voltages and current from VBUS to VSYS, and blocks reverse current from VSYS to VBUS. Due to the ideal-diode behavior, two or more KTS1897A/B parts can be used in parallel to support systems that may be charged or powered from multiple ports.

KTS1897A/B has automatic reverse-current protection (RCP) feature which acts as an “ideal diode” with fast recovery and isolates VBUS when charging or powering the system via another port. KTS1897C/D supports bi-directional mode when enabled so it is optimized for USB Type-C Power Delivery (PD) current-sink and/or current-source applications.

Shutdown and Enable

The KTS1897A/C has \overline{EN} active-low input logic with internal 1MΩ pull-down resistor. The KTS1897B/D has EN active-high input logic. When disabled, the main power MOSFETs are turned off, and the device enters low-

power shutdown mode. When enabled, all additional protection circuits are active, and if no fault condition exists, the main power MOSFETs are turned ON.

Under-Voltage Lockout (UVLO)

The UVLO function keeps the switches in the OFF state when the input voltage is below the UVLO threshold, regardless of the enable logic level. When the input voltage is above the UVLO threshold and the device is enabled via logic input and there are no fault conditions, the switches are enabled to the ON state.

Soft-Start (SS)

The internal soft-start function allows the KTS1897 to charge a total output capacitance of 1000μF to 5V without excessive in-rush current. Soft-start controls the output voltage slew-rate ramp time. Use the below formula to calculate the current required to charge C_{OUT} :

$$I_{IN_SS} = I_{LOAD} + C_{OUT} \left(\frac{V_{IN}}{t_R} \right)$$

where $t_R = 3ms$. In either case, the soft-start time is somewhat fast to reduce power dissipation in the KTS1897 during soft-start.

Note that in addition to the soft-start voltage ramp, a simultaneous soft-start current limit of 2.9A prevents excessive heat when starting into an output short-circuit condition or a large total output capacitance. This current limit turns off after 16ms (lasting several milliseconds longer than the soft-start voltage ramp). After an additional 13ms delay, if the output voltage is near the input voltage. See the *Heavy Load Soft-Start Response* in the *Typical Characteristics* section.

Over-Voltage Protection (OVP) of OVLO pin

When $EN = H$ or $\overline{EN} = L$, the switch is logically enabled. However, if the input voltage exceeds the internally-set V_{OVP} , the power switch is disabled due to an OVP fault. Once the input voltage drops below V_{OVP} , no other fault is detected, and $EN = H$ or $\overline{EN} = L$, the power switch is automatically re-enabled after the hiccup time expires via the soft-start debounce and ramp times.

The OVLO pin is used to adjust the over-voltage threshold externally. The default internal over-voltage threshold is 33V when the OVLO pin is tied to GND. Biasing the OVLO pin with a resistive voltage divider adjusts the over-voltage threshold from 4V to 33V as in the below formula:

$$V_{OVP} = V_{OVLO} \left(1 + \frac{R1}{R2} \right)$$

where $V_{OVLO} = 1.23V$. Connect R1 from VBUS to OVLO. Connect R2 from OVLO to ground. See Figure 8. For KTS1897C/D, in some applications, notably I_{SOURCE} mode only use, optionally tie R1 to VSYS (rather than VBUS) if over-voltage protection of VSYS is of value.

Over-Voltage Protection (OVP) and latch off of OVLOS pin

When $EN = H$ or $\overline{EN} = L$, the switch is logically enabled. However, if the system voltage after the charger exceeds the over-voltage threshold V_{OVPS} , the power switch is disabled due to an OVP fault and it will **latch off**. When KTS1897 is latched off, the EN input pin when toggled (from High to Low to High for $EN = H$, from Low to High to Low for $\overline{EN} = L$) allows to restart the device after OVLOS OVP fault latch. See Figure 3.

The OVLOS pin is used to adjust the over-voltage threshold for the system power rail after the charger. Biasing the OVLOS pin with a resistive voltage divider adjusts the over-voltage threshold from 4V to 28V as in the below formula:

$$V_{OVPS} = V_{OVLOS} \left(1 + \frac{R3}{R4} \right)$$

where $V_{OVLOS} = 1.23V$. Connect R3 from VCHSYS to OVLOS. Connect R4 from OVLOS to ground. See Figure 8. Connect OVLOS pin to GND if it is not used.

Over-Current Protection (OCP)

The KTS1897 includes output over-current protection (OCP) at 20A that protects the IC from damage when an over-current or short-circuit event suddenly appears. The OCP circuit disables the power switch, so the current becomes zero. After an OCP event, if no other fault is detected, and $EN = H$ or $\overline{EN} = L$, the power switch is re-enabled after the soft-start debounce and ramp times.

Short-Circuit Protection (SCP)

The KTS1897 includes output short-circuit protection (SCP). If an SCP event occurs while the KTS1897 is already enabled and working, OCP is the first line of defense and responds very quickly. In this case, the current from C_{IN} through the switch to C_{OUT} increases very rapidly. For SCP events that do not reach OCP, if the output voltage droops significantly below the input voltage, it is also detected as a soft-short event. In case of auto-retry or simply starting into a pre-existing SCP condition, the KTS1897 furthermore includes SCP detection during soft-start if the output voltage is not ramping up. The KTS1897 remains undamaged during continuous SCP events. The hiccup time reduces the average power dissipation during extended SCP conditions.

“Ideal Diode” Reverse-Current Protection (RCP, KTS1897A/B only)

The KTS1897 offers reverse-current protection regardless of the enable logic level. When disabled, all current flow is blocked. When enabled, the RCP acts as a voltage droop regulator. Once the voltage on V_{SYS} is higher than V_{BUS} minus 20mV, the RCP circuit reduces the MOSFET gate drive to try and maintain the regulated 20mV droop, thereby acting as an “ideal diode” with $V_f = 20mV$. See Figure 9. This control method blocks all reverse current within the RCP control loop bandwidth. The RCP circuit makes it possible to connect two or more USB charging ports to a single charger input in a “diode-OR” configuration with autonomous reverse-current blocking.

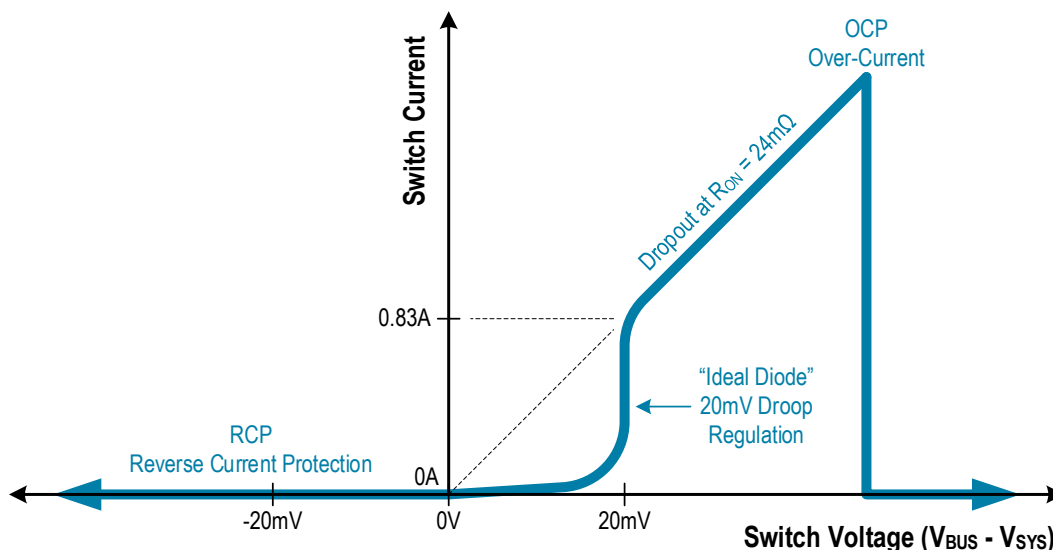

Figure 9. “Ideal Diode” Reverse-Current Protection V-I Curve (KTS1897A/B only)

Over-Temperature Protection (OTP)

When device junction temperature exceeds 145°C, the OTP circuit disables the power switch. Once the device junction temperature decreases below 125°C, if no other fault is detected, and $EN = H$ or $\overline{EN} = L$, the power switch is re-enabled after the hiccup time expires via the soft-start debounce and ramp times.

Auto-Retry

For all fault conditions **except OVLOS fault** that cause the switch to open, the KTS1897 will auto-retry via the soft-start debounce and ramp time. If any fault or the same fault is detected again, the switch will open again, and auto-retry will repeat. This continues until the fault is removed (normal operation) or $EN = L$ or $\overline{EN} = H$ (shutdown) or the input voltage is removed (UVLO). The hiccup timer extends the delay between auto-retry events, but only after the first retry.

Applications Information

VBUS Capacitor C_{VBUS} Selection

For most applications, connect a 1 μ F to 10 μ F ceramic capacitor as close as possible to the device from VBUS to GND to minimize the effect of parasitic trace inductance. A 50V rated capacitor with X5R or better dielectric is recommended. For optimal surge and ESD performance, 10 μ F is preferred.

VSYS Capacitor C_{VSYS} Selection

For most applications, connect from 10 μ F to 1000 μ F total capacitance to the output. Typical applications use 30 μ F to 100 μ F as needed for system load-transients. At minimum, connect a 10 μ F ceramic capacitor as close as possible to the device from VSYS to GND to minimize the effect of parasitic trace inductance. 35V or 50V rated capacitors with X5R or better dielectric are recommended. Lower voltage ratings may be acceptable when using the OVLO pin to set a lower over-voltage protection threshold.

TVS Selection

In order to prevent any unexpected ESD/Surge event damaging the OVP chip, a suitable uni-directional TVS must be carefully selected and used between VBUS pin and GND pin. First of all, the working voltage of TVS should be determined. A TVS with $V_{RWM} \geq 33V$ can be selected for 28V charging port. Secondly, it is necessary to meet the requirement of surge protection capability. According to IEC61000-4-5 8/20 μ s surge standard, if customer wants to select a TVS with the surge voltage rating of 100V, the TVS should meet the requirement of $I_{PP} \geq (100V - 40V) / 2\Omega = 30A$. When selecting the model of TVS, the maximum clamping voltage at desired I_{PP} of the TVS should be below **45V**. KTS1289 is an active flat-clamp TVS which can meet this requirement perfectly (See Surge Transient Response waveform in page 15). Too high clamping voltage of TVS will cause damage to the OVP chip.

Recommended PCB Layout

Good PCB thermal design is required to support heavy load currents. The KTS1897 EVB is designed with similar layout as Figure 10. Recommended PCB Layout, but it extends the fill area for the VBUS, VSYS, and GND copper planes to about 4 square inches total area for increased thermal performance. Due to the number of bumps on VBUS and VSYS, these two planes are especially important and should not be ignored. Adding back-side and/or buried-layer fill area with thermal vias also helps significantly.

Other than thermal concerns, the PCB layout for the KTS1897 is quite simple. Place the TVS, input and output capacitors near the IC. Connect the TVS, capacitor ground terminals together and to the GND pins using the top-side copper layer. Route the control signals on buried layers. For internally set 33V OVP, directly connect the OVLO pin to the GND pins (as shown in Figure 10).

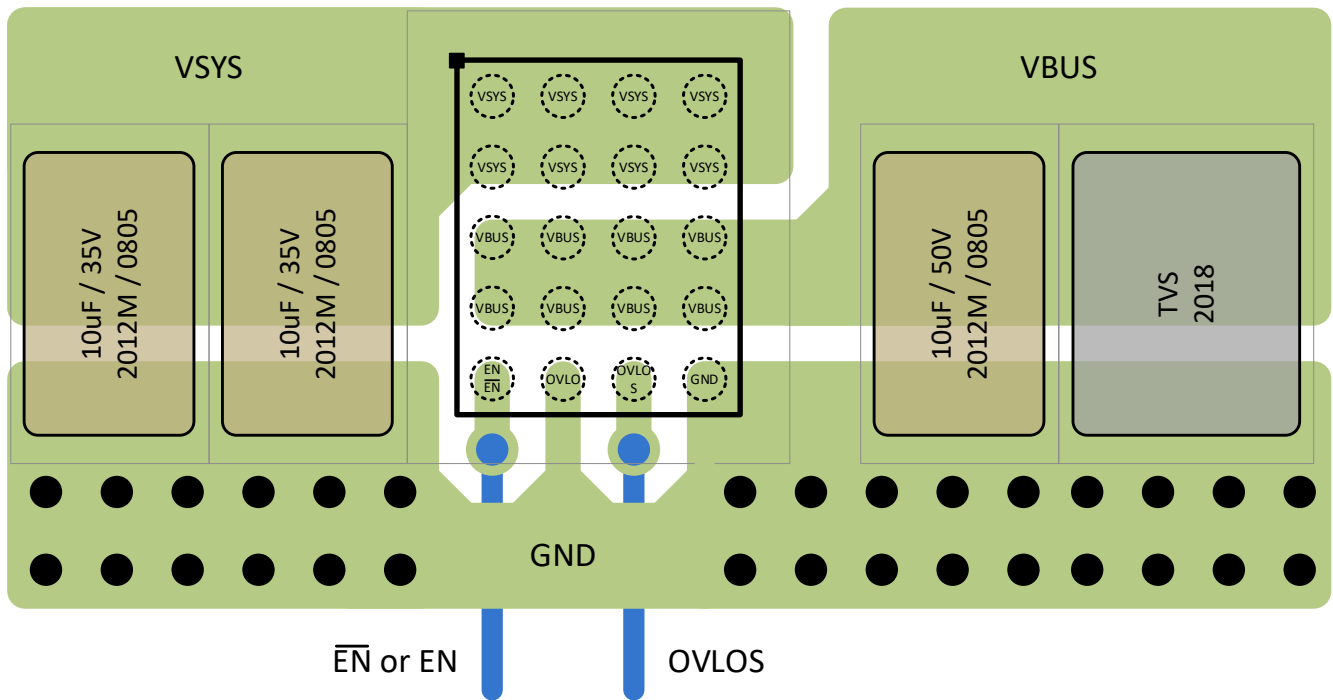
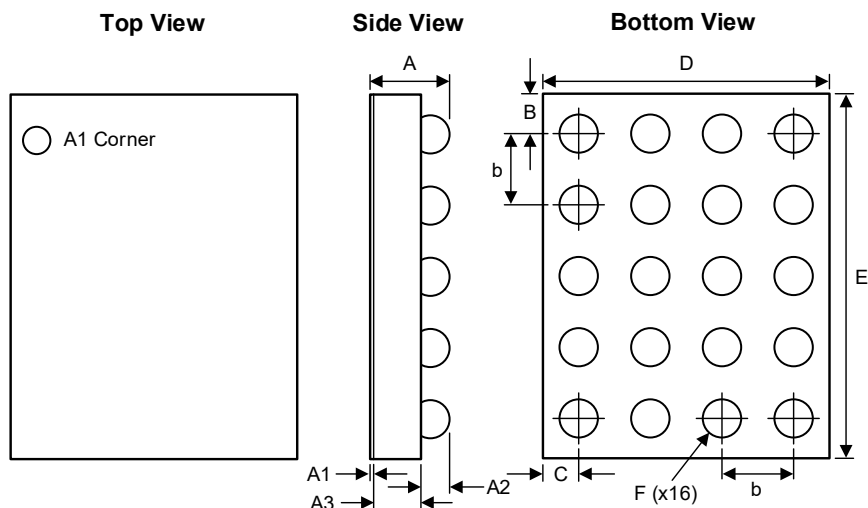

Figure 10. Recommended PCB Layout

Packaging Information

WLCSP54-20 (2.000mm x 2.560mm x 0.555mm)



Dimension	mm		
	Min.	Typ.	Max.
A	0.518	0.555	0.592
A1	0.023	0.025	0.027
A2	0.180	0.200	0.220
A3	0.315	0.330	0.345
B	0.280 REF.		
b	0.500 REF.		
C	0.250 REF.		
D	1.950	2.000	2.050
E	2.510	2.560	2.610
F	0.252	0.280	0.308
S1	1.50 REF.		
S2	2.00 REF.		
S3	–	0.25	–
S4	–	0.35	–

Recommended Footprint

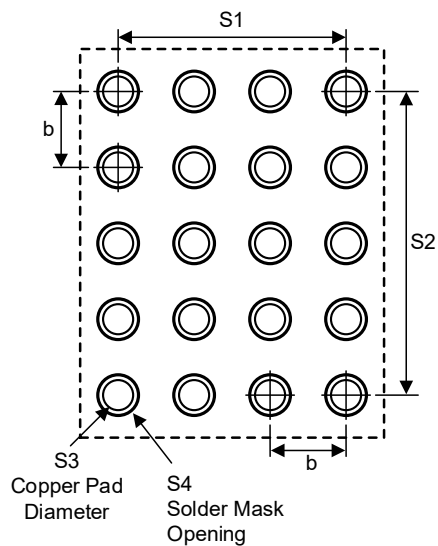

Packing Material Information

Reel Dimensions

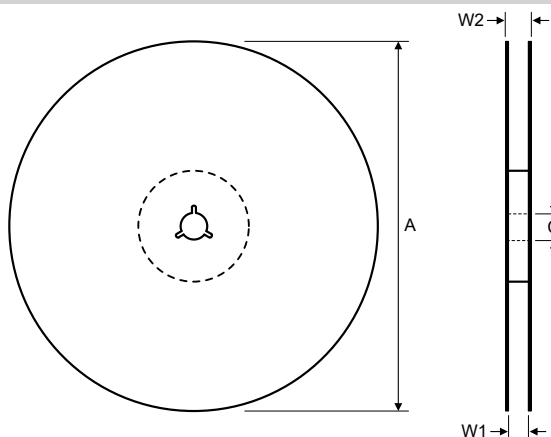

Dimension	mm		
	Min.	Typ.	Max.
A	160	180	200
C	12.8	13.0	13.5
W1	8.4	8.4	9.9
W2	10.4	12.4	14.4

KS-180x54-B Reel

Carrier Tape Dimensions

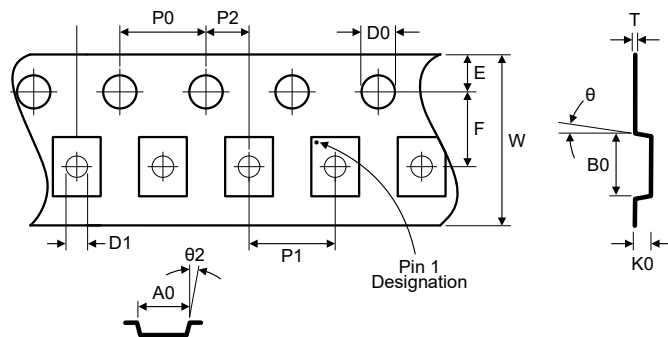

Dimension	mm		
	Min.	Typ.	Max.
A0	2.17	2.22	2.27
B0	2.67	2.72	2.77
K0	0.72	0.77	0.82
P0	3.90	4.00	4.10
P1	3.90	4.00	4.10
P2	1.95	2.00	2.05
D0	1.50	1.55	1.60
D1	1.00	—	—
E	1.65	1.75	1.85
F	3.45	3.50	3.55
10P0	39.8	40.0	40.2
W	7.90	8.00	8.30
T	0.15	0.20	0.25
θ	0°		5°
$\theta 2$	0°		5°

625-41-0131

Cover Tape Dimensions

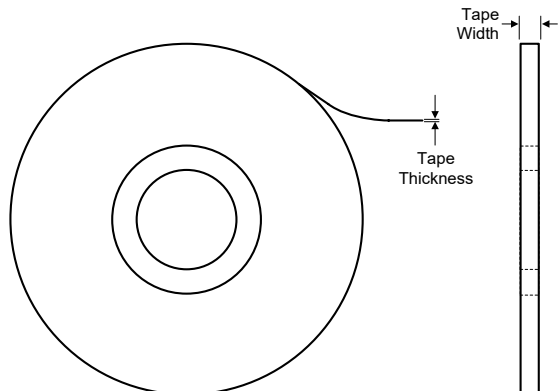

Dimensions	Dimension	mm		
		Min.	Typ.	Max.
8mm	Tape Thickness	0.045	0.05	0.055
	Tape Width	5.2	5.3	5.4

BI-16-05-21 cover tape

Kinetic Technologies cannot assume responsibility for use of any circuitry other than circuitry entirely embodied in a Kinetic Technologies product. No intellectual property or circuit patent licenses are implied. Kinetic Technologies reserves the right to change the circuitry and specifications without notice at any time.