

Automotive Load Switch with OVP and RB Protection

Features

- Wide input operating range from 6V to +24V with protection up to 40V DC Input
- Low resistance MOSFET Switch typ. 41mΩ
- Reverse Battery Protection to -28V
- Fixed over-voltage protection
 - Fixed: 27V ± 0.8V or 20.3V ± 0.8V
- Fast OVP response time typ. 500ns
- Continuous output current up to 6A
- Over-temperature Protection with Auto-Retry
- Open drain fault flag
- Shutdown pin with low shutdown current
- Battery detection output
- Input ESD protection to IEC61000-4-2 (Level 4)
 - Contact: ±8kV
 - Air: ±15kV
 - Other pins HBM: ±2kV to AEC Q100-002
- AEC-Q100 Qualified
- Meets automotive ISO7637 transient requirements with suitable external TVS diodes
- Pb-free TDFN44-12 package
- -40°C to +125°C operating temperature range

Applications

- Automotive Load Switching
- Reverse Power Supply Protection
- Telecom/Server/Networking System
- Industrial and Medical Systems
- Portable Instrumentation

Brief Description

The KTS1640Q and KTS1641Q are low-resistance, electronically controlled load switches, with enhanced protection features, used to protect loads from abnormal power supply or load problems. Operating from a wide input supply voltage of between 6V and 40V, the KTS1640Q and KTS1640Q protect the system from reverse input supplies down to -28V.

Integrating two N-Channel MOSFETs, the device includes fixed over-voltage protection of 27V (KTS1640Q) or 20.3V (KTS1641Q) along with over-temperature protection with auto-retry. Following an over-voltage condition only, KTS1640Q and KTS1640Q will automatically resume operation, when the over-voltage condition is removed.

An ENABLE pin allows the MOSFET switch to be enabled or disabled, placing the device in a low current shutdown mode. System monitoring is provided by a fault FLAG.

To inform the system that the battery or power supply is connected, BDET mirrors the input voltage less the drop across the reverse battery protection MOSFET and sources up to a maximum of 500mA

Further protection includes over-temperature shutdown and the input pin is fully ESD protected to comply with the IEC61000-4-2 (Level 4) specification.

The KTS1640Q and KTS1641Q are packaged in an advanced, fully green compliant, TDFN44-12 package.

Typical Application

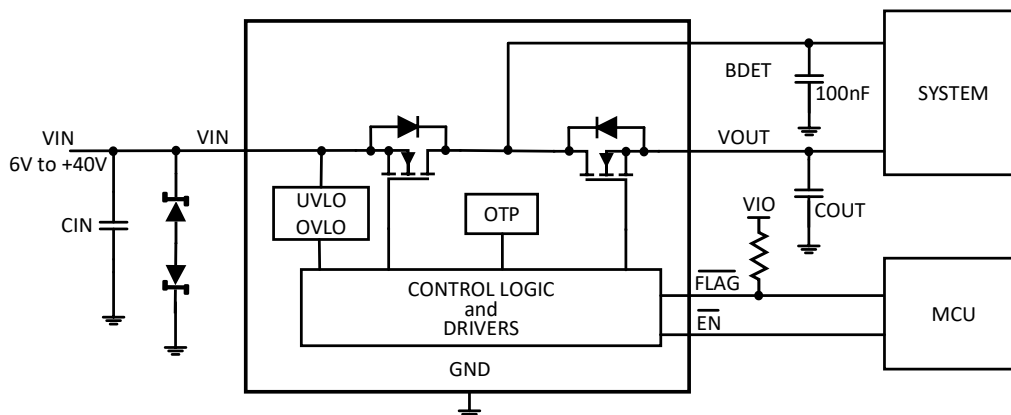

Pin Descriptions

Pin #	Name	Function		
1, 2, 3, 4	VIN	Input to the power switch and device supply. The VIN pins must be decoupled to GND via a minimum 1µF ceramic capacitor. To be compliant to the ISO7326 Automotive Transient specification, this pin should also be protected by two suitable external TVS diodes.		
5	$\overline{\text{EN}}$	Active LOW enable pin. Connect to GND to turn the power switch ON.		
6	GND	Ground		
7	BDET	Battery Detection, and supply. Should be decoupled by a 100nF capacitor to GND	$\overline{\text{EN}}$ = HIGH	BDET = VIN - 0.7V
			$\overline{\text{EN}}$ = LOW	BDET = VIN - (r _{DS} x I _D)
8	$\overline{\text{FLAG}}$	Active LOW, open drain fault pin. Connect an external pull-up resistor to the system logic supply. $\overline{\text{FLAG}}$ is asserted during any fault condition.		
9, 10, 11, 12	VOUT	Power switch output to the load. The VOUT pins must be decoupled to GND via a minimum 1µF ceramic capacitor.		
MC	MC	Metal chassis. Connect to ground for electrical and thermal usage. MC is internally connected to GND.		

TDFN44-12
Top View

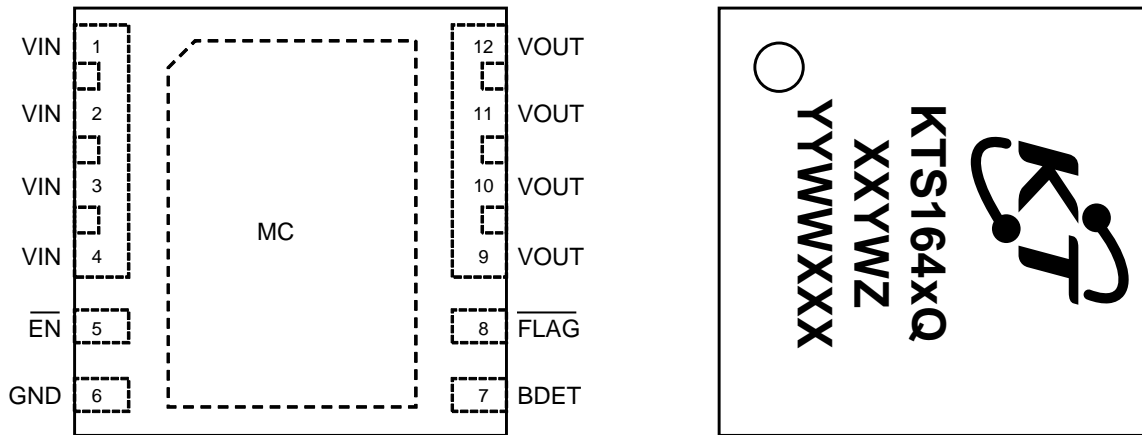

12-Lead 4.00mm x 4.00mm x 0.75mm
TDFN Package

Top Mark

KT Logo

KTS164xQ = Part Number
XX = Device ID Code, YWZ = Assembly Code
YYWWXXX = Serial Number

Absolute Maximum Ratings²

(T_A = 25°C unless otherwise noted)

Symbol	Description	Value	Units
V _{IN}	Input Voltage to GND	-30 to 42	V
V _{IN} to V _{OUT}	Input voltage to V _{OUT}	-30 to +42	V
V _{OUT} ,	Output Voltage to GND	-0.3 to +30	V
BDET	BDET output voltage to GND	-0.3 to +42	V
$\overline{\text{FLAG}}$, $\overline{\text{EN}}$,	$\overline{\text{FLAG}}$, $\overline{\text{EN}}$, pins to GND	-0.3 to 7	V
IBDET ³	Battery Detect Continuous Current	510	mA
I _{OUT}	V _{IN} to V _{OUT} Continuous Current	6	A
T _{STG}	Storage Temperature Range	-55 to 150	°C
T _J	Junction Operating Temperature	-40 to 150	°C
T _{LEAD}	Maximum Soldering Temperature (at leads, 10sec)	260	°C

Thermal Capabilities⁴

Symbol	Description	Value	Units
θ _{JA}	Thermal Resistance, Junction-to-Air	38	°C/W
P _D	Maximum Power Dissipation at 25°C	3.29	W
ΔP _D /ΔT	Derating Factor Above T _A = 25°C	-26.3	mW/°C

ESD Ratings

Symbol	Description	Conditions	Value	Units
V _{ESD}	IEC61000-4-2 Air Discharge	VIN Only	±15	kV
	IEC61000-4-2 Contact Discharge		±8	kV
	Human-body Model (HBM), per AEC Q100-002 ⁵	All Pins	±2	kV
	Charged-device Model (CDM), per AEC Q100-011 ⁶		±1	kV

2. Stresses above those listed in Absolute Maximum Ratings may cause permanent damage to the device. Functional operation at conditions other than the operating conditions specified is not implied. Only one Absolute Maximum rating should be applied at any one time.

3 Maximum output current pin limited. Output not short-circuit protected

4. Junction to Ambient thermal resistance is highly dependent on PCB layout. Values are based on thermal properties of the device when soldered to an EV board.

5. Follows ANSI/ESDA/JEDEC JS-001

6. Follows ANSI/ESD S5.3.1-2009

Ordering Information

Part Number	Marking ⁷	OVP	Fault Response	Ambient Operating Temperature	Package
KTS1640QGDV-TR	MRYWZ	27V	Auto Retry	-40°C to +125°C	TDFN44-12
KTS1641QGDV-TR	MZYWZ	20.3V	Auto Retry	-40°C to +125°C	TDFN44-12

Recommended Operating Range

Description	System Condition	Value
Input Voltage	NORMAL	6V to +24V
	PROTECTED	-28V to +40V
Continuous Output Current	NORMAL	Up to 6A
BDET Output Current ⁸	NORMAL	500mA max
Operating Temperature	ALL	-40°C to +125°C

7. "XXYWZ" is the device code, date code and assembly code.

8. Output not short circuit protected

Electrical Characteristics⁹

Unless otherwise noted, the *Min* and *Max* specs are applied over the full operation temperature range of -40°C to +125°C. Typical values are specified at room temperature (25°C) with $V_{IN} = 14V$, $I_{OUT} \leq 5A$, $\overline{EN} = \text{LOW}$, $\overline{FLAG} = \text{OPEN}$, $C_{IN} = 1.0\mu F$, $C_{OUT} = 1.0\mu F$, $C_{BDET} = 100nF$ and $T_A = 25^\circ C$.

Symbol	Description	Conditions	Min	Typ	Max	Units	
INPUT							
I_Q	Input Quiescent Current			145	200	μA	
I_{LK}	Input Leakage Current	$\overline{EN} = \text{HIGH}$, No load		5	8	μA	
I_{LK_RB}	Input Leakage Current in Reverse Battery	$V_{IN} = -28V$, $\overline{EN} = \text{HIGH}$, No load		52	70	μA	
I_{OVLO_Q}	Input Supply Current in Over-voltage mode	KTS1641Q	$V_{IN} = 20.3V$		150	180	μA
		KTS1640Q	$V_{IN} = 27V$		150	180	μA
V_{IN_UVLO}	Under Voltage Lockout	V_{IN} Rising		5.5	5.7	5.9	V
		V_{IN} Falling		5.3	5.5	5.7	V
OUTPUT							
R_{ON_OUT}	On-resistance V_{IN} to V_{OUT}	$I_{OUT} = 1A$	$T_A = 25^\circ C$		41	50	$m\Omega$
		$I_{OUT} = 5A$			44.5		$m\Omega$
V_{OUT_OVLO}	Over-Voltage Trip Level	V_{IN} Rising	KTS1640Q	26.2	27	27.8	V
		V_{IN} Falling		25.6			V
		V_{IN} Rising	KTS1641Q	19.5	20.3	21.1	V
		V_{IN} Falling		17.9			V
I_{OUT_RC}	OUT Reverse Current	$V_{IN} = 0V$, $V_{OUT} = 28V$, $T_A = 25^\circ C$		38		μA	
DIGITAL SIGNALS (\overline{FLAG}, \overline{EN})							
V_{FLAG_OL}	\overline{FLAG} Output Low Voltage	$V_{IO} = 5V$, sinking 1.0mA			0.5	V	
I_{FLAG}	\overline{FLAG} Leakage Current	$V_{IO} = 5V$			1	μA	
V_{EN_IH}	\overline{EN} High Voltage	$V_{IO} = 5V$	1.2			V	
V_{EN_IL}	\overline{EN} Low Voltage	$V_{IO} = 5V$			0.35	V	
I_{EN}	\overline{EN} Leakage Current	$V_{IO} = 5V$			4	μA	
TIMING CHARACTERISTICS (Figures 1 – 3)							
t_{OUT_DB}	V_{OUT} Debounce Time	Time from $V_{IN} = V_{IN_UVLO}$ to 10% of V_{OUT}		2		ms	
t_{ON_OUT}	OUT Switch Turn-on Time	V_{OUT} from 10% of V_{IN} to 90% of V_{IN} , $R_L = 100\Omega$, $C_L = 22\mu F$		10		ms	
$t_{OFF_OUT_F}$	OUT Switch Turn-Off Time Under Fault Conditions or by \overline{EN} ¹⁰	$V_{IN} > V_{OUT_OVLO}$ to V_{OUT} Stop rising, $R_L = 100\Omega$, No C_L , $\overline{EN} = \text{Low}$		0.5		μs	

9. KTS1640Q and KTS1641Q are guaranteed to meet performance specifications over the -40°C to +125°C ambient operating temperature range by design, characterization and correlation with statistical process controls.

10. Guaranteed by characterization and design

Electrical Characteristics⁹

Unless otherwise noted, the *Min* and *Max* specs are applied over the full operation temperature range of -40°C to +125°C. Typical values are specified at room temperature (25°C) with $V_{IN} = 14V$, $I_{OUT} \leq 5A$, $\overline{EN} = LOW$, $FLAG = OPEN$, $C_{IN} = 1.0\mu F$, $C_{OUT} = 1.0\mu F$, $C_{BDET} = 100nF$ and $T_A = 25^\circ C$.

Symbol	Description	Conditions	Min	Typ	Max	Units
TIMING CHARACTERISTICS Cont. (Figures 1 – 3)						
$t_{EN(ON)}$	Switch Turn-ON	\overline{EN} High to Low, V_{OUT}		14		ms
$t_{EN(OFF)}$	Switch Turn-OFF	\overline{EN} Low to High, V_{OUT} falls to 90% V_{OUT} , $R_L = 100\Omega$, No C_L		200		μs
THERMAL SHUTDOWN						
T_{SHDN}	Shutdown Temperature			165		$^\circ C$
	Shutdown Temperature Hysteresis			20		$^\circ C$

Typical Characteristics

VIN = 14V, \overline{EN} = GND, CIN = 1 μ F, COUT = 1 μ F, CBDET = 100nF, TA = 25°C unless otherwise specified.

Input Supply Current vs. VIN (no load)

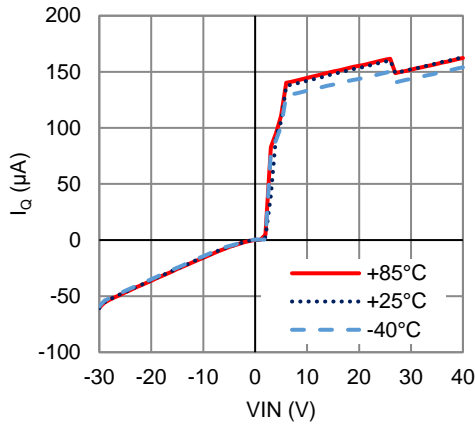

Input Supply Current vs. Temperature

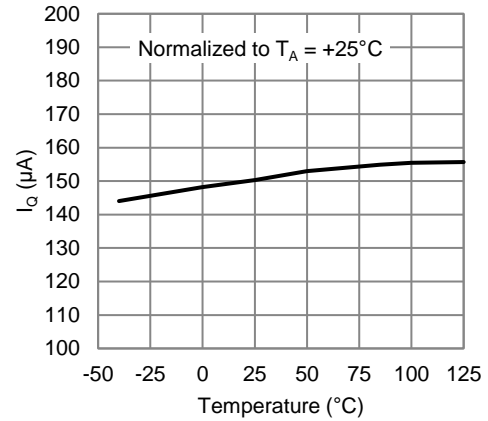

Normalized RON_OUT vs. Output Current

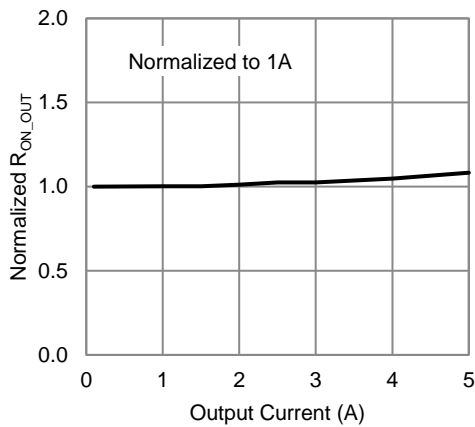

Normalized RON_OUT vs. Temperature

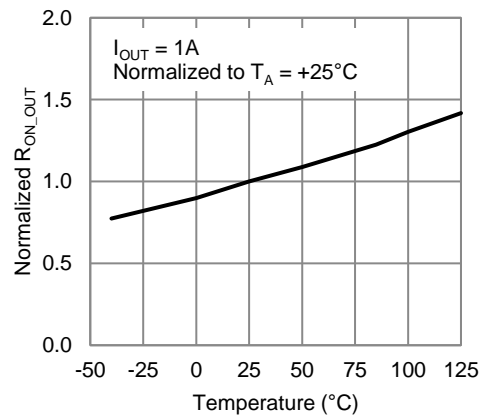

Normalized OVLO Threshold vs. Temperature

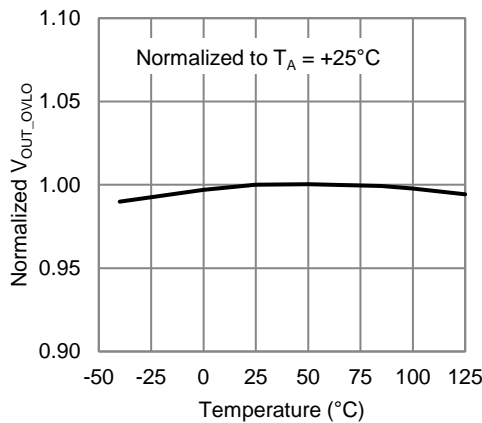

Enable Logic Threshold vs. VIN

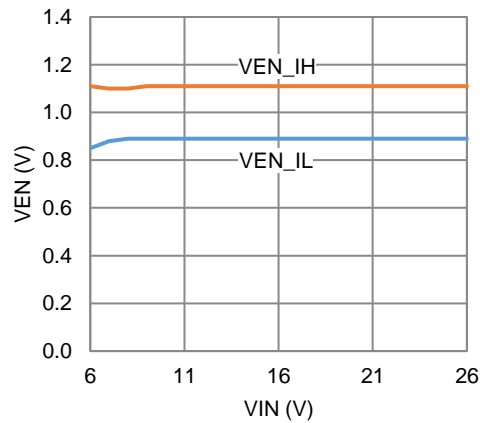

Typical Characteristics

VIN = 14V, \overline{EN} = LOW, CIN = 1 μ F, COUT = 1 μ F, CBDET = 100nF, TA = 25°C unless otherwise specified.

Normalized Debounce Time vs. Temperature

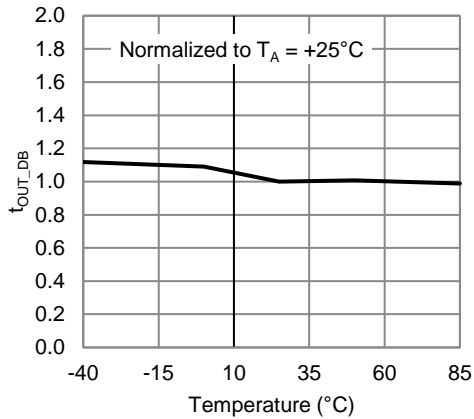

Power Up and Down (100 Ω load)

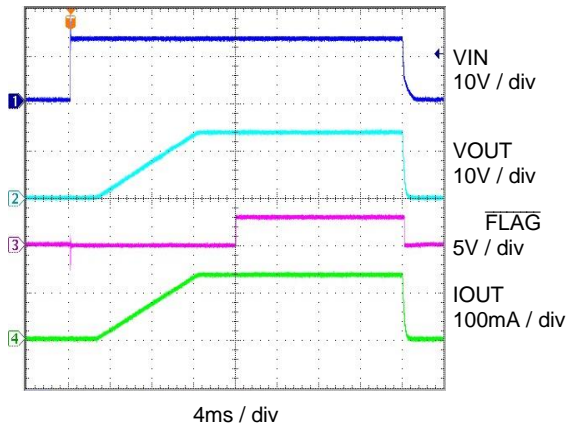

Turn On and Off by Enable

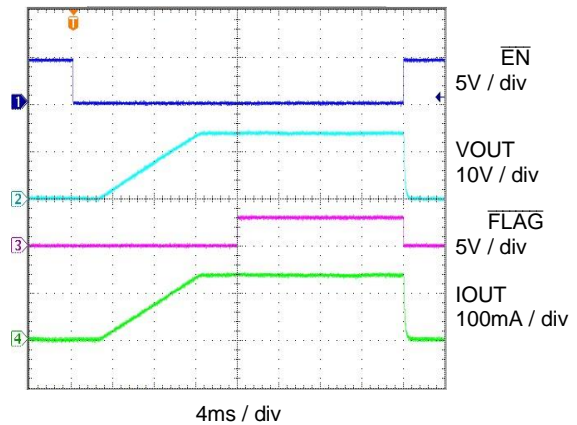

OVP Transient

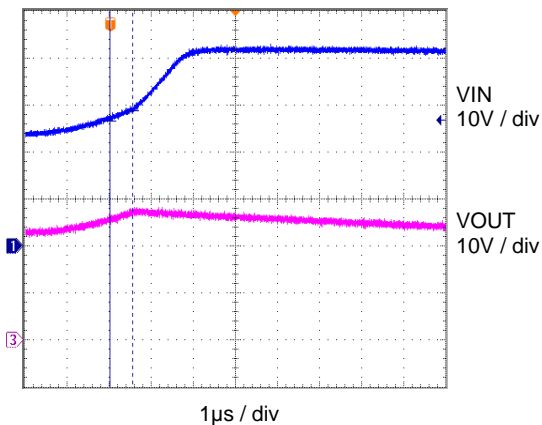

Power-up with BDET

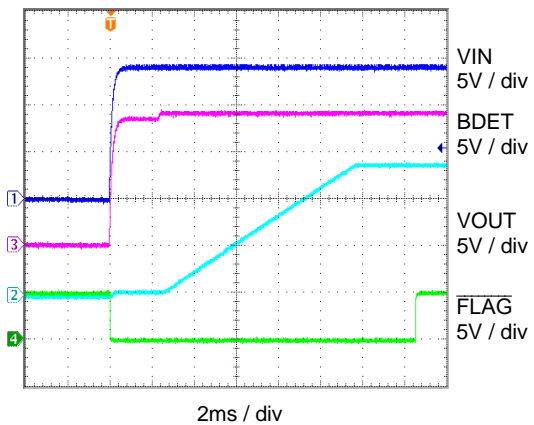

Timing Diagrams¹¹

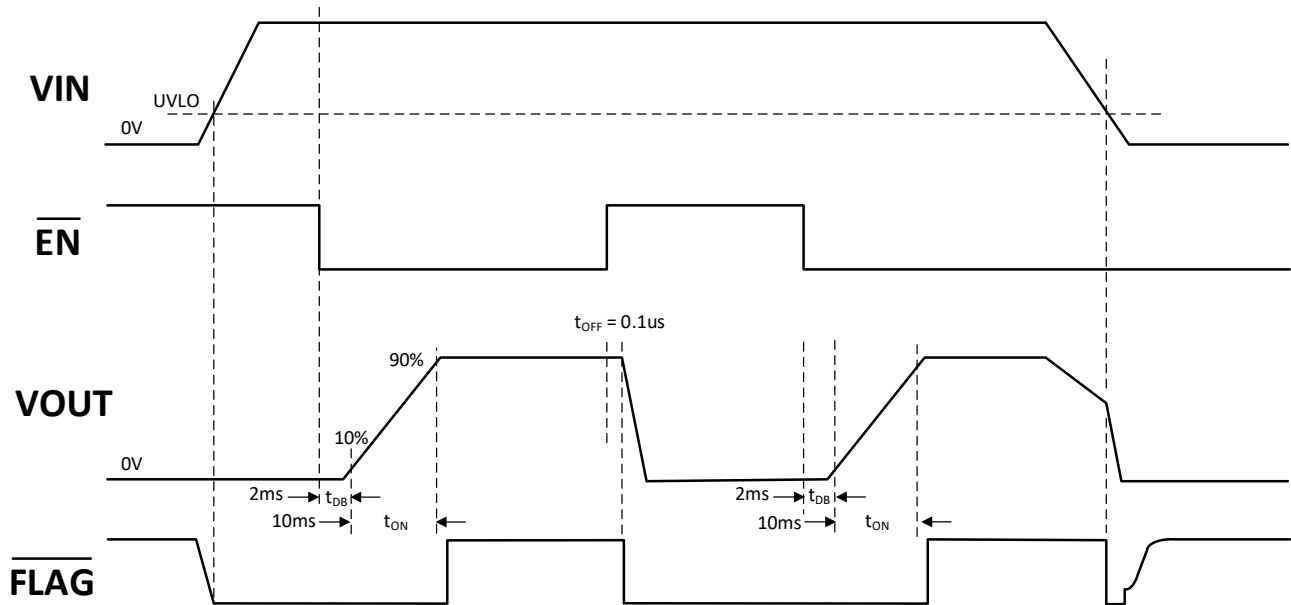

Figure 1. TURN-ON/TURN-OFF, When $V_{IN} = 0V$, $\overline{EN} = H$

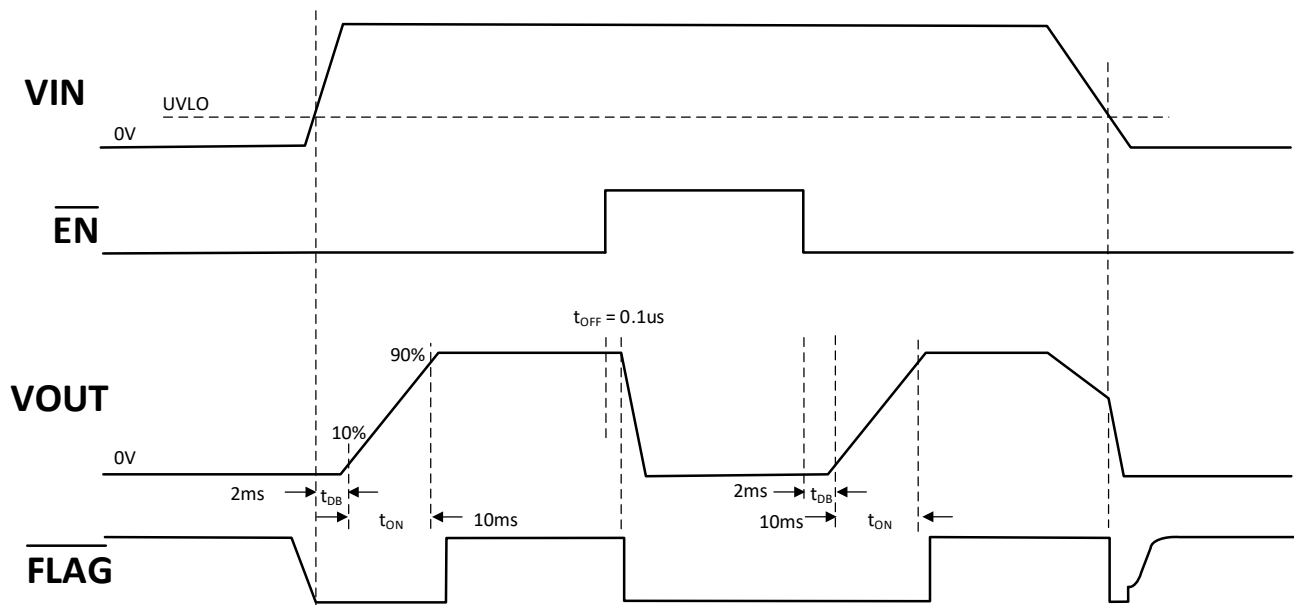

Figure 2. TURN-ON/TURN-OFF, When $V_{IN} = 0V$, $\overline{EN} = L$

11. All timing diagrams are for illustration purposes only and not to scale.

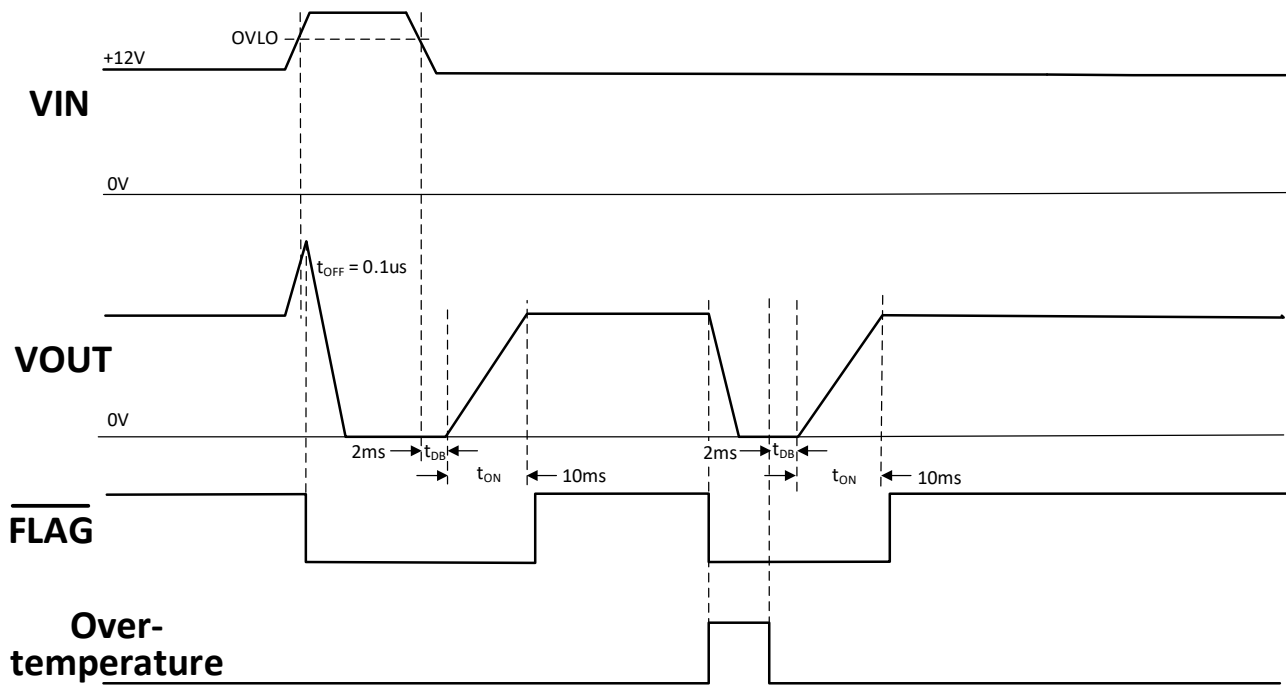
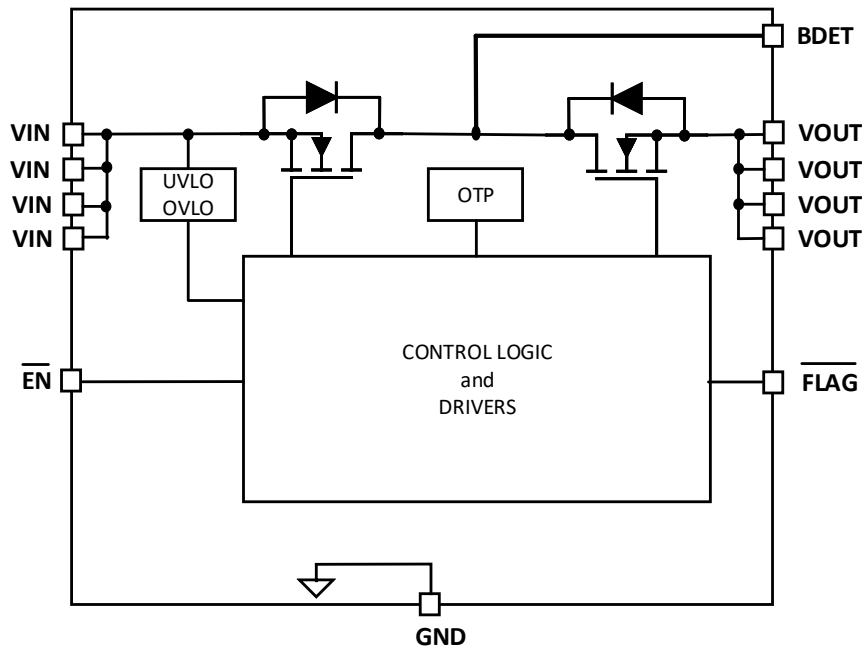

Figure 3. Over-voltage and Over-temperature, $\overline{EN} = L$

Functional Block Diagram



Functional Description

The KTS1640Q and KTS1641Q are low-resistance, electronically controlled load switches, with enhanced protection features, used to protect loads from abnormal power supply or load problems. Operating from a wide input supply voltage of between 6V and 40V, the KTS1640Q and KTS1640Q protects the system from reverse input supplies down to -28V, over-voltage conditions, over-temperature and output short-circuits.

The KTS1640Q and KTS1640Q integrates two low-resistance, active LOW enabled, N-Channel MOSFETs, in common drain configuration. The first MOSFET will provide protection to the system if the battery supply is accidentally reversed. The second MOSFET provides the controlled turn-on and protection of the battery voltage to the system load. The KTS1640Q includes fixed over-voltage protection of $27V \pm 0.8V$, while the KTS1641Q includes fixed over-voltage protection of typical $20.3V \pm 0.8V$. Both devices also include over-temperature protection with auto-retry¹².

An ENABLE \overline{EN} pin allows the MOSFET switch to be enabled or disabled, placing the device in a low current shutdown mode. System monitoring is provided by a digital output fault \overline{FLAG} . When a fault condition occurs, the fault \overline{FLAG} is pulled down to GND. An external pull-up resistor connected to the system power supply is required.

Further protection includes ESD protection and the input pin is fully protected to comply with the IEC61000-4-2 (Level 4) specification.

Internal MOSFET Switch

In normal operating mode (main power switches turned on), the \overline{EN} input must be set to the logic low state ($\overline{EN} = GND$). The KTS1640Q and KTS1641Q integrates two N-Channel power MOSFET in a back-to-back configuration with ultra-low 41mΩ (typical) on-resistance between VIN and OUT. The MOSFETs are internally driven by a charge pump supply that generates a gate voltage (VGS) greater than VIN.

To prevent downstream systems from being damaged by a reverse battery condition, the KTS1640Q and KTS1641Q includes an integrated synchronous MOSFET Diode to protect against voltages down to -28V.

12. For an alternative response to fault conditions, please contact marketing

Under-voltage Lockout

When the input voltage V_{IN} is below the normal operating range, either during operation or start-up, the internal switch will turn-off and the fault flag asserted low. The UVLO is internally set to 5.7V typical with 200mV hysteresis.

Over-voltage Lockout Protection

The KTS1640Q and KTS1641Q features a fixed over-voltage threshold of 27V typical (KTS1640Q) or 20.3V typical (KTS1641Q). If V_{IN} is above this threshold, the internal MOSFET switches are turned OFF and OUT is disconnected from V_{IN} , protecting the load. \overline{FLAG} is asserted low during the over-voltage period. Once the over-voltage condition is removed the switch will automatically restart.

Battery Present Output

BDET provides an unregulated output, whenever V_{IN} is present. When the switch is enabled, BDET is equal to V_{IN} less the voltage dropped across the input MOSFET ($V = r_{DS} \times I_{SW}$). When the switch is disabled, BDET is equal to V_{IN} less one diode drop, due to the reverse battery protection MOSFET ($BDET = V_{IN} - V_F$ (~0.7V)). This output is capable of supplying up to a maximum of 500mA output current. However, care should be taken not to exceed this value as this pin is not short-circuit protected.

Over-temperature Protection

During an over-temperature event, KTS1640Q and KTS1641Q will immediately turn OFF both switches and \overline{FLAG} will be asserted low. The over-temperature threshold is 165°C typical.

Once T_J falls by 20°C the device automatically retries and will continually retry indefinitely.

The \overline{FLAG} signal remains asserted low until the fault condition is removed and the device resumes normal operation.

Application Information

Input Capacitor

A 1 μ F or larger capacitor is typically recommended for C_{IN}. C_{IN} should be located as close to the device VIN pin as practically possible. 50V rated capacitors are recommended to support input voltage up to 40V.

Output Capacitor

The soft-start function provides a slow turn-on that allows the device to charge large output capacitors with minimum in-rush current. It is recommended to bypass V_{OUT} pin with a 1 μ F minimum ceramic capacitor with 35V rating.

Recommended PCB Layout

For high output current, the power dissipation may be large. The TDFN package allows to dissipate well the heat to the PCB when using proper PCB layout technic. To improve the board thermal conductivity, large copper area around GND, VIN and VOUT pins are recommended. Thermal vias under the package exposed center pad help to spread the heat throughout the board ground plane.

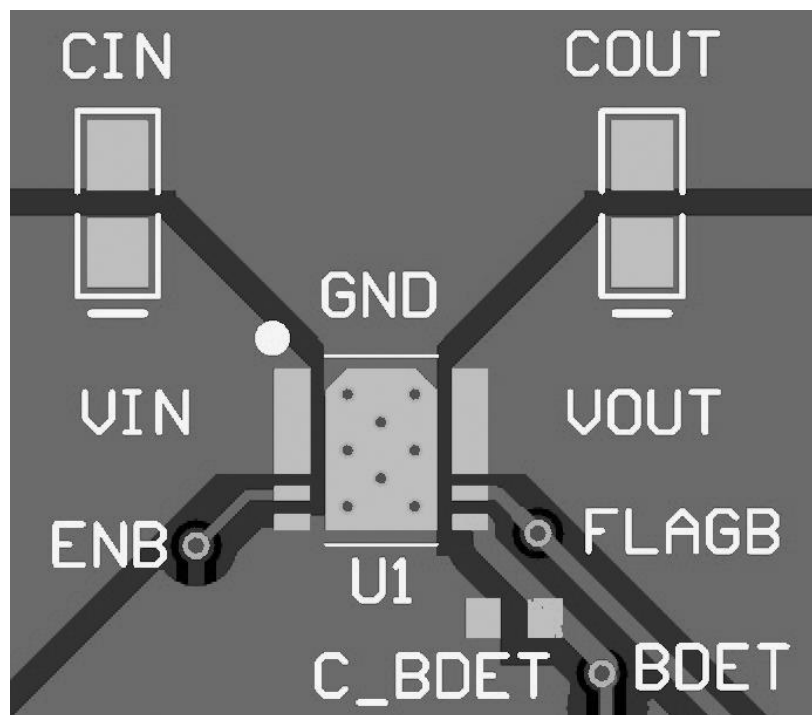
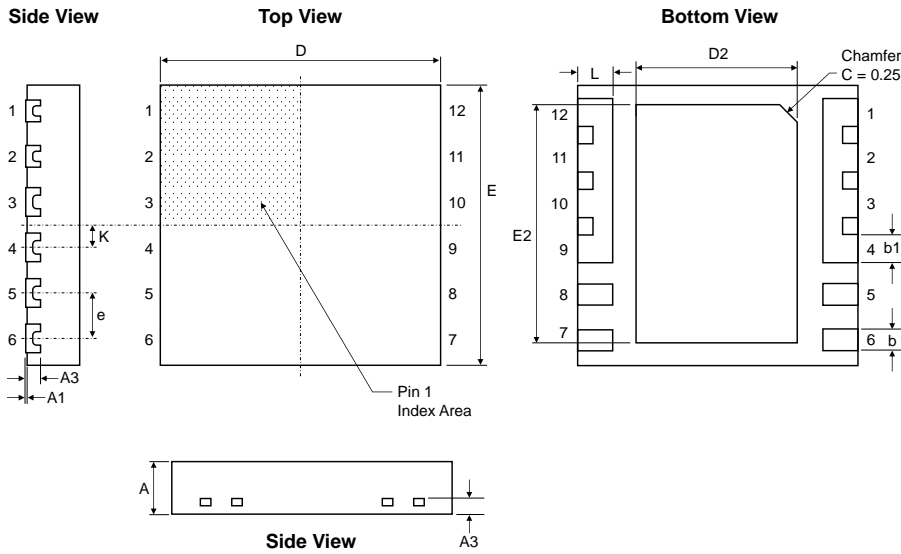

Figure 4. Recommended PCB Layout

Package Information

TDFN44-12 (4.00mm x 4.00mm x 0.75mm)



Dimension	mm		
	Min.	Typ.	Max.
A	0.70	0.75	0.80
A1	0.00	0.02	0.05
A3	0.203 REF		
b	0.25	0.30	0.35
b1	0.35	0.40	0.45
D	3.90	4.00	4.10
D2	2.25	2.30	2.35
E	3.90	4.00	4.10
E2	3.35	3.40	3.45
e	0.650 BSC.		
L	0.45	0.50	0.55
K	0.035 REF		

Recommended Footprint

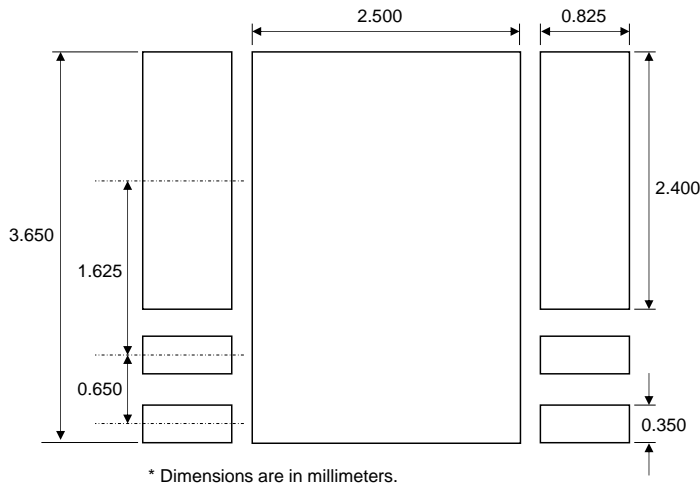

Kinetic Technologies cannot assume responsibility for use of any circuitry other than circuitry entirely embodied in a Kinetic Technologies product. No intellectual property or circuit patent licenses are implied. Kinetic Technologies reserves the right to change the circuitry and specifications without notice at any time.