

Flat-Clamp Mini TVS for High Voltage Surge & ESD Protection

Brief Description

The KTS1289 Evaluation (EVAL) Kit is used to demonstrate and evaluate the KTS1289 functionality, performance, and PCB layout. The kit includes a fully assembled and tested PCB with the KTS1289 IC installed, two pairs of high-current XT30-to-Banana power cables, and a printed copy of the Quick Start Guide.

Ordering Information

Part Number	Description	IC Package
KTS1289ECAE-MMEV01	KTS1289 EVAL Kit	WLCSP-6

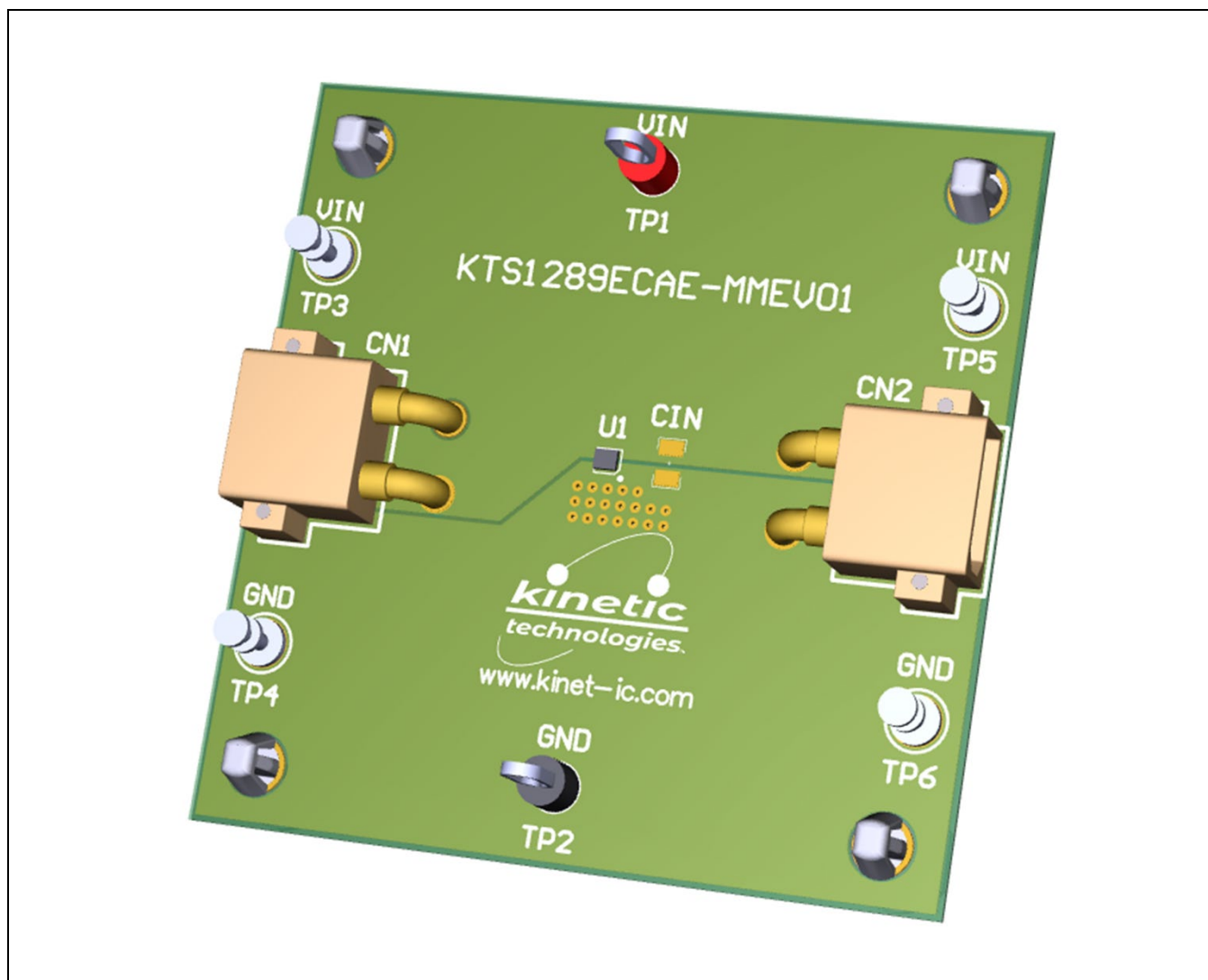

3D CAD Image



EVAL Kit Physical Contents

Item #	Description	Quantity
1	KTS1289 EVAL fully assembled PCB	1
2	XT30-to-Banana power cables, red/black pair	2 pairs
3	Anti-static bag	1
4	Quick Start Guide, printed 1 page (A4 or US Letter)	1
5	EVAL Kit box	1

QR Links for Documents

IC Landing Page	EVAL Kit Landing Page
 https://www.kinet-ic.com/kts1289/	 https://www.kinet-ic.com/kts1289ecae-mmew01/

User-Supplied Equipment

Required Equipment

1. Digital Multimeter - one or more, used to measure IN – GND Diode.
2. Surge Tester - Test the TVS surge capability

Optional Equipment

1. Oscilloscope – for dynamic testing of clamping voltages (and surge currents with a current probe, if available).

Recommended Operating Conditions

Symbol	Description	Value	Units
V _{IN}	Nominal Input Voltage Range	0 to 33	V
V _{BR}	Reverse Breakdown Voltage (I _{IN} = 1mA)	33.6 to 37.5	V
V _F	Forward Voltage (I _{IN} = -1mA)	-0.8 to -0.4	A

Quick Start Procedures

1. Use a digital multimeter to check the TVS diode value. it should be close to 0.7V.
2. Use the oscilloscope to capture the surge clamping voltage waveform during surge event.

Typical Test Setup Diagram

As an example, use the following test setup to test KTS1289 surge capability.

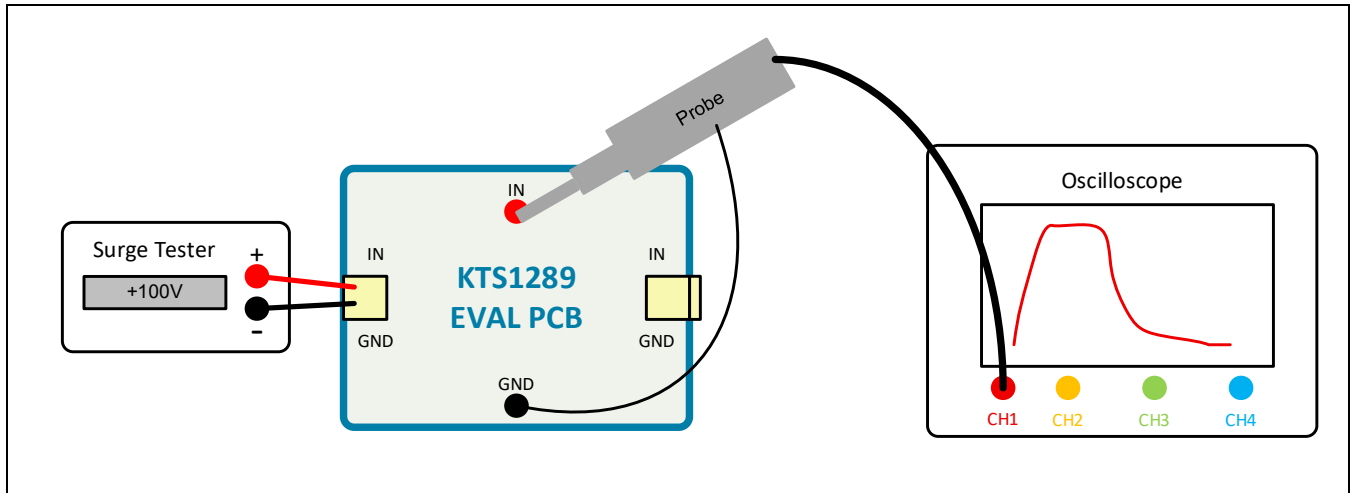

Electrical Schematic

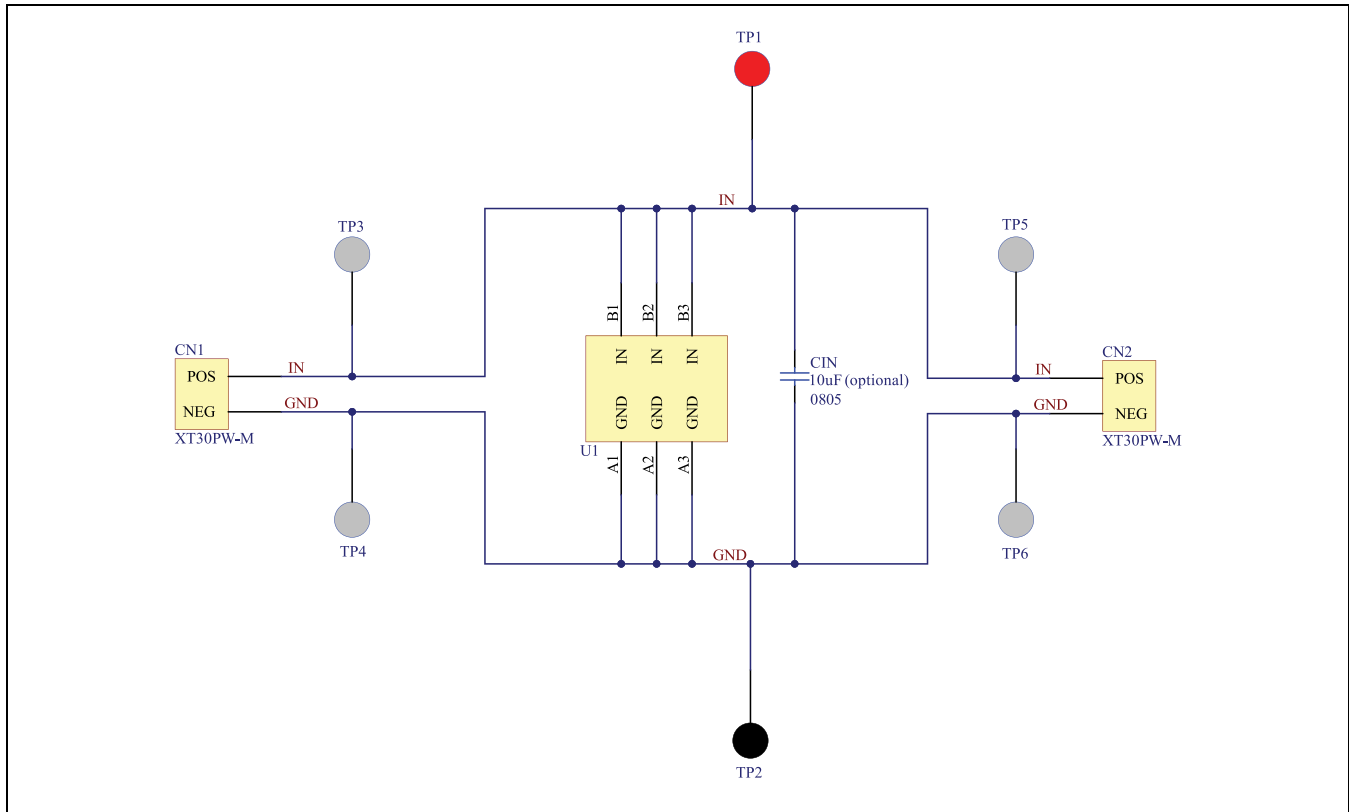

Bill of Materials (BOM)

Designator	Description	Quantity	Value	Manufacturer	Manufacturer Part Number
CIN	CAP CER 10µF 50V X5R 0805 (Optional)	1	10µF (optional)	Samsung	CL21A106KBYQNNE
CN1, CN2	30A Right Angle Through Hole Power Connectors	2		AMASS	XT30PW-M
H1, H2, H3, H4	BRD SPT SNAP LOCK REST MNT 4MM	4		Essentra Components	PSD-4M-19
U1	Flat-Clamp Mini TVS for High Voltage Surge & ESD Protection	1		Kinetic Technologies	KTS1289ECAE-TA
TP1	PC TEST POINT MULTIPURPOSE RED	1		Keystone	5010
TP2	PC TEST POINT MULTIPURPOSE BLACK	1		Keystone	5011
TP3, TP4, TP5, TP6	TERM TURRET SINGLE L=5.56MM TIN	4		Keystone	1502-2

Printed Circuit Board (PCB)

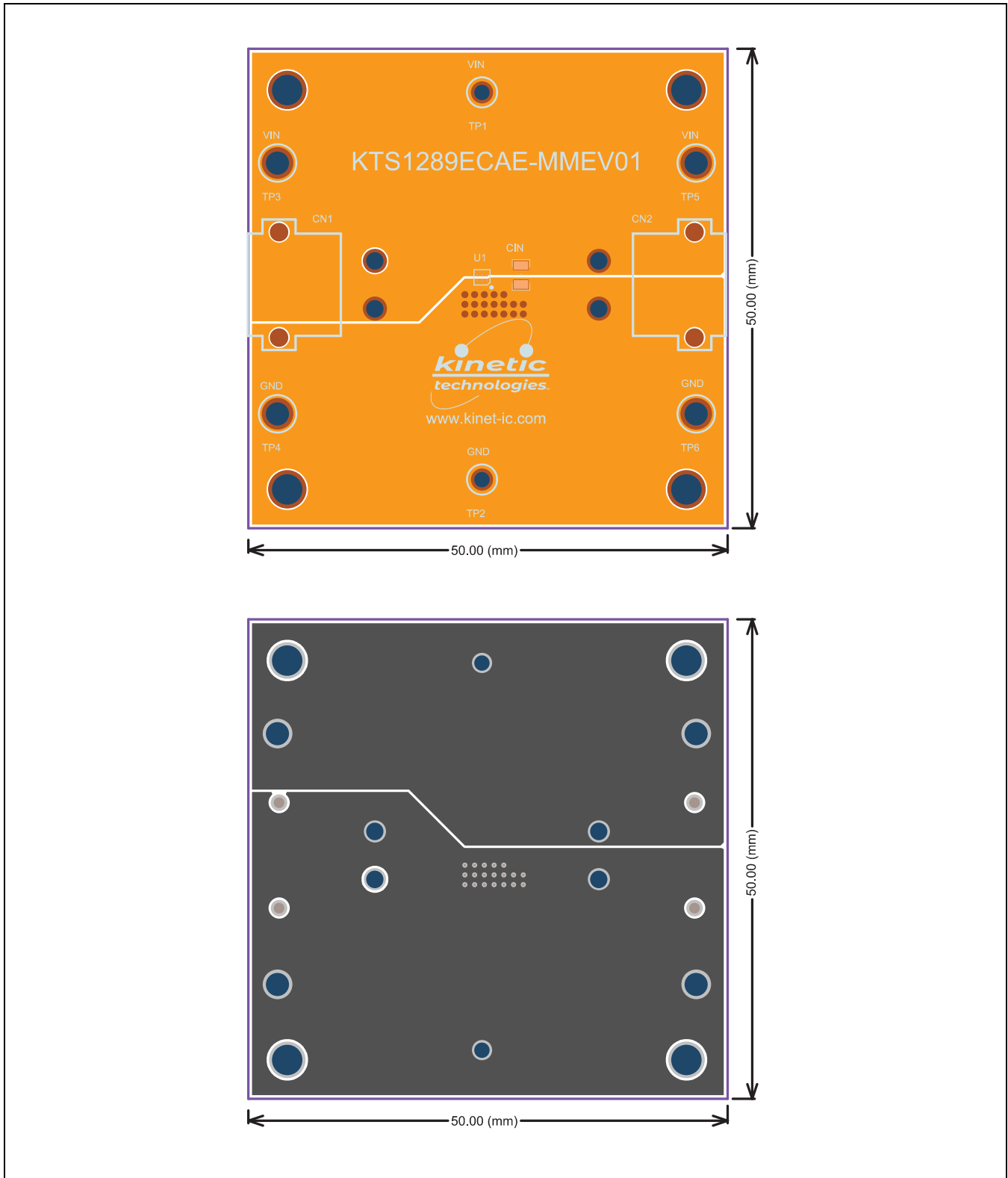

Adding Additional Input Capacitance

Optional Input Capacitance C_{IN}

The KTS1289 works equally well with or without an input capacitor. However, in most cases, input capacitors are required to support other circuits within the application. The recommended voltage rating of the capacitor depends upon the clamping voltage of the TVS version during a surge event. For maximum surge protection, a 50V rated capacitor or higher is recommended. USB standards limit the total capacitance from VBUS to GND to 10 μ F maximum. Various ICs in the host system may require local bypass capacitance; therefore, the total remaining capacitance available for use at the port may be reduced. If the total system capacitance on VBUS is not easily limited to 10 μ F or less, use a USB protection load-switch with soft-start, such as available from Kinetic Technologies, to isolate large capacitance from the port. These are available with or without integrated TVS, but the integrated solution guarantees that the TVS and load-switch are designed and specified to work together.

Evaluating Other ICs

This EVAL Kit may optionally be used to evaluate the similar KTS1287 series TVS for high voltage surge & ESD protection. Before ordering samples of these devices, please confirm capability to reflow and exchange WLCSP devices.

Troubleshooting

Symptom	Root Cause	Solution
IN pin short to GND	The TVS is damaged or connected in reverse	Replace TVS or check the connect cable

Important Notices

Legal notice

Copyright © Kinetic Technologies. Other names, brands and trademarks are the property of others.

Kinetic Technologies assumes no responsibility or liability for information contained in this document. Kinetic Technologies reserves the right to make corrections, modifications, enhancements, improvements, and other changes to its products and services at any time and to discontinue any product or services without notice. The information contained herein is believed to be accurate and reliable at the time of printing.

Reference design policy

This document is provided as a design reference and Kinetic Technologies assumes no responsibility or liability for the information contained in this document. Kinetic Technologies reserves the right to make corrections, modifications, enhancements, improvements, and other changes to this reference design documentation without notice.

Reference designs are created using Kinetic Technologies' published specifications as well as the published specifications of other device manufacturers. This information may not be current at the time the reference design is built. Kinetic Technologies and/or its licensors do not warrant the accuracy or completeness of the specifications or any information contained therein.

Kinetic Technologies does not warrant that the designs are production worthy. Customer should completely validate and test the design implementation to confirm the system functionality for the end use application.

Kinetic Technologies provides its customers with limited product warranties, according to the standard Kinetic Technologies terms and conditions.

For the most current product information visit us at www.kinet-ic.com

Life support policy

LIFE SUPPORT: KINETIC TECHNOLOGIES' PRODUCTS ARE NOT DESIGNED, INTENDED, OR AUTHORIZED FOR USE AS COMPONENTS IN LIFE SUPPORT DEVICES OR SYSTEMS. NO WARRANTY, EXPRESS OR IMPLIED, IS MADE FOR THIS USE. AUTHORIZATION FOR SUCH USE SHALL NOT BE GIVEN BY KINETIC TECHNOLOGIES, AND THE PRODUCTS SHALL NOT BE USED IN SUCH DEVICES OR SYSTEMS, EXCEPT UPON THE WRITTEN APPROVAL OF THE PRESIDENT OF KINETIC TECHNOLOGIES FOLLOWING A DETERMINATION BY KINETIC TECHNOLOGIES THAT SUCH USE IS FEASIBLE. SUCH APPROVAL MAY BE WITHHELD FOR ANY OR NO REASON.

“Life support devices or systems” are devices or systems which (1) are intended for surgical implant into the human body, (2) support or sustain human life, or (3) monitor critical bodily functions including, but not limited to, cardiac, respirator, and neurological functions, and whose failure to perform can be reasonably expected to result in a significant bodily injury to the user. A “critical component” is any component of a life support device or system whose failure to perform can be reasonably expected to cause the failure of the life support device or system, or to affect its safety or effectiveness.

SUBSTANCE COMPLIANCE

Kinetic Technologies IC products are compliant with RoHS, formally known as Directive 2002/95/EC of the European Parliament and of the Council of 27 January 2003 on the restriction of the use of certain hazardous substances in electrical and electronic equipment. However, this evaluation kit does not fall within the scope of the EU directives regarding electromagnetic compatibility, restricted substances (RoHS), recycling (WEEE), FCC, CE or UL, and may not meet the requirements of these or related directives. To the best of our knowledge the information is true and correct as of the date of the original publication of the information. Kinetic Technologies bears no responsibility to update such statement.