

High Accuracy 2.5A Low-Voltage AOT Synchronous Buck Regulator

Features

- Operating Range
 - ▶ 2.5 to 5.5V Input Voltage Range
 - ▶ Output voltage options from 0.3V to 3.3V¹
 - ▶ Up to 2.5A Output Current
- Adaptive On-Time Control
 - ▶ Fast and accurate transient response
 - ▶ Seamless transitions between Auto-skip and PWM operation
 - ▶ Optimized for smallest solution size and external components
- Integrated High-Side / Low-Side FETs
- $\pm 0.75\%$ Output Voltage Accuracy
- Peak Efficiency up to 90% for $V_{OUT} = 1.8V$ at 4MHz
- 39 μA quiescent supply current
- Switching frequency options 1MHz, 2MHz and 4MHz
- Forced-PWM or Auto-Skip Modes
- Over-Current and Short-Circuit protection
- UVLO and Thermal Shutdown Protected
- Active high Enable pin compatible with 1.2V logic
- Active Output Discharge in shutdown mode
- -40°C to 85°C Operating Temperature Range
- PwrCSP™ HP-WLCSP-6 1.464mm x 1.064mm

Brief Description

The KTB8316/KTB8311 is a precision adaptive-on-time (AOT) step-down (buck) switching regulator. The device has class-leading accuracy, fast transient response and high efficiency. Additional features include over current, over/under voltage and thermal protections.

The AOT control along with a thermally enhanced PwrCSP™ package provides a best in class solution with reduced size external components. The step-down buck regulator operates over a user set 0.3V to 3.3V¹ output range.

Switching frequency options of 1MHz, 2MHz and 4MHz are available with Forced-PWM or Auto-skip mode at light loads.

The KTB8316/KTB8311 is available in RoHS and Green compliant PwrCSP™ HP-WLCSP-6 Package.

Applications

- Smartphones, Mobile Internet Devices, IoT
- Tablets, Notebooks
- Wearable and portable electronic devices
- Digital Still Cameras (DSC), Drones
- Gaming Consoles and Accessories

Typical Application

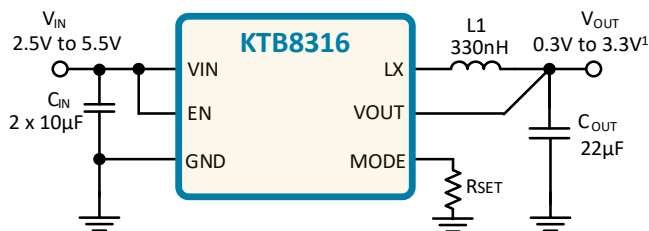

Efficiency ($V_{OUT} = 1.8V$, $f_{sw} = 4MHz$)

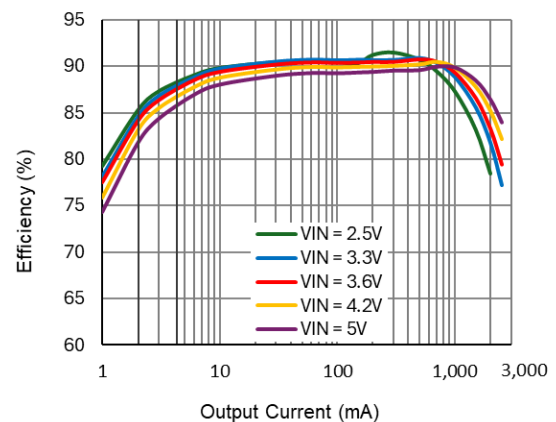

1. Refer to Ordering Information for specific product output ranges.

Ordering Information

Part Number	Marking ²	Factory Options			Package
		F _{sw}	Default V _{OUT}	Output Voltage range	
KTB8316EEAA-AA-TA ³	VJYWZNAABB	1MHz	0.6V	0.3V to 1.65V	PwrCSP™ HP-WLCSP-6
KTB8316EEAA-BD-TA	VKYWZNAABB	2MHz	1.2V	0.6V to 1.8V	
KTB8311EEAB-BT-TA ³	VYYWZNAABB	2MHz	2.2V	0.5V to 3.3V	
KTB8316EEAA-CJ-TA	UFYWZNAABB	4MHz	1.2V	0.9V to 3.3V	

Pinout Diagram

PwrCSP™ HP-WLCSP-6

Top View

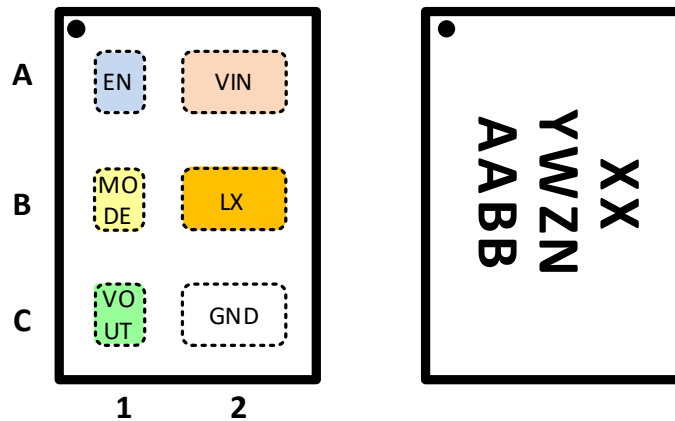

6-Bump 1.464mm x 1.064mm x 0.460mm
PwrCSP™ package, 0.444mm pitch

Top Mark

XX = Device ID, YW = Date Code, ZN = Assembly Code, AABB = Serial Number

Pin Descriptions

Pin #	NAME	Description
A1	EN	Chip Enable logic input. Active-high enable
A2	VIN	Voltage Input for buck regulator and IC power
B1	MODE	MODE option selection input: 1. MODE pin to logic high for Forced-PWM (FPWM). 2. MODE pin to logic low for Auto-skip Mode. 3. MODE pin connect to R _{SET} resistor to ground for other Output Voltage options
B2	LX	Switching node pin – Internally connected to the high-side MOSFET Drain and low-side MOSFET Drain. This pin is connected to the inductor.
C1	VOUT	Output voltage sense input pin
C2	GND	Power Ground for buck regulator

2. XX = Device ID, YW = Date Code, ZN = Assembly Code, AABB = Serial Number.

3. Consult Kinetic Technologies authorized representative for availability.

Absolute Maximum Ratings⁴

(T_A = 25°C unless otherwise noted)

Symbol	Description	Value	Units
V _{IN}	VIN to GND	-0.3 to 6	V
V _{LX}	LX to GND	-0.3 to (V _{IN} +0.3)	V
V _{OUT}	VOUT to GND	-0.3 to (V _{IN} +0.3)	V
V _{IO}	EN, MODE to GND	-0.3 to V _{IN}	V
T _J	Operating Junction Temperature Range	-40 to 150	°C
T _S	Storage Temperature Range	-55 to 150	°C
T _{LEAD}	Maximum Soldering Temperature (at leads, 10 sec)	260	°C

ESD and Surge Ratings⁵

Symbol	Description	Value	Units
V _(ESD)	Human body model (HBM)	±8000	V
	Charged device model (CDM)	±1000	V

Thermal Capabilities⁶

Symbol	Description	Value	Units
θ _{JA}	Thermal Resistance – Junction to Ambient	69	°C/W
P _D	Maximum Power Dissipation at T _A = 25°C	1.45	W
ΔP _D /ΔT	Derating Factor Above T _A = 25°C	-14.5	mW/°C

Recommended Operating Conditions

Symbol	Description	Value	Units
V _{IN}	Supply Voltage	2.5 to 5.5	V
V _{OUT}	Output Voltage	KTB8316EEAA-AA, F _{SW} = 1MHz ⁷	0.3 to 1.65
		KTB8316EEAA-BD, F _{SW} = 2MHz	0.6 to 1.8
		KTB8311EEAB-BT, F _{SW} = 2MHz ⁷	0.5 to 3.3
		KTB8316EEAA-CJ, F _{SW} = 4MHz	1.0 to 3.3
I _{OUT}	Output Current		0 to 2
		V _{IN} ≥ 3.1V & T _A = -40°C to +85°C	0 to 2.5
T _A	Ambient temperature	-40 to 85	°C
T _J	Junction temperature	-40 to 125	°C

4. Stresses above those listed in Absolute Maximum Ratings may cause permanent damage to the device. Functional operation at conditions other than the operating conditions specified is not implied. Only one Absolute Maximum rating should be applied at any one time.

5. ESD and Surge Ratings conform to JEDEC and IEC industry standards. Some pins may have higher performance. Surge ratings apply with chip enabled, disabled, or unpowered, unless otherwise noted.

6. Junction to Ambient thermal resistance is highly dependent on PCB layout. Values are based on thermal properties of the device when soldered to an EV board.

7. Consult Kinetic Technologies authorized representative for availability.

Electrical Characteristics⁸

Unless otherwise noted, the *Min and Max specs* are applied over the full Junction operation temperature range of $T_J = -40^{\circ}\text{C}$ to $+125^{\circ}\text{C}$ and $V_{IN} = 2.5\text{V}$ to 5.5V . *Typical* values are specified at $T_A = +25^{\circ}\text{C}$, $V_{IN} = 3.6\text{V}$, with $V_{OUT} = 1.2\text{V}$. $L = 330\text{nH}$, $f_{sw} = 4\text{MHz}$

Supply Specifications

Symbol	Description	Conditions	Min	Typ	Max	Units
V_{IN}	Input Supply Operating Range		2.5		5.5	V
V_{UVLO}	Under-Voltage Lockout Threshold	V_{IN} rising		2.3	2.49	V
		V_{IN} hysteresis		200		mV
V_{OVP}	Over-Voltage Protection Threshold	V_{IN} rising		5.8		V
		V_{IN} hysteresis		200		mV
I_Q	Quiescent Supply Current	EN = 1, $V_{IN} = 3.6\text{V}$, $V_{OUT} = 1.2\text{V}$, Not-Switching		38		μA
		EN = 1, $V_{IN} = 3.6\text{V}$, $V_{OUT} = 1.2\text{V}$, Switching in Auto-skip mode		39		μA
		EN = 1, $V_{IN} = 3.6\text{V}$, $V_{OUT} = 1.2\text{V}$, Switching Forced-PWM, $f_{sw} = 4\text{MHz}$		12		mA
I_{SHDN}	Shutdown Supply Current	EN = 0, $T_A = 25^{\circ}\text{C}$		0.4		μA

Logic Pin Specifications

Symbol	Description	Conditions	Min	Typ	Max	Units
V_{IH}	EN Input Logic High		0.8			V
V_{IL}	EN Input Logic Low				0.3	V
I_{L_LK}	EN Input Logic Leakage	$T_A = 25^{\circ}\text{C}$, $V_I = 0\text{V}$ or V_{IN}		± 0.01		μA
R_{I_PD}	EN, MODE Input Logic Pull-Down	only connected when $V_I \leq V_{IL}$ (disconnected when $V_I \geq V_{IH}$)		250		k Ω

Thermal Shutdown Specifications

Symbol	Description	Conditions	Min	Typ	Max	Units
T_{J_SHDN}	IC Junction Thermal Shutdown	T_J rising		160		$^{\circ}\text{C}$
		Hysteresis		20		$^{\circ}\text{C}$

8. Device is guaranteed to meet performance specifications over the -40°C to $+125^{\circ}\text{C}$ operating temperature range by design, characterization and correlation with statistical process controls.

Electrical Characteristics (continued)⁹

Unless otherwise noted, the *Min and Max specs* are applied over the full Junction operation temperature range of $T_J = -40^{\circ}\text{C}$ to $+125^{\circ}\text{C}$ and $V_{IN} = 2.5\text{V}$ to 5.5V . *Typical* values are specified at $T_A = +25^{\circ}\text{C}$, $V_{IN} = 3.6\text{V}$, with $V_{OUT} = 1.2\text{V}$. $L = 330\text{nH}$, $F_{SW} = 4\text{MHz}$.

Buck Regulator Specifications

Symbol	Description	Conditions	Min	Typ	Max	Units
V _{OUT_ACC}	Output Voltage DC Accuracy	V _{OUT} = 1.2V, FPWM, T _A = -40°C to +85°C, No load	-0.75		0.75	%
		V _{OUT} = 1.2V, FPWM over line/load ¹⁰	-1.5		1.5	%
V _{OUT_LINE}	Line Regulation	V _{IN} = 2.5V to 5.5V, FPWM, V _{OUT} = 1.2V, F _{sw} = 4MHz, L = 330nH, C _{OUT} = 22μF, I _{OUT} = 2A		0.08		%/V
V _{OUT_LOAD}	Load Regulation	V _{IN} = 3.6V, FPWM, V _{OUT} = 1.2V, F _{sw} = 4MHz, L = 330nH, C _{OUT} = 22μF, I _{OUT} = 0 to 2A		0.03		%/A
V _{OUT_TRAN}	Load Transient	FPWM Mode, V _{OUT} = 1.2V, F _{sw} = 4MHz L = 330nH, C _{OUT} = 22μF, ΔI _{OUT} = 0.05A to 1.2A, Slew Rate = 1A/μs		30		mV
		Auto-skip Mode, V _{OUT} = 1.2V, F _{sw} = 4MHz L = 330nH, C _{OUT} = 22μF, ΔI _{OUT} = 0.05A to 1.2A, Slew Rate = 1A/μs		30		mV
I _{LX_VALLEY}	LX Valley Current Limit			2.9		A
I _{ZCD}	Low-Side Zero Crossing Detection Current Threshold			50		mA
I _{REV}	Low-Side Reverse Current Limiting Threshold			-1		A
R _{DS(on)_MS}	High-Side MOSFET On-Resistance			125		mΩ
R _{DS(on)_SR}	Low-Side MOSFET On-Resistance			46		mΩ
R _{LX_DIS}	LX Active Discharge Resistance			50		Ω
UV _{THR}	Output UV Trip Level	Percentage of nominal V _{OUT}		50		%

9. Device is guaranteed to meet performance specifications over $T_J = -40^{\circ}\text{C}$ to $+125^{\circ}\text{C}$ and $T_A = -40^{\circ}\text{C}$ to $+85^{\circ}\text{C}$ temperature range by design, characterization, and correlation with statistical process controls.

10. Guaranteed by design and characterization; not production tested.

Electrical Characteristics (continued)¹¹

Unless otherwise noted, the *Min and Max specs* are applied over the full Junction operation temperature range of $T_J = -40^{\circ}\text{C}$ to $+125^{\circ}\text{C}$ and $V_{IN} = 2.5\text{V}$ to 5.5V . *Typical* values are specified at $T_A = +25^{\circ}\text{C}$, $V_{IN} = 3.6\text{V}$, with $V_{OUT} = 1.2\text{V}$. $L = 330\text{nH}$, $F_{SW} = 4\text{MHz}$.

Symbol	Description	Conditions	Min	Typ	Max	Units
t_{H_OFF}	Hiccup Off Time			4		ms
t_{min_ON}	Minimum On Time			50		ns
t_{min_OFF}	Minimum Off Time	$V_{IN} = 3.4\text{V}$, $V_{OUT} = 3.3\text{V}$		65		ns
F_{SW}	Switching Frequency	KTB8316EEAA-AA, FPWM mode		1.0		MHz
		KTB8316EEAA-BD, FPWM mode		2.0		
		KTB8311EEAB-BT, FPWM mode		2.0		
		KTB8316EEAA-CJ, FPWM mode		4.0		
t_{SS_DELAY}	Soft-Start Delay Time	Time duration between EN goes High to V_{OUT} start rising		0.2		ms
t_{SS}	Soft-Start Time	Time duration between V_{OUT} start rising to 90% of V_{OUT} nominal		0.8		ms
I_{LXB_LK}	LX Pin Leakage Current	$LX = 5.5\text{V}$ or 0V , $T_A = +25^{\circ}\text{C}$		0.01		μA
		$LX = 5.5\text{V}$ or 0V , $T_A = +125^{\circ}\text{C}$		1		μA

11. Device is guaranteed to meet performance specifications over the -40°C to $+125^{\circ}\text{C}$ operating temperature range by design, characterization, and correlation with statistical process controls.

Typical Characteristics

$V_{IN} = 3.6V$, $V_{OUT} = 1.20V$, $f_{SW} = 4MHz$, $EN = High$, $MODE = GND$, $C_{OUT} = 22\mu F$, $L = 330nH$ (Murata DFE201610E-R33) and $T_A = 25^\circ C$, unless otherwise specified.

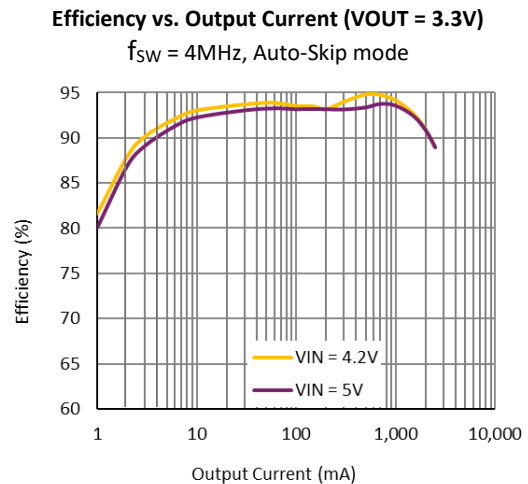
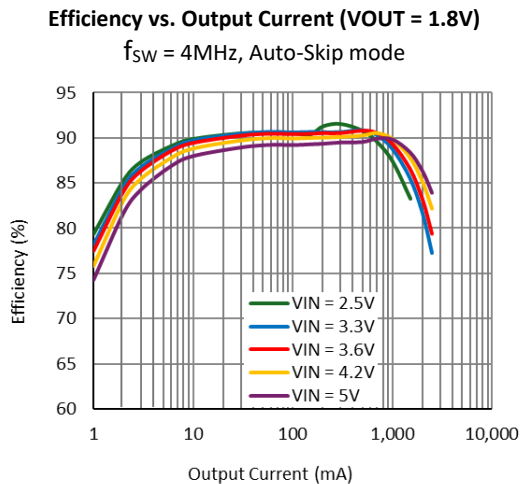
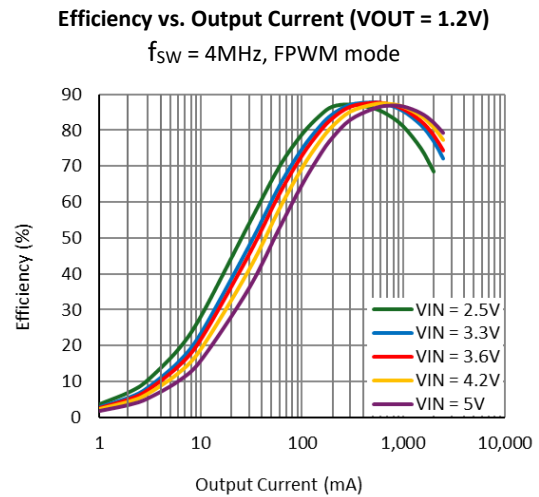
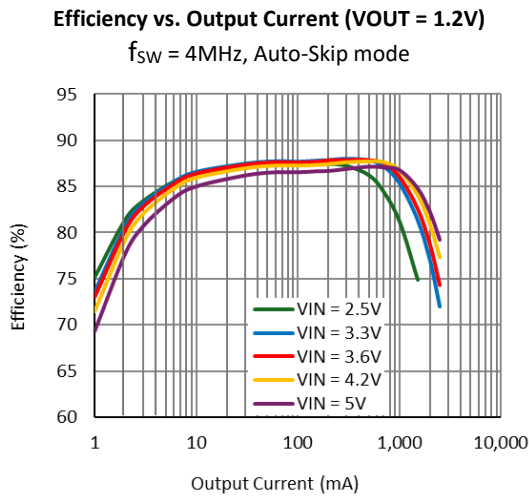
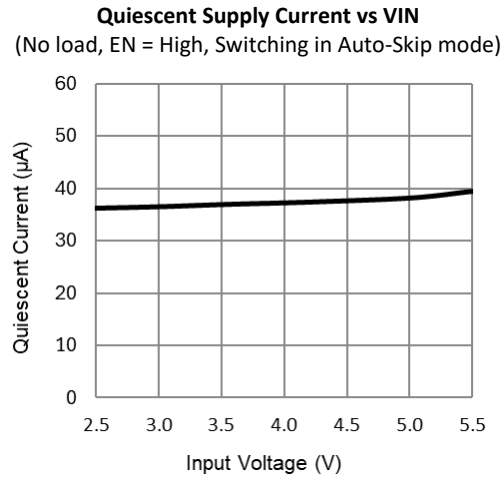
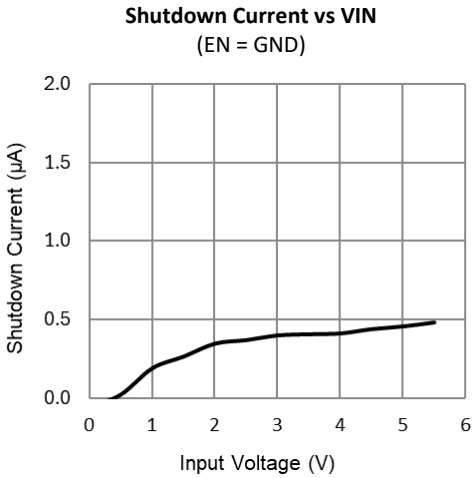

Typical Characteristics (continued)

$V_{IN} = 3.6V$, $V_{OUT} = 1.20V$, $f_{SW} = 2MHz$, EN = High, MODE = GND, $C_{OUT} = 22\mu F$, $L = 470nH$ (TDK TFM201610ALC-R47MTAA) and $T_A = 25^\circ C$, unless otherwise specified.

Efficiency vs. Output Current (VOUT = 0.9V)
 $f_{SW} = 2MHz$, Auto-Skip mode

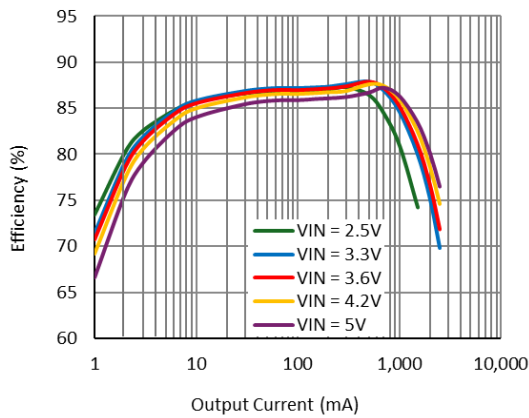

Efficiency vs. Output Current (VOUT = 1.2V)
 $f_{SW} = 2MHz$, Auto-Skip mode

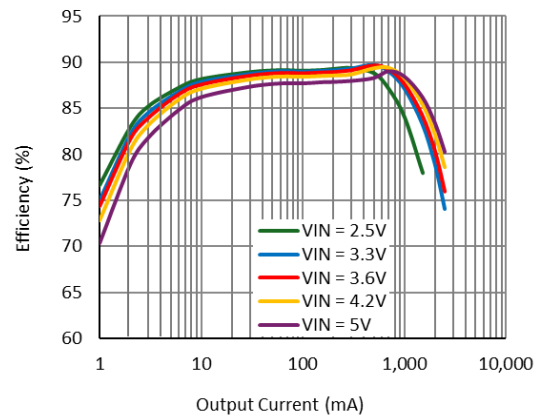

Efficiency vs. Output Current (VOUT = 1.8V)
 $f_{SW} = 2MHz$, Auto-Skip mode

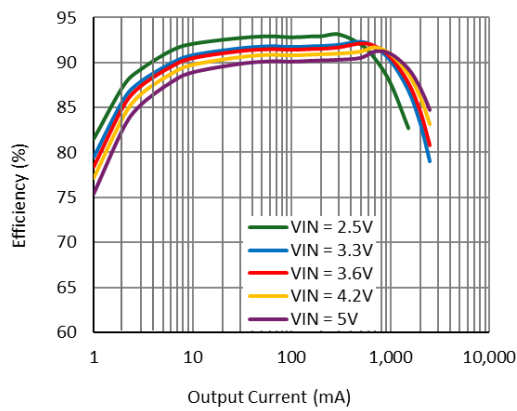

Efficiency vs. Output Current (VOUT = 1.05V)
 $f_{SW} = 2MHz$, FPWM mode

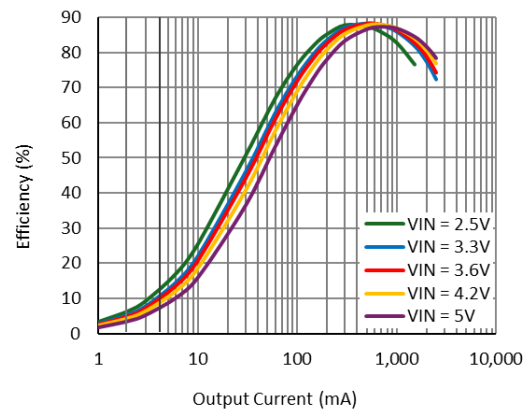

Efficiency vs. Output Current (VOUT = 0.6V)
 $f_{SW} = 1MHz$, Auto-Skip mode

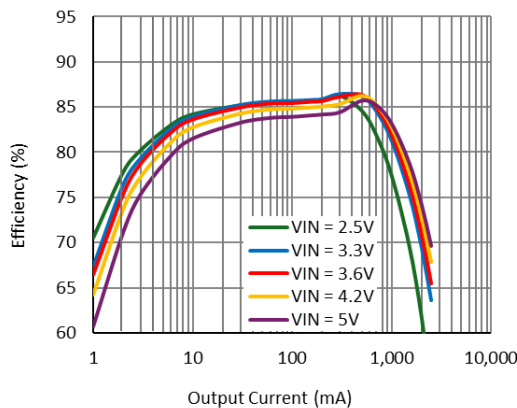

Efficiency vs. Output Current (VOUT = 1.2V)
 $f_{SW} = 1MHz$, Auto-Skip mode

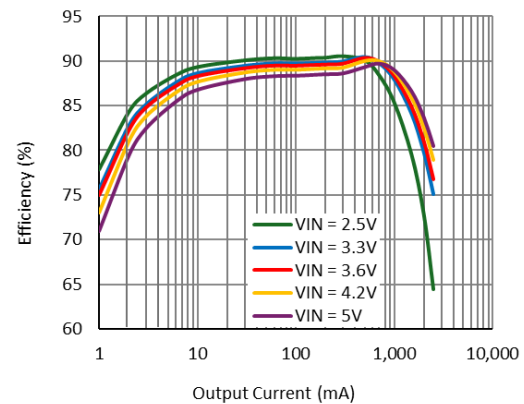

Typical Characteristics (continued)

$V_{IN} = 3.6V$, $V_{OUT} = 1.20V$, $f_{SW} = 4MHz$, EN = High, MODE = GND, $C_{OUT} = 22\mu F$, $L = 330nH$ and $T_A = 25^\circ C$, unless otherwise specified.

Load Regulation (FPWM, $V_{OUT} = 1.2V$)

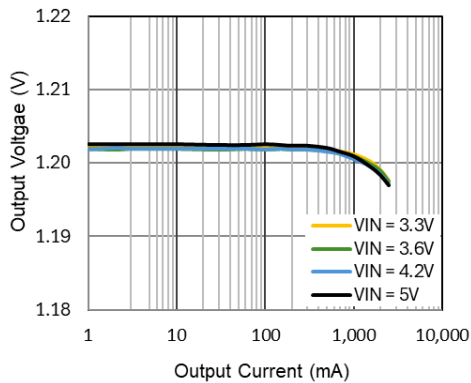

**Turn-on and off with Enable in Auto-Skip Mode
No load**

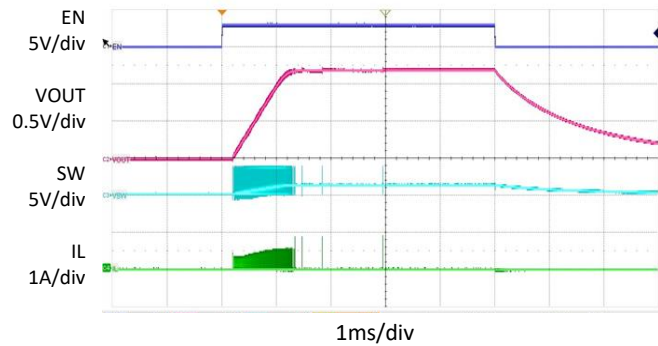

**Turn-on and off with Enable in FPWM Mode
No Load**

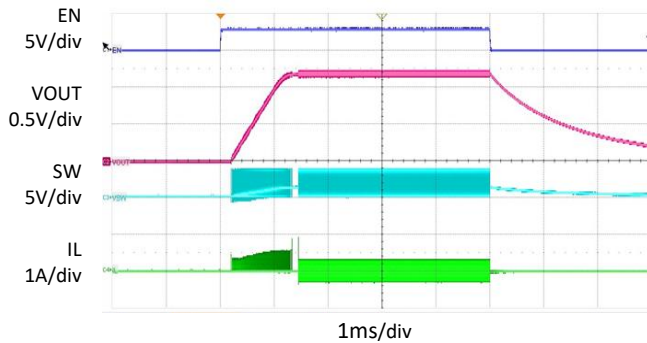

**Turn-on and off with Enable in FPWM Mode
2A Load**

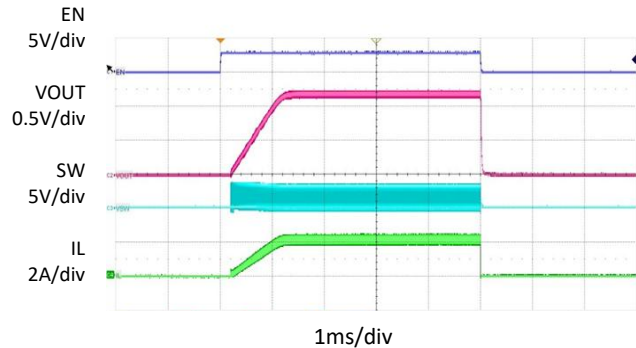

**Switching Waveform 200mA Load
in Auto-Skip ($C_{OUT} = 2 \times 22\mu F$)**

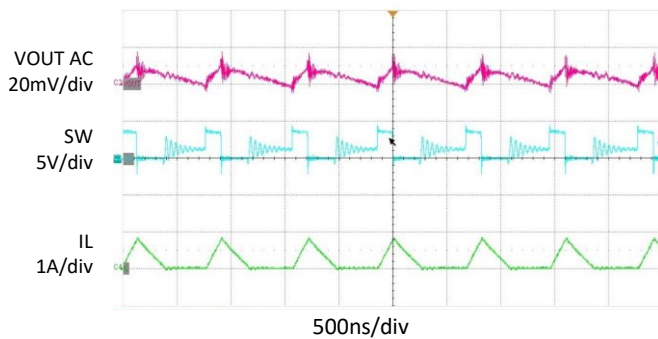

**Switching Waveform 1A Load
in Auto-Skip ($C_{OUT} = 2 \times 22\mu F$)**

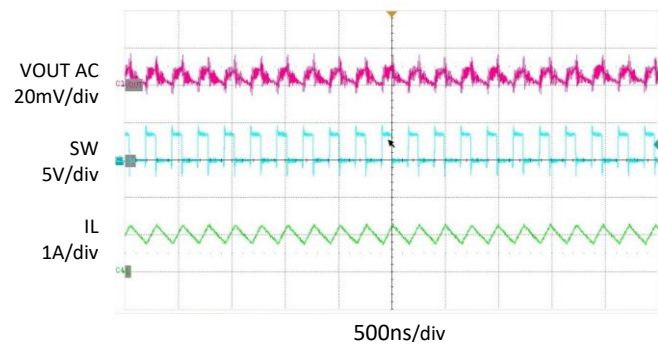

Typical Characteristics (continued)

$V_{IN} = 3.6V$, $V_{OUT} = 1.20V$, $f_{SW} = 4MHz$, $EN = High$, $MODE = GND$, $C_{OUT} = 22\mu F$, $L = 330nH$ and $T_A = 25^\circ C$, unless otherwise specified.

Switching waveform 1.8A Load
($C_{OUT} = 2 \times 22\mu F$)

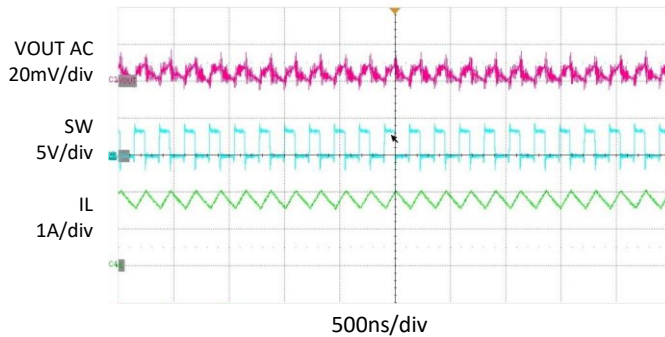

Switching waveform No Load
in FPWM ($C_{OUT} = 2 \times 22\mu F$)

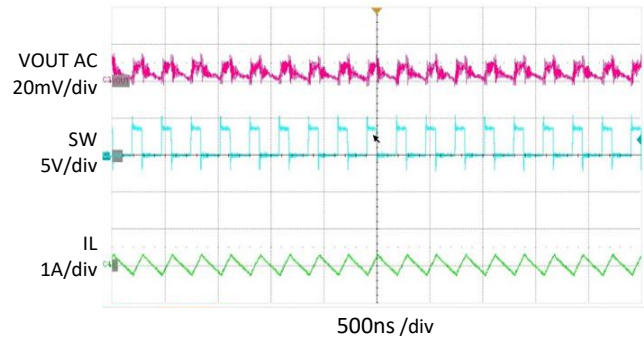

Load Step Response from 0A to 1.8A, $1A/\mu s$ SR
FPWM Mode ($C_{OUT} = 2 \times 22\mu F$)

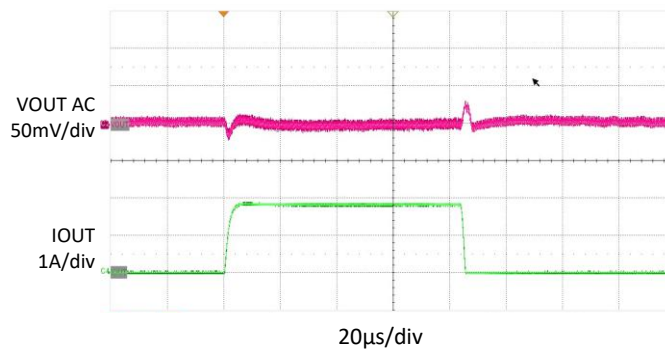

Load Step Response from 0.05A to 1.8A, $1A/\mu s$ SR
Auto-Skip Mode ($C_{OUT} = 2 \times 22\mu F$)

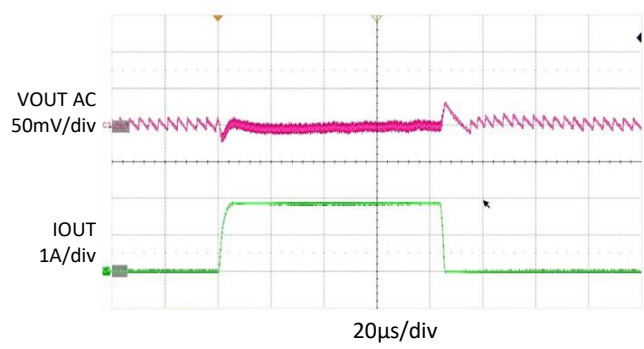

Output Short Current Limiting with Hiccup
1A Load to Output Short, $V_{OUT} = 1.2V$

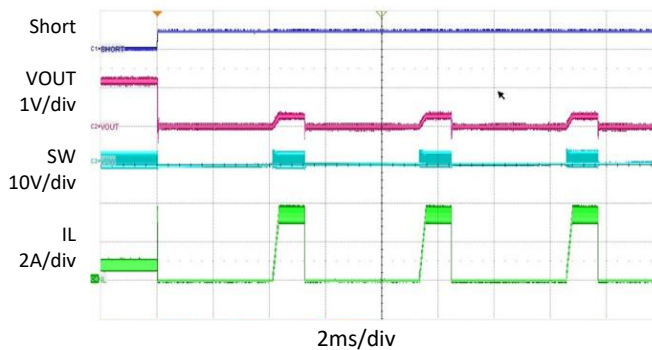

Output Short Recovery
Output Short to 1A Load, $V_{OUT} = 1.2V$

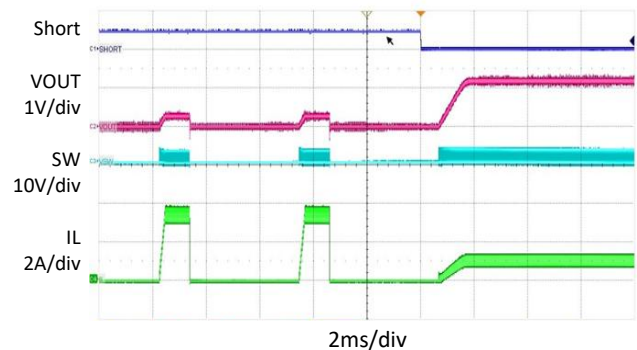

Functional Block Diagram

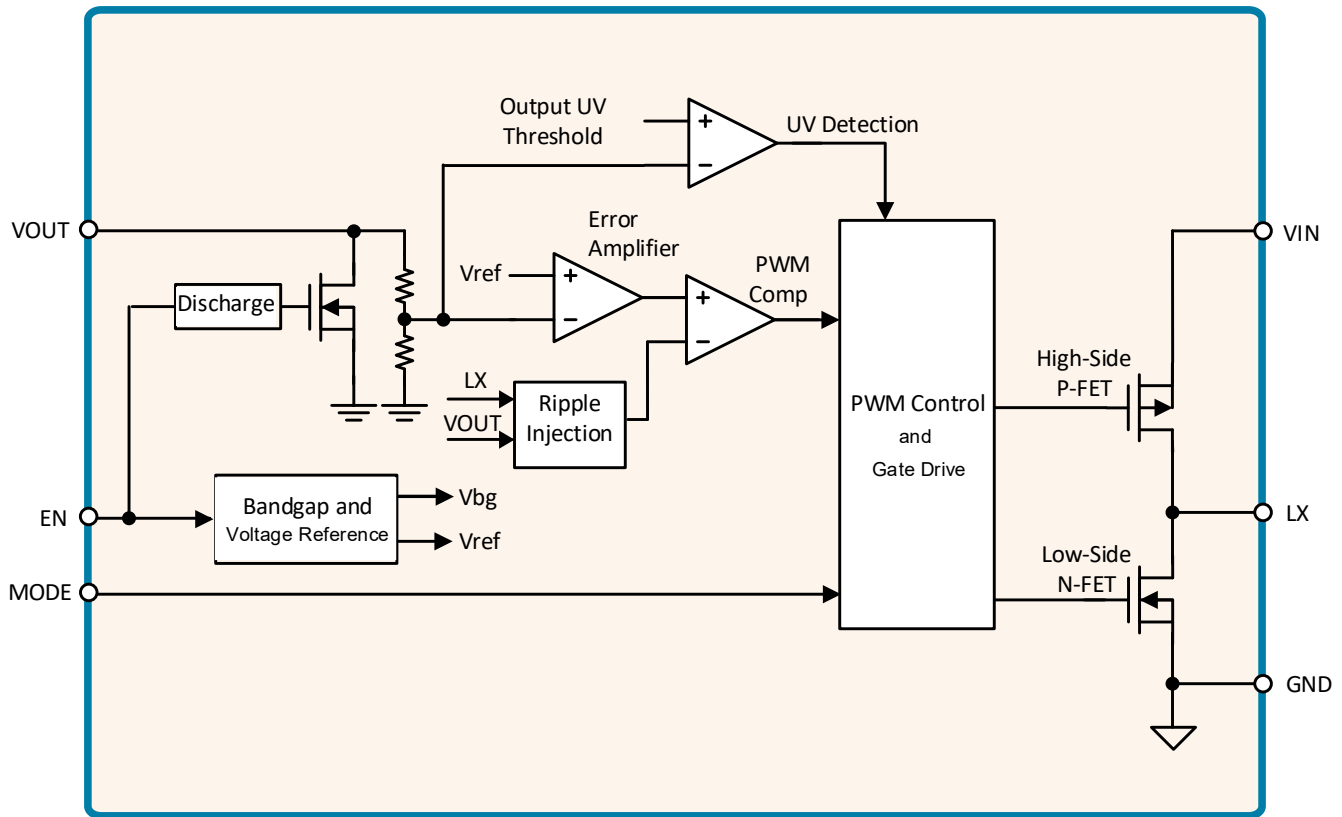

Figure 1. Functional Block Diagram

Functional Description

KTB8316/KTB8311 is a high efficiency, high-performance, monolithic voltage step-down (buck) regulator that operates from an input voltage range of 2.5V to 5.5V and can support output load current levels up to 2.5A. The device integrates the main power MOSFET switch, synchronous rectifier switch, PWM control circuitry, and various over current and temperature protection features.

Control Scheme

KTB8316/KTB8311 uses a proprietary adaptive on-time (AOT) PWM control scheme. Compared to typical current-mode PWM schemes, the AOT control scheme provides quick response to line and load transients with excellent stability and wide bandwidth, thereby minimizing output voltage droop or overshoot to support dynamic loads with minimal output capacitance. The adaptive on-time control eliminates the delay for the next switching clock cycle to increase response to load transient events.

KTB8316/KTB8311 feedback loop also adds a proprietary, internally compensated, integrating error amplifier to remove the output voltage offset normally associated with other AOT, constant on-time (COT), and hysteretic architectures.

Shutdown Mode

When the EN pin is low, KTB8316/KTB8311 is in shutdown mode and draws extremely low supply current.

Output Voltage Setting

The output voltage is adjusted and set by an external resistor (R_{SET}) connected between the MODE pin and GND. The tables below show the recommended voltage settings for the different switching frequency options.

The external R_{SET} resistor is identified during the device power-up or when EN pin goes from low to high. The R_{SET} value should not be changed during normal operation.

Table 1. MODE Pin Resistor Settings for KTB8316EEAA-AA 1MHz

Setting Code	Mode R_{SET} (k Ω)	V_{OUT} Setting (V)	Auto-skip / FPWM Mode
Short to GND	0	0.6 (Default)	Auto-skip
2	4.7	0.3	Auto-skip
3	6.8		FPWM
4	8.25	0.4	Auto-skip
5	10		FPWM
6	12	0.45	Auto-skip
7	14		FPWM
8	16.9	0.5	Auto-skip
9	19.6		FPWM
10	22.6	0.9	Auto-skip
11	26.1		FPWM
12	30	1.65	Auto-skip
13	34.8		FPWM
Short to VIN	Short to VIN	0.6 (Default)	FPWM

Table 2. MODE Pin Resistor Settings for KTB8316EEAA-BD 2MHz

Setting Code	Mode R_{SET} (k Ω)	V_{OUT} Setting (V)	Auto-skip / FPWM Mode
Short to GND	0	1.2 (Default)	Auto-skip
2	4.7	0.6	Auto-skip
3	6.8		FPWM
4	8.25	0.8	Auto-skip
5	10		FPWM
6	12	0.9	Auto-skip
7	14		FPWM
8	16.9	1	Auto-skip
9	19.6		FPWM
10	22.6	1.8	Auto-skip
11	26.1		FPWM
Short to VIN	Short to VIN	1.2 (Default)	FPWM

Table 3. MODE Pin Resistor Settings for KTB8311EEAB-BT 2MHz

Setting Code	Mode R _{SET} (kΩ)	V _{OUT} Setting (V)	Auto-skip / FPWM Mode
Short to GND	0	2.2 (Default)	Auto-skip
2	4.7	0.5	FPWM
3	6.8	0.6	FPWM
4	8.25	0.75	FPWM
5	10	0.85	FPWM
6	12	0.9	FPWM
7	14	1.05	FPWM
8	16.9	1.1	FPWM
9	19.6	1.2	FPWM
10	22.6	1.8	Auto-skip
11	26.1		FPWM
12	30	3.3	Auto-skip
13	34.8		FPWM
Short to VIN	Short to VIN	2.2 (Default)	FPWM

Table 4. MODE Pin Resistor Settings for KTB8316EEAA-CJ 4MHz

Setting Code	Mode R _{SET} (kΩ)	V _{OUT} Setting (V)	Auto-skip / FPWM Mode
Short to GND	0	1.2 (Default)	Auto-skip
6	12	0.9	Auto-skip
7	14		FPWM
8	16.9	1	Auto-skip
9	19.6		FPWM
10	22.6	1.8	Auto-skip
11	26.1		FPWM
12	30	3.3	Auto-skip
13	34.8		FPWM
Short to VIN	Short to VIN	1.2 (Default)	FPWM

Enable

KTB8316/KTB8311 buck regulator is turned on and off using the active high Enable (EN) pin. Pull the EN pin to a logic high level to enable the buck regulator, or to a logic low level to disable the device.

Soft-Start

KTB8316/KTB8311 contains soft-start circuitry to ramp up V_{OUT} slowly in order to reduce inrush current to V_{IN} and prevent the inductor current from reaching the current limit during startup. After the EN pin is toggled from a Low to High state, the buck regulator soft-start is initiated after a Soft Start delay (t_{SS_DELAY}) of 0.2ms. During soft-start, the ramp up rate of the output voltage V_{OUT} is controlled to increase linearly until it reaches regulation during an internally fixed soft start time (t_{SS}).

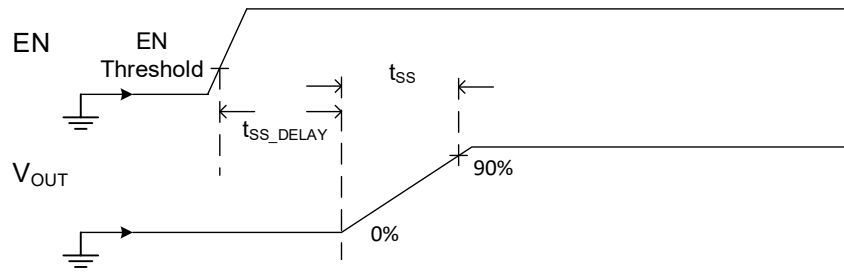

Figure 2. Power-up Timing Diagram

Auto-Skip Mode and Forced-PWM

KTB8316/KTB8311 can operate either in Automatic Skip (Auto-skip) mode or Forced-PWM (FPWM) depending on the state of the MODE input pin. The MODE pin must be set to a logic low or to a fixed resistor (R_{SET}) setting, please refer to Tables 1-4 for resistor value selection.

In Auto-skip mode, KTB8316/KTB8311 transitions automatically between constant frequency PWM operation at heavy loads and PFM mode under light load conditions. Auto-skip mode is helpful for applications that need high efficiency at light loads. While skipping, single pulses are evenly spaced, resulting in the lowest output ripple and noise when compared to competing “pulse-grouping” or “burst mode” devices.

In noise-sensitive applications, even under light load conditions, fixed switching frequency can be desired to minimize EMI and conducted interference in circuit operation. The KTB8316/KTB8311 is set to operate in forced-PWM (FPWM) mode by terminating MODE pin as outlined in Tables 1-4.

Active Output Discharge

KTB8316/KTB8311 has an Active Output Discharge feature where a 50Ω (typical) on-chip pull-down resistor is connected between VOUT and GND pins. This internal resistor discharges the output capacitor once the device is disabled (EN pin Low), or $V_{IN} < V_{UVLO}$ or $V_{IN} > V_{OVP}$, or in thermal shutdown.

Input Under-Voltage Lockout (UVLO)

When the input voltage (V_{IN}) falls below the under-voltage lockout threshold (V_{UVLO}), the buck is disabled. When V_{IN} rises above V_{UVLO} , and if the buck is enabled, the default soft-start ramp begins, and the regulator will resume operation.

Current Limit Protection (CLP)

The high-side switch peak-current limit and low-side switch valley-current limit protect the integrated FETs and inductor during over-current faults. The current limit controls the buck switching on a cycle-by-cycle basis and has a higher priority than the regulation threshold and adaptive on-time.

Every cycle when high-side FET turns on, after the minimum On-time of 50ns, the device monitors Peak current limit. If the current limit is reached, the high-side FET turns off immediately and the low-side FET turns on. The low side remains on until the inductor current goes below the Valley current limit. Every cycle, the device ensures that the inductor current is lower than the Valley current limit before the high-side is turned on.

Output Short-Circuit Protection

During normal operation or soft-start, if an over-current event occurs and the device hits the current limit consecutively for 256 cycles or the output voltage droops by 50% of regulation then KTB8316/KTB8311 will

enter hiccup mode and pause all switching. The buck regulator attempts to soft-start after a Hiccup Off Time t_{H_OFF} of about 4ms. If the output short persists, the buck regulator once again enters Hiccup mode and the cycle repeats until the short is removed. The low duty-factor during Hiccup mode prevents the IC from over-heating.

Output Overvoltage Protection

In Auto-skip mode, if VOUT output is forced externally over the regulation voltage, the device stops switching.

In Forced-PWM mode, if the output is raised externally above the regulation level, the device continues switching and pulls-down the output with the negative inductor current as low as the Low-Side Reverse Current Limiting Threshold I_{REV} .

Thermal Shutdown

KTB8316/KTB8311 is turned off by an internal thermal shutdown when the junction temperature exceeds the thermal shutdown threshold (160°C typical). The device restarts when the junction temperature drops by 20°C.

Recommended Inductor

Inductor selection affects the steady-state operation as well as transient behavior and loop stability of the buck regulator circuit. The three most important inductor specifications to consider are inductor value, DC resistance (DCR), and saturation current rating. Higher inductance values give lower inductor current ripple, while lower inductance usually gives faster load transient response. Select an inductor with a saturation current rating that is higher than KTB8316 peak inductor current. The peak inductor current corresponds to the Valley current limit plus the peak-to-peak current ripple of 1A. The peak inductor current is 4A.

Also, choose an inductor with sufficient temperature-rise current rating to satisfy the RMS load-current of the application. Consider the inductor resistance as it affects efficiency. Larger physical case-sizes, good winding designs, and better magnetic materials can increase efficiency.

For the recommended inductors, please refer to the Component Selection section.

Recommended Capacitors

Ceramic input and output capacitors with X5R or X7R dielectric are recommended due to their low ESR, low ESL, low temperature coefficients, and small physical sizes. Consider the voltage rating, size, and DC bias derating characteristic of the capacitor based on application circuit requirements.

Input Capacitor

A total input capacitance of 20 μ F or more is recommended on the input supply pin (VIN) to ground (GND). Choose an input capacitor with voltage rating greater than the maximum input voltage, for example of 10V or more. Larger values and larger case-size provide more effective capacitance when considering the DC bias derating characteristic of the capacitor. If the application input voltage is supplied through a connector or a cable, an additional input bypass capacitor should be added where V_{IN} first arrives to the PCB.

Output Capacitors

Choose output capacitors with voltage rating of 10V or more, 22 μ F total nominal capacitance or more. Consider the V_{OUT} setting of the regulator and how case size has a significant impact on the capacitor DC bias derating. At high V_{OUT} settings, more capacitance is needed to achieve the same effective capacitance compared to lower V_{OUT} settings.

Applications Information

The typical application schematic in the figure below is configured for 1.2V output, 4.0MHz switching frequency, and supporting a load up to 2.5A.

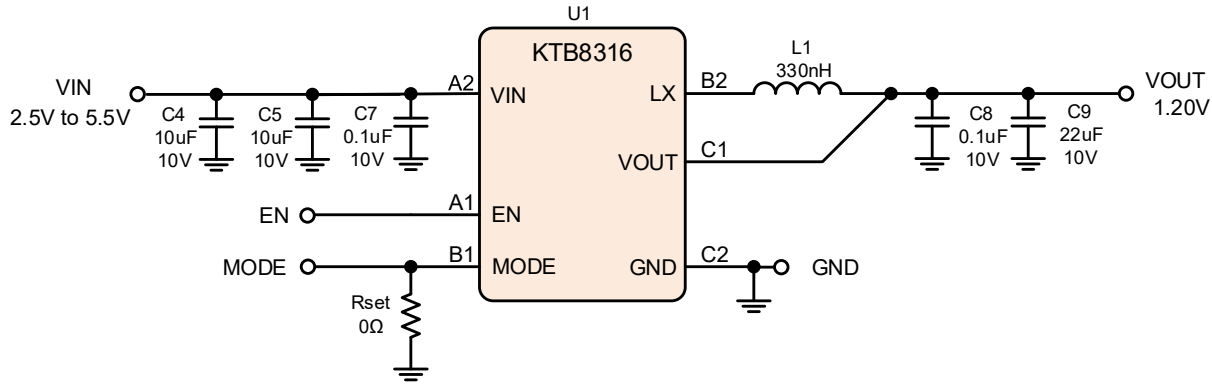

Figure 3. Typical Application Schematic

Component Selection

Depending on the switching frequency preference 1, 2 or 4MHz, the recommended component selections are listed below.

Component List for KTB8316EEAA-AA 1MHz

VOUT output voltage range from 0.3V to 1.65V

QTY	Designator	Description	Manufacturer	Part Number
1	U1	2.5A, 1MHz Synchronous Buck regulator	Kinetic Technologies	KTB8316EEAA-AA
1	L1	Inductor 1µH 4.2A 37mΩ SMD	Abracon	AOTA-B201610S1R0MT
2	C4, C5	Ceramic capacitor 10µF 10V X5R 0603	Samsung	CL10A106MP8NNNC
2	C7, C8	Ceramic capacitor 0.1µF 10V X5R 0402	Samsung	CL05A105KP5NNNC
1	C9	Ceramic capacitor 22µF 10V X5R 0603	Samsung	
1	RSET	Please refer to Table 1 for RSET options		

Component List for KTB8316EEAA-BD 2MHz

VOUT output voltage range from 0.6V to 1.8V

QTY	Designator	Description	Manufacturer	Part Number
1	U1	2.5A, 2MHz Synchronous Buck regulator	Kinetic Technologies	KTB8316EEAA-BD
1	L1	Inductor 470nH 5.2A 25mΩ SMD	TDK	TFM201610ALC-R47MTAA
2	C4, C5	Ceramic capacitor 10µF 10V X5R 0603	Samsung	CL10A106MP8NNNC
2	C7, C8	Ceramic capacitor 0.1µF 10V X5R 0402	Samsung	CL05A105KP5NNNC
1	C9	Ceramic capacitor 22µF 10V X5R 0603	Samsung	
1	RSET	Please refer to Table 2 for RSET options		

Component List for KTB8311EEAB-BT 2MHz

VO_{UT} output voltage range from 0.5V to 3.3V

QTY	Designator	Description	Manufacturer	Part Number
1	U1	2.5A, 2MHz Synchronous Buck regulator	Kinetic Technologies	KTB8311EEAB-BT
1	L1	Inductor 470nH 5.2A 25mΩ SMD	TDK	TFM201610ALC-R47MTAA
2	C4, C5	Ceramic capacitor 10μF 10V X5R 0603	Samsung	CL10A106MP8NNNC
2	C7, C8	Ceramic capacitor 0.1μF 10V X5R 0402	Samsung	CL05A105KP5NNNC
1	C9	Ceramic capacitor 22μF 10V X5R 0603	Samsung	
1	R _{SET}	Please refer to Table 3 for R _{SET} options		

Component List for KTB8316EEAA-CJ 4MHz

VO_{UT} output voltage range from 0.9V to 3.3V

QTY	Designator	Description	Manufacturer	Part Number
1	U1	2.5A, 4MHz Synchronous Buck regulator	Kinetic Technologies	KTB8316EEAA-CJ
1	L1	Inductor 330nH 4A 26mΩ SMD	Murata	DFE201610E-R33M=P2
2	C4, C5	Ceramic capacitor 10μF 10V X5R 0603	Samsung	CL10A106MP8NNNC
2	C7, C8	Ceramic capacitor 0.1μF 10V X5R 0402	Samsung	CL05A105KP5NNNC
1	C9	Ceramic capacitor 22μF 10V X5R 0603	Samsung	
1	R _{SET}	Please refer to Table 4 for R _{SET} options		

Recommended PCB Layout

Good PCB thermal design is critical to support heavy load currents and keep efficiency high. In order to dissipate heat from the buck regulator IC and the inductor, large copper areas can be used to spread the heat away from these components.

The KTB8316/KTB8311 evaluation board is designed with a similar layout as the Recommended PCB Layout figure.

High current switching traces between the device, the inductor and the input and output bypass capacitors should be kept short in order to minimize parasitic resistance and power losses.

Place the input bypass capacitors as close as possible to the device. Place the output capacitors close to the inductor.

Route a Kelvin sense trace from the inductor VOUT side to the IC VOUT pin.

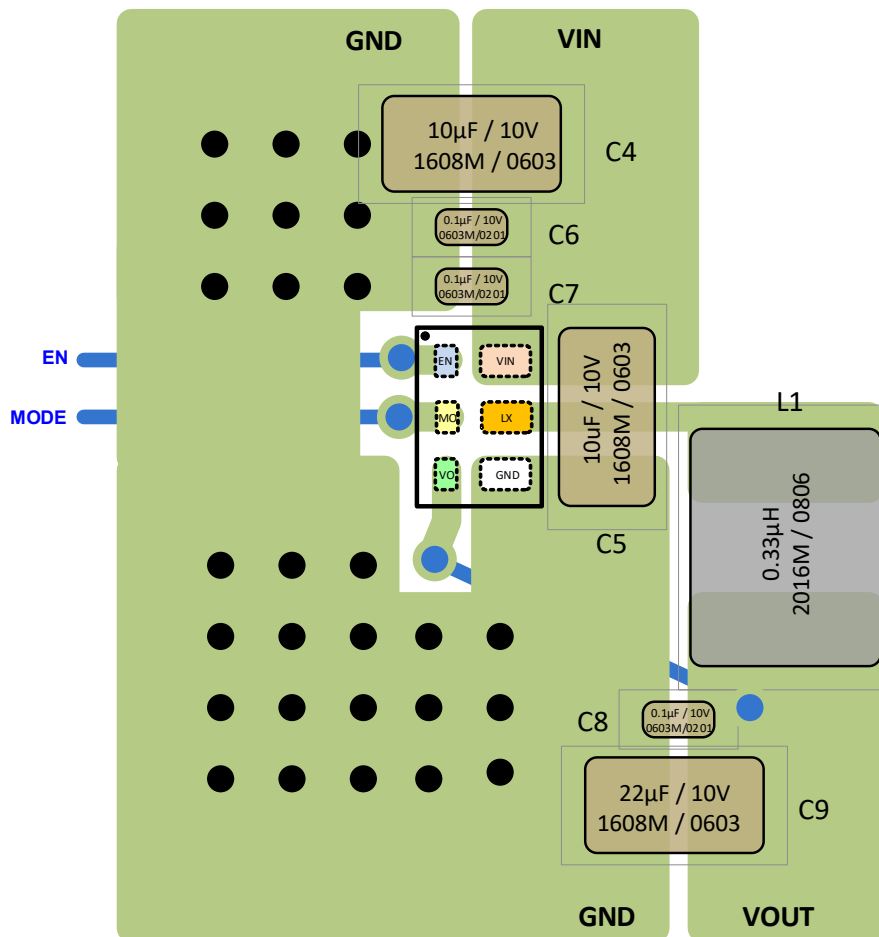
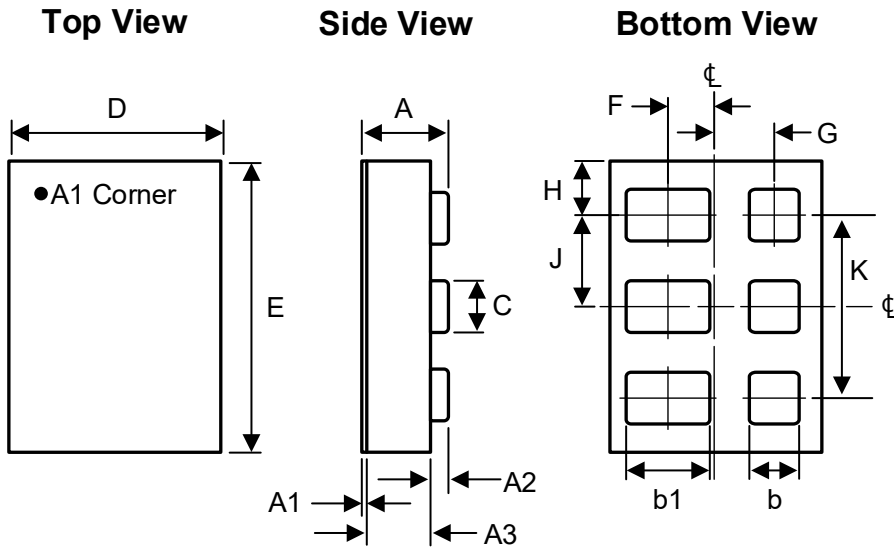

Figure 4. Recommended PCB Layout

Packaging Information

KTB8316EAA
 HP-WLCSP-6 (1.064mm x 1.464mm x 0.460mm)



Dimension	mm		
	Min.	Typ.	Max.
A	0.429	0.460	0.491
A1	0.023	0.025	0.027
A2	0.076	0.090	0.104
A3	0.330	0.345	0.360
b	0.182	0.187	0.192
b1	0.415	0.420	0.425
C	0.255	0.260	0.265
D	1.014	1.064	1.114
E	1.414	1.464	1.514
F	0.2171		
G	0.2813		
H	0.2880		
J	0.444		
K	0.888		
M	0.365		
N	0.525		
P	0.292		

Recommended Footprint

(NSMD Pad Type)

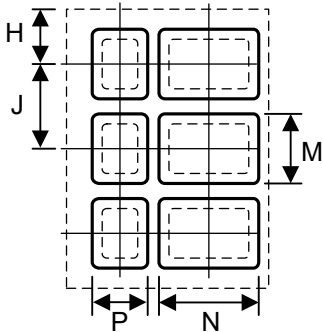

Packaging Information (continued)

KTB8311EAB
 HP-WLCSP-6 (1.064mm x 1.464mm x 0.460mm)

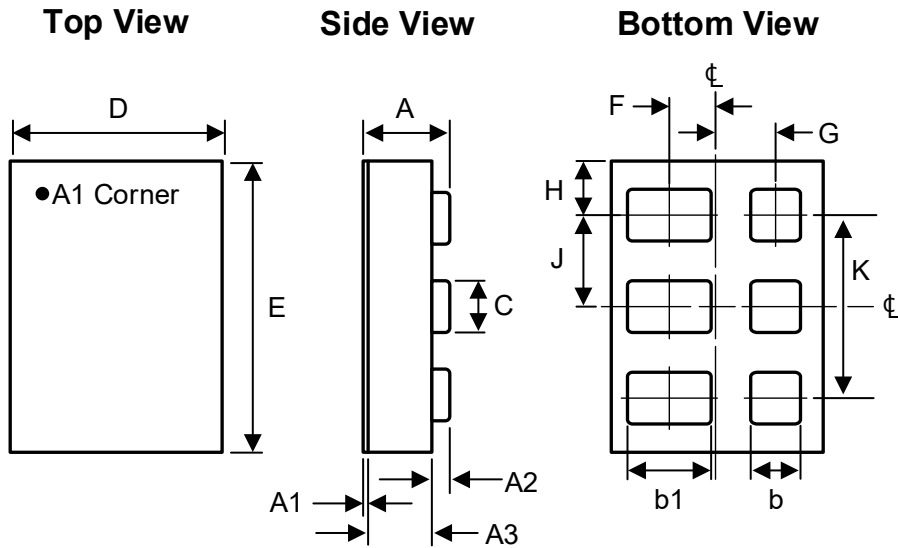

Dimension	mm		
	Min.	Typ.	Max.
A	0.429	0.460	0.491
A1	0.023	0.025	0.027
A2	0.076	0.090	0.104
A3	0.330	0.345	0.360
b	0.245	0.250	0.255
b1	0.415	0.420	0.425
C	0.255	0.260	0.265
D	1.014	1.064	1.114
E	1.414	1.464	1.514
F	0.225		
G	0.310		
H	0.272		
J	0.460		
K	0.920		
M	0.365		
N	0.525		
P	0.355		

Recommended Footprint

(NSMD Pad Type)

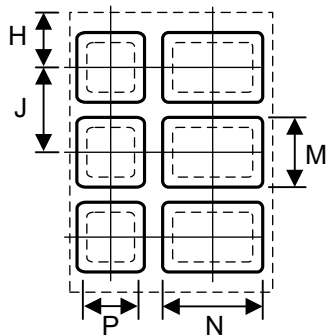

Packing Material Information

Reel Dimensions

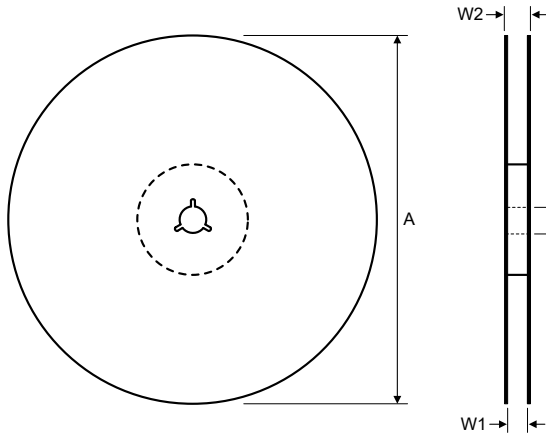

Dimension	mm		
	Min.	Typ.	Max.
A	178	180	180
C	12.8	13.0	13.5
W1	8.4	8.4	9.9
W2	—	—	14.4

DWG-0260-01

Carrier Tape Dimensions

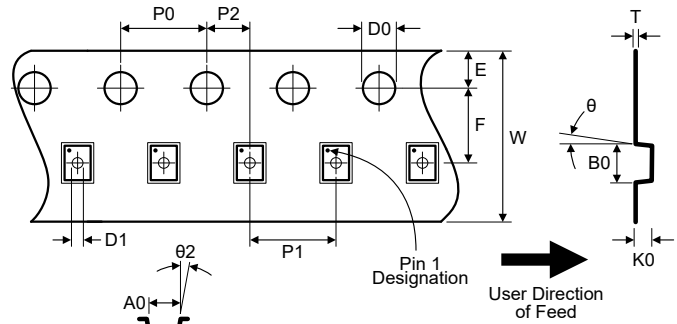

Dimension	mm		
	Min.	Typ.	Max.
A0	1.164	1.214	1.264
B0	1.564	1.614	1.664
K0	0.56	0.61	0.66
P0	3.90	4.00	4.10
P1	3.90	4.00	4.10
P2	1.95	2.00	2.05
D0	1.50	1.55	1.60
D1	0.45	0.50	0.55
E	1.65	1.75	1.85
F	3.45	3.50	3.55
10P0	39.8	40.0	40.2
W	7.90	8.00	8.30
T	0.18	0.20	0.22
θ	0°		5°
θ2	0°		5°

DWG-0274

Cover Tape Dimensions

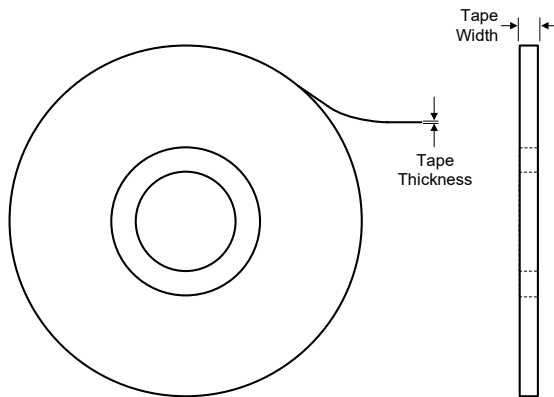

Dimensions	Dimension	mm		
		Min.	Typ.	Max.
	Tape Thickness	0.04	0.05	0.06
8mm	Tape Width	5.2	—	5.5

DWG-0259-01

Kinetic Technologies cannot assume responsibility for use of any circuitry other than circuitry entirely embodied in a Kinetic Technologies product. No intellectual property or circuit patent licenses are implied. Kinetic Technologies reserves the right to change the circuitry and specifications without notice at any time.