

## Integrated Dual MOSFET Bridge Rectifier for Power over Ethernet

### Features

- Fully supports IEEE® Std. 802.3bt Interface
- Compatible with both IEEE® Std. 802.3af/at
- Supports Input Power Levels Up to 90W
- Integrated Active Bridge Rectifier
- Integrated Solution Optimizing Board Space/Size
- High Efficiency Solution with Synchronous Rectification
- Halogen Free and RoHS Compliant
- Low Forward Voltage Drop Using Power FET
- Small 8-Pin WDFN44-8 Package
- -40°C to 125°C Operating Junction Temperature Range

### Applications

- Integrated bridge rectifier and interface for PoE Pan, tilt and zoom (PTZ), security and web cameras
- Voice over IP (VoIP) phones
- Wireless LAN access points
- WiMAX terminals
- Point-of-sale (POS) terminals
- RFID terminals
- Thin clients and notebook computers
- Fiber-to-the-home (FTTH) terminals

### Brief Description

The KTA1170 is a single-chip, highly integrated solution for voltage rectification on Power over Ethernet (PoE) Powered Devices. Applications include Voice over IP (VoIP) Phones, Wireless LAN Access Point, Security Cameras, WiMAX Terminals, Point-of-Sales Terminals, RFID Readers, Thin Clients and Notebook computers.

The KTA1170 is a dual ideal diode bridge designed to rectify independent DC channels into a single output. The KTA1170 can sense the input channels from |IN1-IN2| or |IN3-IN4| separately and connects them to the output with the correct polarity. KTA1170 can also sense the input channels from |IN1-IN2| and |IN3-IN4| together and connects them to the output with the correct polarity. A very common application is an IEEE 802.3af/at/bt-compliant powered device, which is powered by standards compliant PSE (Power Sourcing Equipment). However, in some applications, where the power is sourced from a non-compliant PSE, refer to [Application Note AN167](#) for additional guidelines on designing with KTA1170.

### Typical Application

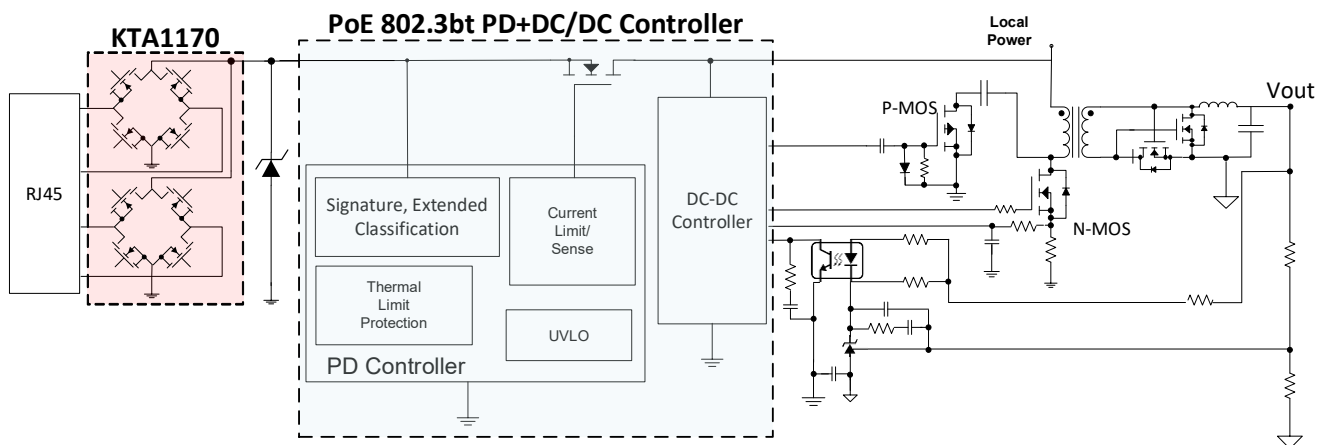

## Ordering Information

Part Number	Marking <sup>1</sup>	Operating Junction Temperature	Package
KTA1170GVAE-TB	TSYWZ aaaaaaa	-40°C to +125°C	WDFN44-8

## Pinout Diagram

WDFN44-8 (4.00mmx 4.00mm x 0.75mm)

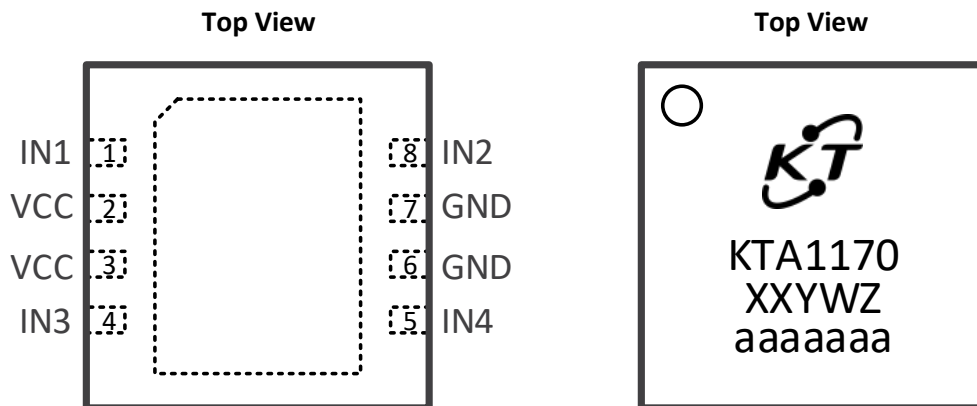

8-Pin 4.00mm x 4.00mm x 0.75mm  
WDFN Package

### Top Mark

XX = Device Code, YW = Date Code, Z = Serial Number  
aaaaaaa = Assembly Lot Tracking Number

## Pin Descriptions

Pin #	Name	Function
1	IN1	First Input power pin (AC) for the first bridge rectifier
2, 3	VCC	Output DC power pin
4	IN3	First Input power pin (AC) for the second bridge rectifier
5	IN4	Second Input power pin (AC) for the second bridge rectifier
6, 7	GND	Must be connected to power ground
8	IN2	Second Input power pin (AC) for the first bridge rectifier
-	EP	Exposed Pad; Connected to GND

1. TS = Device Code, YW = Date Code, Z = Serial Number, aaaaaa = Assembly Lot Tracking Number.

## Absolute Maximum Ratings<sup>2</sup>

Unless otherwise noted,  $T_A = +25^\circ\text{C}$ .

Symbol	Description	Value	Units
IN1, IN2, IN3, IN4, VCC	High Voltage Pins <sup>3</sup>	2.7 to 80	V
$V_{DS}$	Drain to Source Voltage (Single FET)	80	V
$I_D$	Drain Current – continuous (Single FET)	3	A
	Drain Current – pulse, duty = 10 $\mu$ s/Period = 1s (Single FET)	43	
$T_S$	Storage Temperature	-55 to 150	$^\circ\text{C}$
$T_J$	Junction Operating Temperature	-40 to 150	$^\circ\text{C}$
$T_S$	Soldering Temperature	260	$^\circ\text{C}$

## ESD Ratings

Symbol	Description	Value	Units
$V_{ESD\_HBM}$	JESD22-A114 Human Body Model (HBM) <sup>4</sup>	2	kV
$V_{ESD\_CD}$	IEC 61000-4-2 Contact Discharge <sup>5</sup>	8	kV
$V_{ESD\_AGD}$	IEC 61000-4-2 Air-Gap Discharge <sup>5</sup>	15	kV

## Thermal Capabilities<sup>6</sup>

Symbol	Description	Value	Units
$\theta_{JA}$	Thermal Resistance – Junction to Ambient	31.45	$^\circ\text{C}/\text{W}$
$P_D$	Maximum Power Dissipation	3.97	W
$\Delta P_D/\Delta T$	Derating Factor Above $T_A = 25^\circ\text{C}$	-31.8	mW/ $^\circ\text{C}$

## Recommended Operating Conditions

Symbol	Description	Min.	Typ. <sup>7</sup>	Max.	Units
$V_{IN1}, V_{IN2}, V_{IN3}, V_{IN4}$	Input Power Supply		48	57	V
$V_{IN1}-V_{IN2}, V_{IN3}-V_{IN4}$	Input Capacitance between pins		225	300	pF
$T_A$	Ambient Operating Temperature Range	-40	-	+85	$^\circ\text{C}$
$T_{J\_MAX}$	Recommended Maximum Junction Operating Temperature	-40	-	+125	$^\circ\text{C}$

- Stresses above those listed in Absolute Maximum Ratings may cause permanent damage to the device. Functional operation at conditions other than the operating conditions specified is not implied. Only one Absolute Maximum rating should be applied at any one time.
- Steady state or transient conditions like system start-up and other noise conditions. Device must not be exposed to sustained over-voltage condition at this level. See section on Rectification and Protection for further details on Integrated Surge Protection.
- Human Body Model and Charged Device Model ESD limits are specified at the chip level.
- Air Discharge, and Contact Discharge are specified at the system level.
- Junction to Ambient thermal resistance is highly dependent on PCB layout. Values are based on thermal properties of the device when soldered to an EV board.
- Typical specification, not 100% tested. Performance guaranteed by design and/or other correlation methods.

## Electrical Characteristics

Unless otherwise noted, specifications are for  $T_J = -40^{\circ}\text{C}$  to  $+125^{\circ}\text{C}$ . Typical specifications are for  $T_J = +25^{\circ}\text{C}$  and  $V_{IN} = 48\text{V}$  (at RJ45 Input). Typical specifications not 100% tested.

### PD (all PD voltage limits specified at the RJ45 Interface) Specifications

Symbol	Description	Conditions	Min	Typ	Max	Units
$V_{IN}(\text{min})$	Minimum Input Voltage Range		37	38	42	V
$I_{INRUSH\_AF}$	Inrush Current Limit (AF) – Type 1 PD <sup>8</sup>	For $V_{OUT} \leq 16\text{V}$ during startup, Total equivalent $C_{IN} = 5\mu\text{F}$	50	160	240	mA
$I_{INRUSH\_AT}$	Inrush Current Limit (AT) – Type 2 PD <sup>8</sup>	For $V_{OUT} \leq 16\text{V}$ during startup, Total equivalent $C_{IN} = 5\mu\text{F}$	210	320	400	mA
$I_{INRUSH\_BT1}$	Inrush Current Limit (BT) – Type 3 PD <sup>8</sup>	For $V_{OUT} \leq 16\text{V}$ during startup, Total equivalent $C_{IN} = 10\mu\text{F}$ (SINGLE-SIGNATURE)	300	410	500	mA
$I_{INRUSH\_BT2}$	Inrush Current Limit (BT) – Type 4 PD <sup>8</sup>	For $V_{OUT} \leq 16\text{V}$ during startup, Total equivalent $C_{IN} = 20\mu\text{F}$ (SINGLE-SIGNATURE)	380	500	600	mA
$I_{IN\_AF}$	Operating Current – Type 1 <sup>8</sup>	Device configured for 13W operation			450	mA
$I_{IN\_AT}$	Operating Current – Type 2 <sup>8</sup>	Device configured for 30W operation			800	mA
$I_{IN\_BT1}$	Operating Current – Type 3 <sup>8</sup>	Device configured for 60W operation			1500	mA
$I_{IN\_BT2}$	Operating Current – Type 4 <sup>8</sup>	Device configured for 90W operation			2300	mA
$I_{LIM\_AF}$	PoE Current Limit – Type 1 <sup>8</sup>	Device configured for 13W operation	450	600		mA
$I_{LIM\_AT}$	PoE Current Limit – Type 2 <sup>8</sup>	Device configured for 30W operation	800	1000		mA
$I_{LIM\_BT1}$	PoE Current Limit – Type 3 <sup>8</sup>	Device configured for 60W operation	1500	1800		mA
$I_{LIM\_BT2}$	PoE Current Limit – Type 4 <sup>8</sup>	Device configured for 90W operation	2300	2700		mA
$R_{DS-ON}$	Rectifier FET On Resistance	$I_{IN} = 1\text{A}$ per active bridge (Totally 2A), $T_A = 25^{\circ}\text{C}$		0.25	0.3	$\Omega$
$V_{max-OFF}$	Maximum voltage that MOSFETS are OFF and before Turning ON			1.5	2.1	V
IQ	Quiescent Current	Detection Mode		25	50	$\mu\text{A}$
		Classification Mode		40	80	$\mu\text{A}$
		Operation Mode		50	90	$\mu\text{A}$
$V_{CL-ON}$	Classification ON threshold		11.5	12.5	13.5	V
$V_{CL-OFF}$	Classification OFF threshold		10.8	11.8	12.8	V
ISH	Shutdown/Leakage current when the MOSFETS are OFF				1	$\mu\text{A}$
VBF	Back Feed voltage	$V_{OUTP} = 57\text{V}$ , $V_{OUTN} = 0\text{V}$ , 100k $\Omega$ between IN1 and IN2 or IN3 and IN4			2.7	V

8. Guaranteed to meet performance specifications over the  $-40^{\circ}\text{C}$  to  $+125^{\circ}\text{C}$  operating temperature range by design, characterization, and correlation with statistical process controls.

## Typical Characteristics

$V_{IN} = 48V$ , Downstream PD = KTA1142, DC-DC  $V_o = 12V$ ,  $I_o = 6A$ ,  $T_A = 25^\circ C$ , unless otherwise specified.

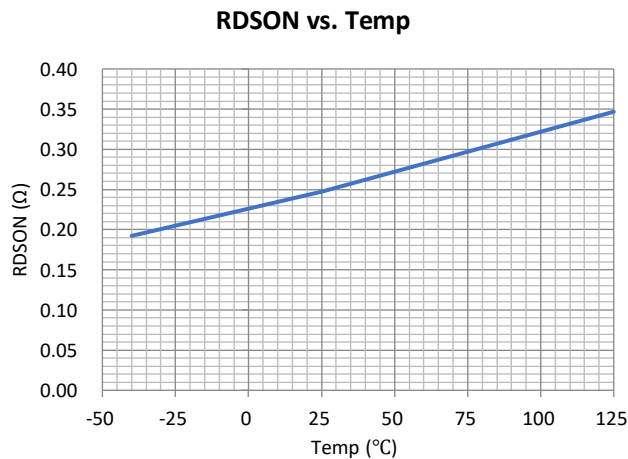
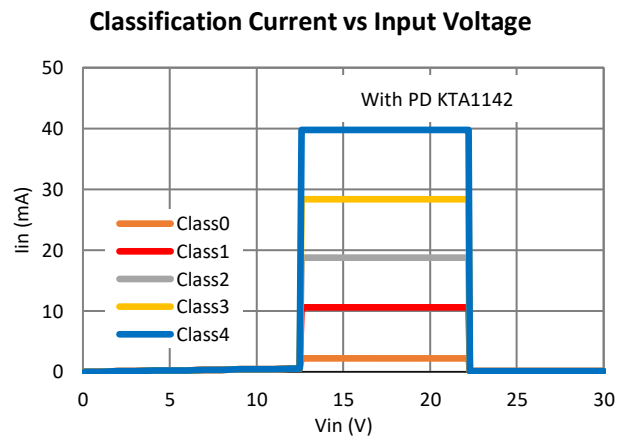
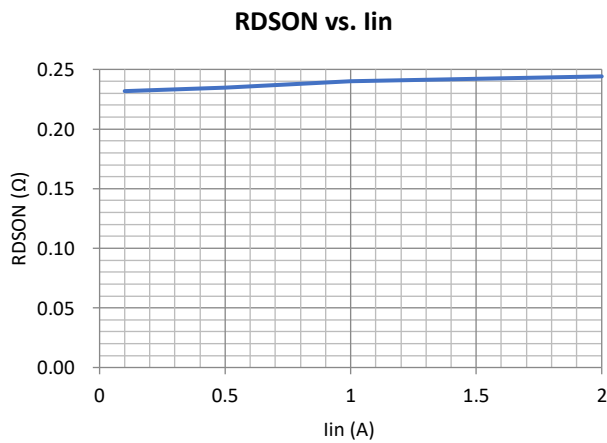
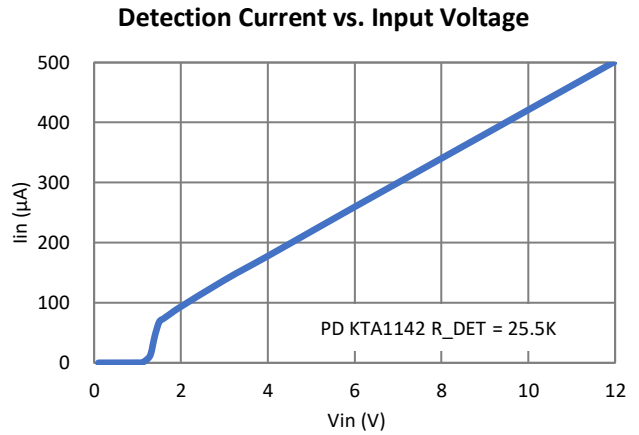
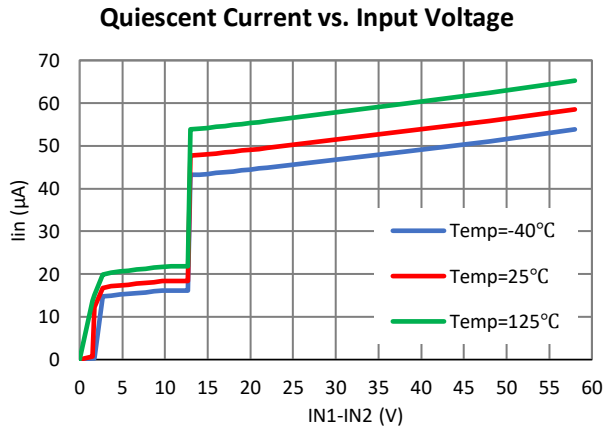

## Typical Characteristics (continued)

$V_{IN} = 48V$ , Downstream PD = KTA1142, DC-DC  $V_o = 12V$ ,  $I_o = 6A$ ,  $T_A = 25^\circ C$ , unless otherwise specified.

**Startup with PSE Input at Downstream 12V-0A Load**

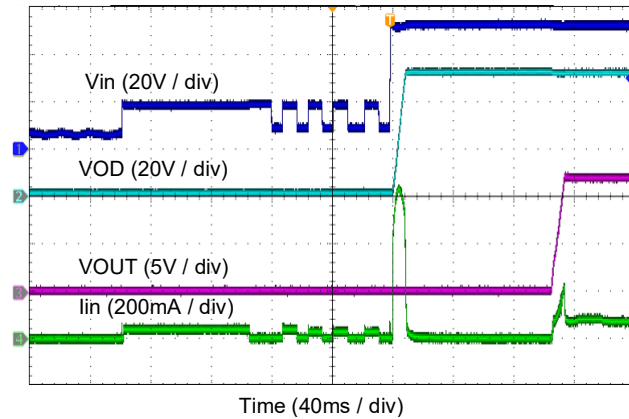

**Startup with PSE Input at Downstream 12V-6A Load**

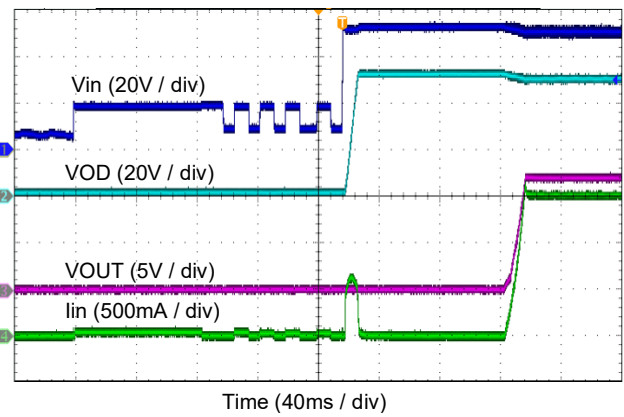

**Shutdown by PSE at Downstream 12V-0A Load**

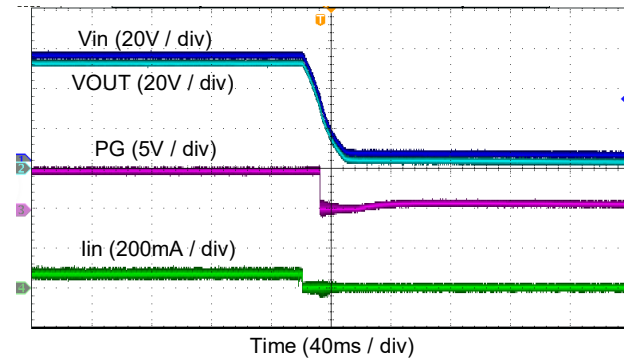

**Shutdown by PSE at Downstream 12V-6A Load**

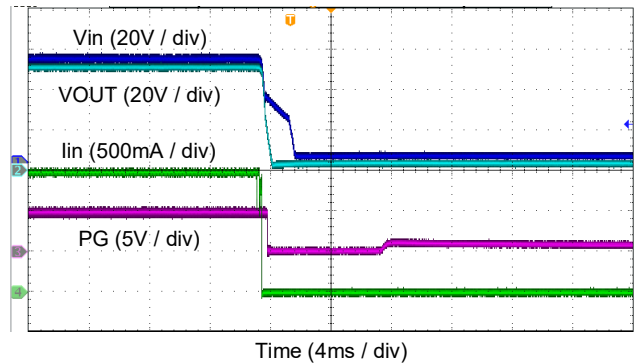

## Functional Block Diagram

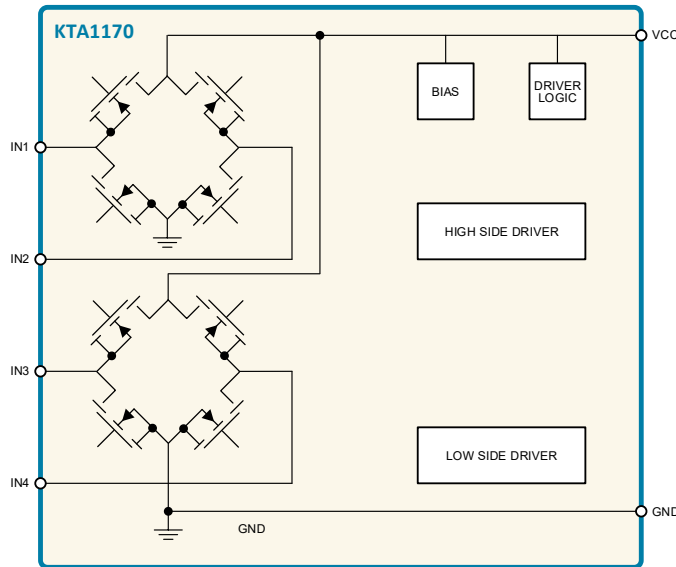

## Functional Description

### Overview of PoE

Power over Ethernet (PoE) offers an economical alternative for powering end network appliances, such as IP telephones, wireless access points, security and web cameras, and other powered devices (PDs). PoE standards IEEE® Std. 802.3af, 802.3at and 802.3bt are intended to unify the delivery method of usable power over Ethernet cables to remotely powered client devices. These standards define a method for detecting and querying PDs and then supplying a range of current levels based on the power class the device belongs to. By employing this method, designers can create systems that predict and minimize power usage, allowing the maximum number of devices to be supported on a powered Ethernet network.

The power source that provides current through the Ethernet cables to remote devices is referred to as the Power Sourcing Equipment (PSE). The powered device (PD) on the other end of the Ethernet cable negotiates for and receives the agreed-upon power. IEEE® Std. 802.3af limits PSE power delivery to <13W at the PD input (Type 1 PD). IEEE® 802.3at allows for >13W power levels and up to <25.5W (Type 2 PD). There are two higher power levels in IEEE® 802.3bt limit PSE power delivery to <51W (Type 3 PD) and <71.3 (Type 4 PD) at the PD input.

**Table 1. Classification Settings for PoE Power Device**

PD Requested Class	Standard	PD Power (Watt)	PSE Power (Watt)	PD Type	MAX Number of Events	2 or 4 Pair Power	Auto Class
0	802.3af	12.95	15.4	1	-	2 or 4 Pair	NO
1	802.3af	3.84	4	1	1	2 Pair Only	NO
2	802.3af	6.49	7	1	1	2 Pair Only	NO
3	802.3af	12.95	15.4	1	1	2 or 4 Pair	NO
4	802.3at	25.5	30	2	2	2 or 4 Pair	NO
5	802.3bt	38.25	45	3	4	4 Pair Mandatory	Optional
6	802.3bt	51	60	3	4	4 Pair Mandatory	Optional
7	802.3bt	62	75	4	5	4 Pair Mandatory	Optional
8	802.3bt	71.3	90	4	5	4 Pair Mandatory	Optional

The PSE uses the following sequence to detect a connected PD, determine how much power it requires and then initiate supply current to the device:

- **Reset** — Power is withdrawn from the PD if the applied voltage falls below a specified level.
- **Signature Detection** — The PSE detects and evaluates whether the PD is a valid PoE device.
- **Classification** — The PSE reads the power requirement of the PD. The Classification level identifies how much power the PD will require from the Ethernet line. This permits optimum use of the total power available from the PSE.
- **On** — Operational state, during which the PSE provides the allocated power level to the PD.

This sequence occurs as a progressively rising voltage level from the PSE. It is designed to prevent high voltages from being present on an Ethernet line that does not have a valid PD attached (for user and non-PoE device safety).

To design PoE systems according to IEEE® standards, the following constraints listed in Table 2 apply:

**Table 2. PoE Requirements**

Requirement	Value
Input voltage at Type 1 PD interface	37V-57V
Input voltage at Type 2 PD interface	42.5V-57V
Input voltage at Type 3 PD interface	42.5V-57V
Input voltage at Type 4 PD interface	41.1V-57V
Output voltage from Type 1 PSE	44-57V
Output voltage from Type 2 PSE	50-57V
Output voltage from Type 3 PSE	50-57V
Output voltage from Type 4 PSE	52-57V
Minimum operating current limit, Type 1 @ PSE min output voltage	350mA
Minimum operating current limit, Type 2 @ PSE min output voltage	600mA
Minimum operating current limit, Type 3 @ PSE min output voltage	600mA per pair
Minimum operating current limit, Type 4 @ PSE min output voltage	960mA per pair

In some applications, where power is supplied by a non-compliant PSE, the sequences listed above are not executed. It is strongly recommended to apply the guidelines shown in Application Note AN167 for designing with the KTA1170.

**KTA1170 Details Overview**

The KTA1170 is a single-chip, highly integrated solution for voltage rectification on Power over Ethernet (PoE) Powered Devices. Applications include Voice over IP (VoIP) Phones, Wireless LAN Access Point, Security Cameras, WiMAX Terminals, Point-of-Sales Terminals, RFID Readers, Thin Clients and Notebook computers.

On-chip integration active bridges rectification provides small size solution to provide safe, low-impedance paths, resulting in superior reliability and efficiency. The KTA1170 is a dual ideal diode bridge designed to rectify independent DC channels into a single output. The KTA1170 can sense the input channels from |IN1-IN2| or |IN3-IN4| separately and connects them to the output with the correct polarity. KTA1170 can also sense the input channels from |IN1-IN2| and |IN3-IN4| together and connects them to the output with the correct polarity. A very common application is an IEEE 802.3 powered device which is required to accept voltage in either polarity at its RJ-45 input. Polarity correction devices allow the PD to work equally well with standard or cross-over cables and endspan or midspan PSEs. They also prevent the PD from back feeding current into the Ethernet cable. PD polarity correction is commonly done with a traditional diode bridge, but this results in an efficiency loss due to the forward drop generated across two conducting diodes. This voltage drop reduces the available supply voltage and dissipates significant power. The KTA1170 uses actively driven MOSFETs to reduce the forward voltage drop.

By maximizing available voltage and reducing power dissipation, the KTA1170 simplifies PD design and reduces power supply cost. It can also eliminate thermal design problems, costly heat sinks, and reduce PC board area.

## OPERATING MODES

### Shutdown Mode

When input voltage to KTA1170 is smaller than 1.5V, KTA1170 is in shutdown mode. All the high side and low side MOSFETs of the bridges are turned off in the shutdown mode.

### Detection Mode

In detection mode, the PSE detects and evaluates whether the PD is a valid PoE device.

When input voltage to KTA1170 is higher than 1.5V and lower than 12.5V, the KTA1170 will only activate low side MOSFETs of the bridges. The bridge current is carried by the MOSFETs' body diodes of the high side MOSFETs.

### Classification Mode

The PSE reads the power requirement of the PD during classification stage. The Classification level identifies how much power the PD will require from the Ethernet line. This permits optimum use of the total power available from the PSE. When input voltage to KTA1170 is higher than 12.5V, the KTA1170 will activate all the high side and low side MOSFETs of the bridge in the classification stage.

### Operation Mode (Ideal Diode Bridge Mode)

Operation mode state, during which the PSE provides the allocated power level to the PD. In operation mode, the input voltage at PD interface is over 37V, the KTA1170 can save power by activating all the high side and low side MOSFETs.

## Thermal De-Rating and Board Layout Considerations

The KTA1170 is capable of operating to an industrial temperature range of 85°C in ambient air and up to 125°C junction temperature, without forced cooling. A thermal pad on the underside of the package dissipates the heat generated by the PD die.

In higher power applications in PoE.bt level, designers must consider thermal dissipation as an integral part of their system architecture and plan to remove heat via this pad.

If the PCB landing pattern is properly designed, the WDFN package should exhibit a good thermal resistance. For adequate heat dissipation, the board layout must include a ground pad which provides both the ground connection and dissipates the heat energy produced in the chip. Adequate thermal vias are used to draw heat away from the package and to transfer it to the backside of the system PCB. Adequate area of copper and multiple layers of copper are used for good heat dissipation.

Applications Circuits

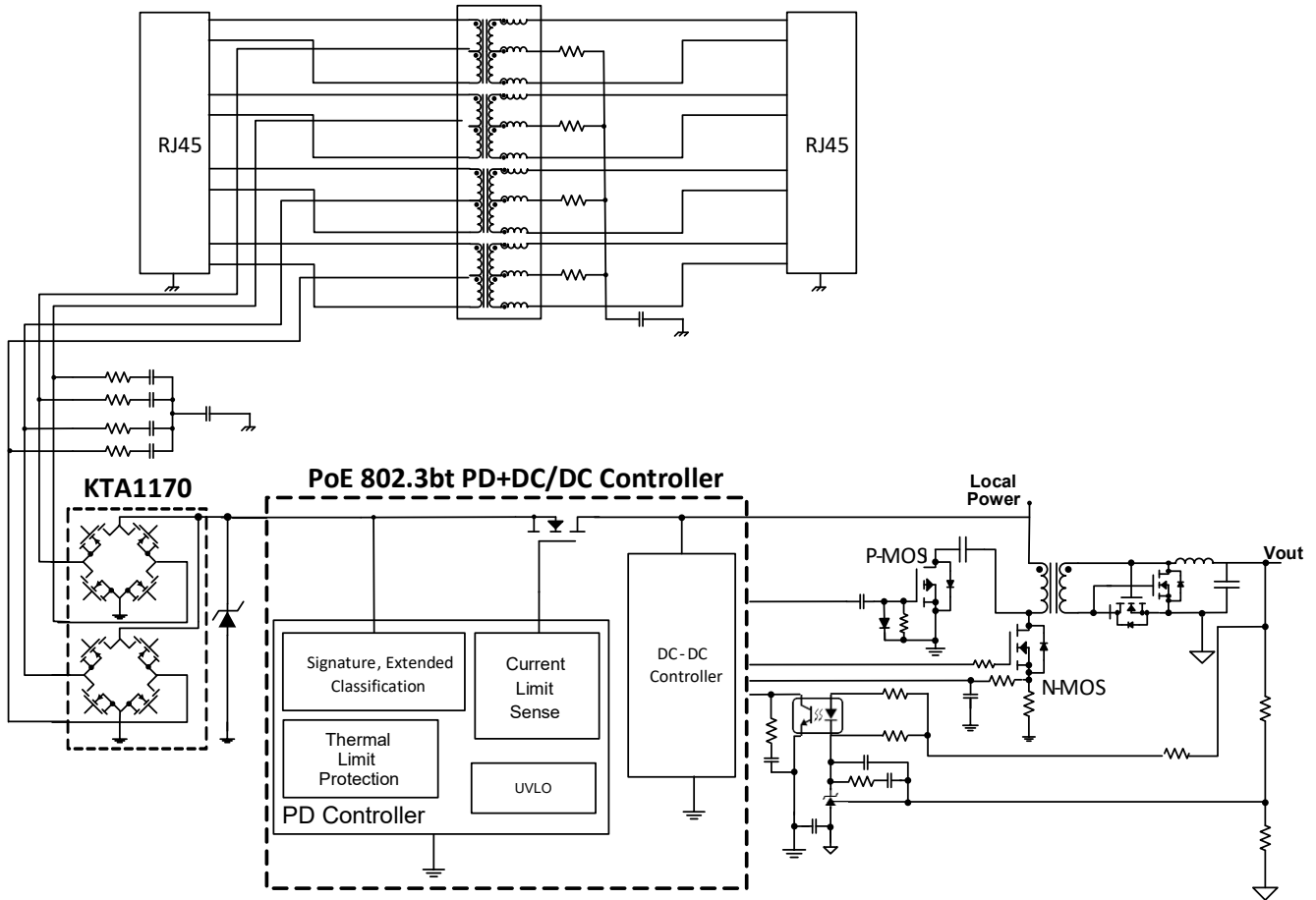
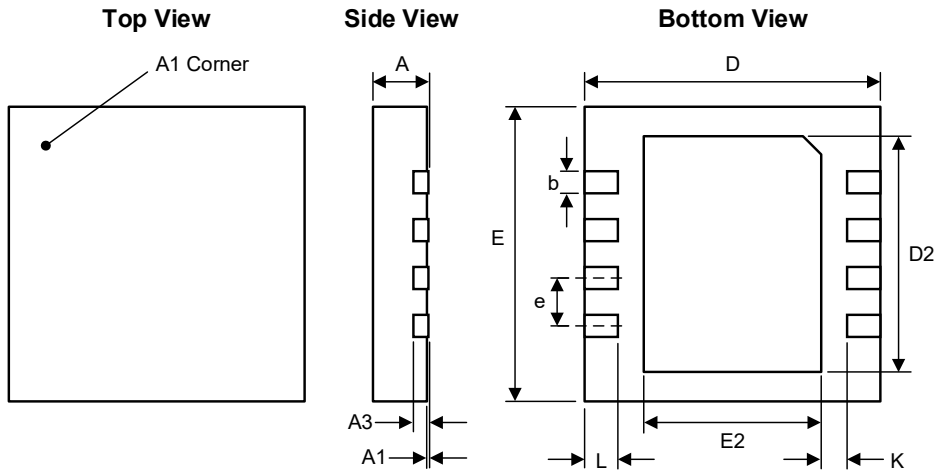

Figure 1. KTA1170+KTA1142 High-Efficiency Active Clamp Forward Solution for Higher Current Applications

Note: This is a simplified conceptual schematic. Please refer to the reference design documentation for detailed design and component information.

## Packaging Information

WDFN44-8 (4.00mm x 4.00mm x 0.75mm)



Dimension	mm		
	Min.	Typ.	Max.
A	0.70	0.75	0.80
A1	0.00	0.02	0.05
A3	0.203 REF		
b	0.25	0.30	0.35
D	3.90	4.00	4.10
D2	3.15	3.20	3.25
E	3.90	4.00	4.10
E2	2.35	2.40	2.45
e	0.65 BSC		
K	0.20	-	-
L	0.40	0.45	0.50

### Recommended Footprint

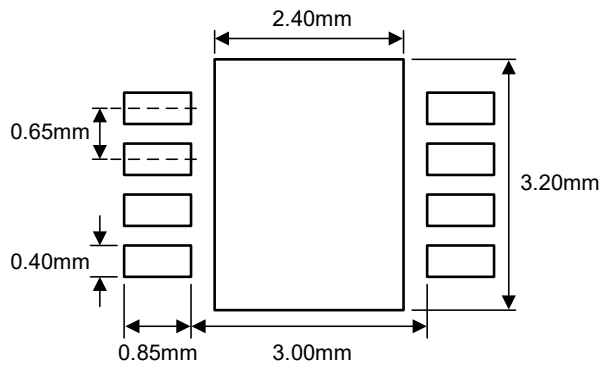

## Packing Material Information

### Reel Dimensions

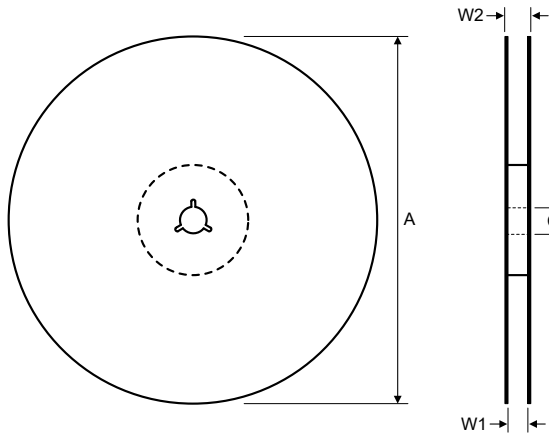

Dimension	mm		
	Min.	Typ.	Max.
A	179	180	180
C	12.8	13.0	13.2
W1	13	13	14
W2	14.4	15.4	16.4

DWG-0299-01

### Carrier Tape Dimensions

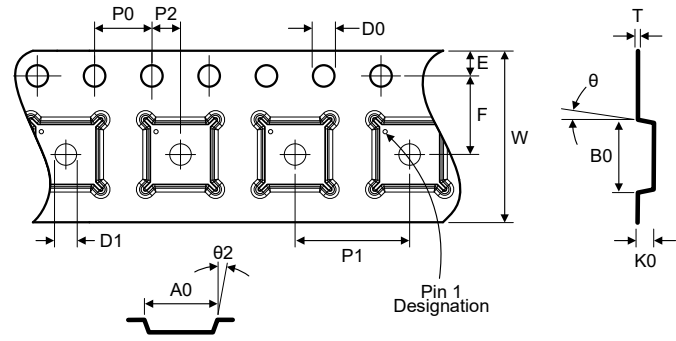

Dimension	mm		
	Min.	Typ.	Max.
A0	4.20	4.25	4.30
B0	4.20	4.25	4.30
K0	1.00	1.10	1.20
P0	3.80	4.00	4.20
P1	—	8.00	—
P2	1.95	2.00	2.05
D0	1.50	1.50	1.60
D1	1.50	—	—
E	1.65	1.75	1.85
F	5.45	5.50	5.55
10P0	38.0	40.0	42.0
W	11.90	12.00	12.30
T	0.25	0.30	0.35
$\theta$	0°		5°
$\theta 2$	0°		5°

DWG-0254-01

### Cover Tape Dimensions

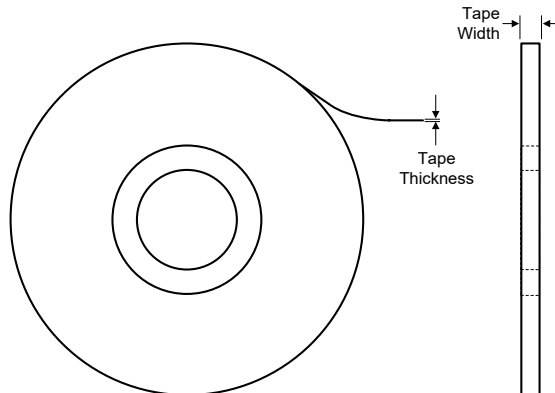

Dimensions	Dimension	mm		
		Min.	Typ.	Max.
9.3mm	Tape Thickness	0.047	0.052	0.057
	Tape Width	9.2	9.3	9.4

DWG-0298-01

Kinetic Technologies cannot assume responsibility for use of any circuitry other than circuitry entirely embodied in a Kinetic Technologies product. No intellectual property or circuit patent licenses are implied. Kinetic Technologies reserves the right to change the circuitry and specifications without notice at any time.