

**IEEE 802.3af/at/bt PoE PD and Flyback Controller**

**Brief Description**

The KTA1140 Evaluation (EVAL) Kit is used to demonstrate and evaluate the KTA1140’s functionality, performance, and PCB layout. The kit includes a fully assembled and tested PCB with the KTA1140 IC installed. The KTA1140 device is an IEEE 802.3af/at/bt compliant power supply controller optimized for isolated and non-isolated converter topologies. Along with the KTA1140, this evaluation board also utilizes Kinetic’s KTB1095 and KTA1170. The KTB1095 is a 12V, 50W flyback topology voltage regulator that integrates a gate driver for a fully synchronous output rectifier along with a built-in digital isolator that can provide up to 3000 Volts RMS isolation. The KTA1170 is a single chip dual MOSFET bridge rectifier that can improve power conversion efficiency up to 2% at higher loads. Together, they provide a highly integrated and compact solution that can enable smaller footprint designs. The KTA1140 evaluation board has power and signal I/O connections with an array of test points for signal observation.

Please note that there is an alternative KTA1140 kit created for the evaluation of the KTA1140 together with the KTB2140 Active Clamp Current-Mode PWM Controller. Contact a Kinetic Technologies sales representative for further details.

**Ordering Information**

Part Number	Description	IC Package
KTA1140EUAQ-WA-MCEV01	KTA1140 EVAL Kit – including KTB1095 and KTA1170	WQFN55-20



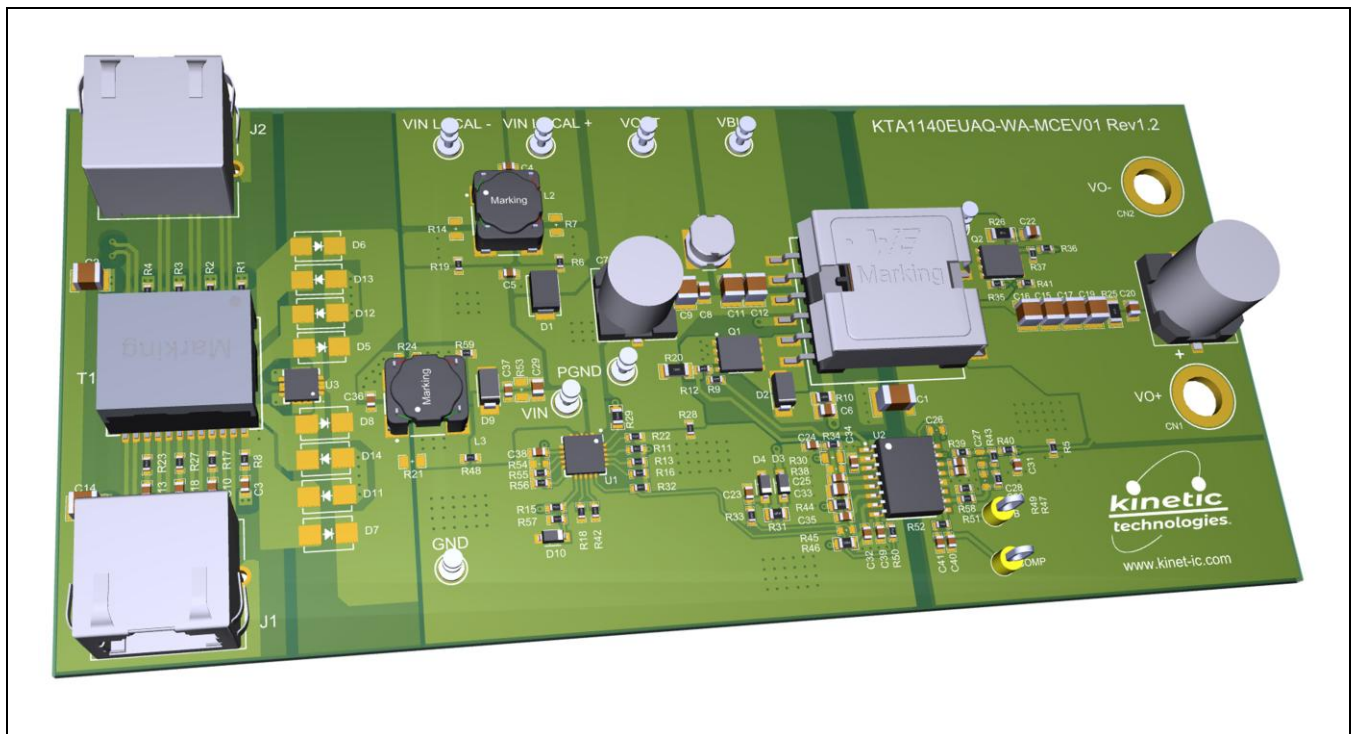

**3D CAD Image**



## EVAL Kit Physical Contents

Item #	Description	Quantity
1	KTA1140 (+KTB1095) Evaluation board fully assembled PCB	1
2	Anti-static bag	1
3	KTA1140 (+KTB1095) Quick Start Guide, printed 1 page (A4 or US Letter)	1
4	EVAL Kit box	1

## QR Links for Documents

<b>KTA1140 IC Datasheet</b>  <a href="https://www.kinet-ic.com/kta1140/">https://www.kinet-ic.com/kta1140/</a>	<b>KTA1140 (+KTB1095) EVAL Kit Landing Page</b>  <a href="https://www.kinet-ic.com/kta1140euag-wa-mcev01/">https://www.kinet-ic.com/kta1140euag-wa-mcev01/</a>
<b>KTB1095 IC Datasheet</b>  <a href="https://www.kinet-ic.com/ktb1095/">https://www.kinet-ic.com/ktb1095/</a>	<b>KTA1170 IC Datasheet</b>  <a href="https://www.kinet-ic.com/kta1170/">https://www.kinet-ic.com/kta1170/</a>

## User-Supplied Equipment

### Required Equipment

1. An IEEE 802.3 standards compliant Power Sourcing Equipment (PSE), PoE power injector or PoE powered network switch that can source 48V at 60W or greater.
  - a. Alternatively, a bench Power Supply may be substituted for a PoE power injector, but this will bypass the KTA1140 functionality. Such a supply should provide 37V-57V up to 2A as needed for intended application.
  - b. When sourcing power from non-compliant PSE environments, which have no PD detection or handshaking, ensure that the fastest rise time is 15 $\mu$ s from 10%-90% of 57V (maximum from POWER\_ON to POWER\_UP as per the IEEE802.3 standards).
2. CAT-5, CAT-5e or CAT-6 RJ45 M/M ethernet cable, 1m length or shorter.
3. Digital Multimeters, two required – used to measure input/output voltages and currents.
4. Load – any of the following may be used:
  - a. Electronic load capable of sinking 12V at 4.17A (50W)
  - b. Power Resistor - 2.87 $\Omega$  / 50W or greater value is required
  - c. Actual system load that does not exceed 50W at 12V
5. Test leads:
  - a. One pair of banana-to-clip test leads to connect a voltmeter to the eval board VIN
  - b. Two pairs of banana-jack test leads to connect VO+/VO- to an electronic load and volt meter

### Optional Equipment

1. Oscilloscope with 10x probes to monitor switching regulator waveforms

## Recommended Operating Conditions

Parameter	Description	Value	Units
Input Voltage	PoE PSE/Injector to the J1 RJ45 connector	48	V
	Bench Supply applied to the VIN Local +/- Pins	37-57	V
Output Voltage	VO+ to VO-	12	V
Output Current	Max Load = 50W (12V @ 4.17A)	4.17	A

## Quick Start Procedures

The output voltage of this board is set to 12V by the Kinetic Technologies KTB1095 flyback controller. There are two methods to power KTA1140 (+KTB1095) evaluation board:

Method 1: Connect to an IEEE802.3 standards compliant PSE

1. Connect a voltage meter between the VIN and GND test points to monitor the input supply voltage.
2. Connect a voltage meter to the VO+ and VO- output jacks to monitor the regulated output voltage.
3. Connect the load to the output VO+ and VO- output jacks.
4. Connect the RJ45 ethernet cable from the PSE into the evaluation board ethernet Jack J1. The board will automatically startup.

Method 2: Connect to Local Power Supply

1. Connect one pair of power cables to the Test pins (VIN LOCAL + and VIN LOCAL -) of EVAL Kit.
2. Before connecting the EVAL Kit to the bench power supply, turn on the supply and adjust the voltage as close to 0V as possible. Then disable the power supply output or turn the supply off. While disabled or off, connect the VIN LOCAL + / VIN LOCAL - power cables' ends to the bench supply.
3. Connect a voltage meter to the VO+ and VO- output jacks.
4. Connect the load to the output VO+ and VO- output jacks.
5. Turn on the VIN bench supply and very slowly ramp its voltage to an appropriate voltage, such as 48V (9.5V ~ 57V). While ramping VIN slowly, use the bench supply's output current indication (or a digital multimeter) to monitor the VIN current. If the current becomes high, reduce the VIN voltage quickly to prevent damage. Then inspect the setup for any wiring errors.
6. Verify 12 Volts on the VO+ / VO- output jacks.
7. If power is sourced from a non-compliant PSE and supplied through an RJ45 ethernet cable, see Required Equipment section above, item 1b.

## General Configuration

### Connector Functionality

Connector	Description
J1	Ethernet power input connector (RJ45 connector)
J2	Ethernet data port connector (RJ45 connector)
VO-, VO+	VOOUT (output) to system DC power
VIN LOCAL -	Adapter ground, PGND
VIN LOCAL +	External Power Supply/Adaptor (9.5V ~ 57V), VADP

### Typical Test Setup

The figure below shows a typical setup for KTA1140 (+KTB1095) EVB. Input voltage can be applied as described in the Connector Functionality table above.

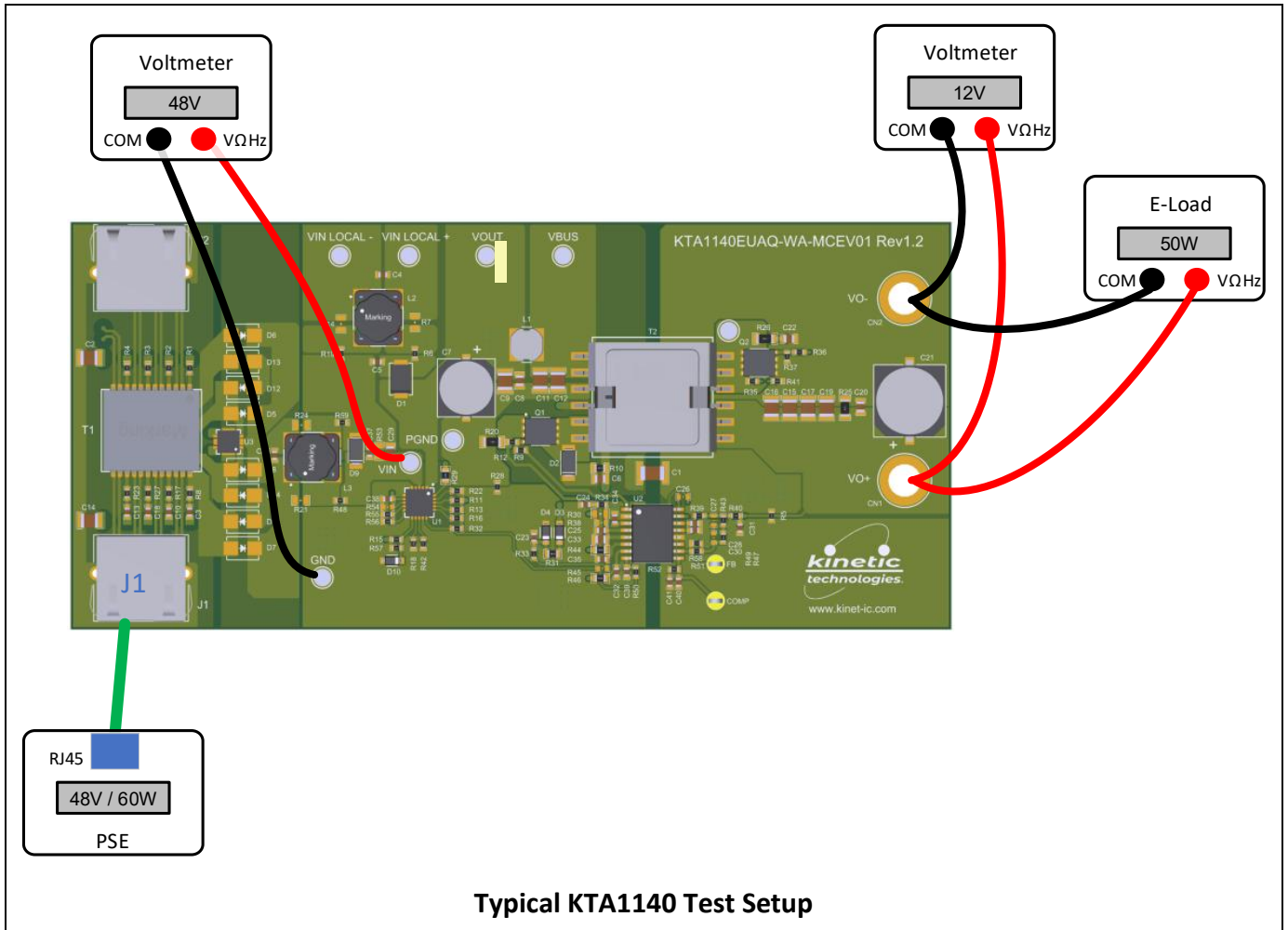



### Bill of Materials

Quantity	Designator	Description	Value	Package	Manufacturer	Manufacturer Part Number
1	C1	CAP CER 4700pF 2KV X7R 1812	4.7nF	1812	Yageo	CC1812KKX7RDBB472
2	C2, C14	CAP 1nF 2KV X7R 1210	1nF	1210	Johanson Dielectrics Inc.	202S41W102KV4E
4	C3, C10, C13, C18	CAP CER 0.01μF 100V X7R 0603	0.01μF	0603	Samsung	CL10B103KC8NNNC
4	C4, C5, C36, C37	CAP CER 100pF 100V X7R 0603	100pF	0603	Yageo	CC0603KRX7R0BB101
1	C6	CAP CER 0.022μF 200V X7R 0805	22nF	0805	Yageo	CC0805KKX7RABB223
1	C7	CAP ALUM 47μF 20% 100V SMD	47μF		Nichicon	UUR2A470MNL1GS
3	C8, C20, C33	CAP CER 0.1μF 100V X7R 0805	0.1μF	0805	Yageo	CC0805KKX7R0BB104
3	C9, C11, C12	CAP CER 4.7μF 100V X7S 1210	4.7μF	1210	Taiyo Yuden	HMK325C7475KN-TE
4	C15, C16, C17, C19	CAP CER 47μF 16V X5R 1210	47μF	1210	Samsung	CL32A476KOJNNNE
1	C21	CAP ALUM 330μF 20% 50V SMD	330μF		Vishay	MAL215099112E3
1	C22	CAP CER 220pF 200V X7R 0805	220pF	0805	Yageo	CC0805KRX7RABB221
7	C23, C28, C30, C31, C34, C35, C38	CAP CER 1.0μF 50V X7R 0603	1μF	0603	YAGEO	CC0603KRX7R9BB105
4	C24, C25, C39, C40	CAP CER 0.1μF 50V X7R 0603	0.1μF	0603	Samsung	CL10B104KB8NNNC
2	C26, C27	CAP 0603	DNP	0603		
1	C29	CAP CER 0.068μF 100V X7R 0805	68nF	0805	Yageo	CC0805KKX7R0BB683
1	C32	CAP CER 1200pF 100V COG 0603	1.2nF	0603	TDK	CGA3E2COG2A122JT0Y0N
1	C41	CAP CER 2200pF 50V X7R 0603	2.2nF	0603	Samsung	CL10B222KB8NNNC
2	CN1, CN2	Banana Jack, 4mm, Socket, Solder Hole - Uninsulated		TH	Cal Test Electronics	CT2220
9	D1, D5, D6, D7, D8, D11, D12, D13, D14	DIODE SCHOTTKY 100V 2A SMB		SMB	Diodes Inc	B2100-13-F
1	D2	DIODE GEN PURP 200V 1A DO214AC		DO-214AC-214 ON	Vishay Semiconductor	ES1D-E3/61T
1	D3	DIODE GEN PURP 100V 200MA SOD123		SOD123	onsemi	MMSD4148T1G
1	D4	DIODE ZENER 27V 410MW SOD123		SOD123	Vishay General Semiconductor - Diodes Division	BZT52C27-E3-08
1	D9	TVS DIODE 58VWM 93.6VC DO214AC		DO-214AC, SMA	Littelfuse Inc.	SMAJ58A
1	D10	DIODE ZENER 5.6V 500MW SOD123		SOD123	Diodes Inc	BZT52C5V6-7-F
2	J1, J2	CONN MOD JACK 8P8C R/A SHIELDED		None	TE Connectivity	1-406541-1
1	L1	FIXED IND 6.8μH 2.8A 47.3MΩ SM	6.8μH	SMD	Bourns Electronics	SRN6045-6R8Y
2	L2, L3	WE-SL5 SMT Common Mode Line Filter, 250μH, 2A, 0.035Ω			Würth Elektronik	744272251

Quantity	Designator	Description	Value	Package	Manufacturer	Manufacturer Part Number
1	Q1	Power Field-Effect Transistor, 3.2A I(D), 200V, 0.09Ω, 1-Element, N-Channel, Silicon, Metal-oxide Semiconductor FET		PowerTDFN-8	Vishay Siliconix	SI7450DP-T1-E3
1	Q2	MOSFET N-CH 80V 11A/55A TDSO			Infineon Technologies	BSC123N08NS3GATMA1
8	R1, R2, R3, R4, R8, R17, R23, R27	RES 75Ω 1% 1/10W 0603	75	0603	Yageo	RC0603FR-0775RL
1	R5	Fixed Resistor, Metal Glaze/thick Film, 0.1W, 0Ω, Surface Mount, 0603	0	0603	Yageo	RC0603FR-070RL
13	R6, R9, R19, R22, R28, R33, R36, R39, R40, R48, R50, R51, R59	RES 0Ω JUMPER 1/10W 0603	0	0603	Yageo	RC0603FR-070RL
6	R7, R14, R21, R24, R30, R53	RES 0805	DNP	0805		
1	R10	RES 100KΩ 1% 1/4W 0805	100K	0805	Yageo	RC0805FR-7W100KL
6	R11, R12, R13, R16, R37, R58	RES 10KΩ 1% 1/10W 0603	10K	0603	Yageo	RC0603FR-0710KL
1	R15	RES SMD 510KΩ 1% 1/10W 0603	510K	0603	Yageo	RT0603FRE07510KL
1	R18	RES 237KΩ 1% 1/10W 0603	237K	0603	Yageo	RC0603FR-07237KL
1	R20	RES 0.005Ω 1% 1W 1206	5m	1206	Vishay Dale	WSP12065L000FEA
1	R25	RES 10KΩ 1% 1/4W 1206	10K	1206	Yageo	RC1206FR-1010KL
1	R26	RES 10Ω 1% 1/4W 1206	10	1206	Yageo	RC1206FR-0710RL
1	R29	RES 25.5KΩ 1% 1/8W 0805	25.5K	0805	Yageo	RC0805FR-0725K5L
1	R31	RES 0Ω JUMPER 1/8W 0805	0	0805	Yageo	RC0805FR-070RL
1	R32	RES 47.5KΩ 1% 1/10W 0603	47.5K	0603	Yageo	RC0603FR-0747K5L
1	R34	RES 200Ω 1% 1/10W 0603	200	0603	Yageo	RC0603FR-07200RL
2	R35, R41	RES 100Ω 1% 1/10W 0603	100	0603	Yageo	RC0603FR-07100RL
4	R38, R45, R49, R54	RES 0603	DNP	0603		
1	R42	RES 60.4KΩ 1% 1/10W 0603	60.4K	0603	Yageo	RC0603FR-0760K4L
1	R43	RES 301Ω 1% 1/10W 0603	301	0603	Yageo	RC0603FR-07301RL
1	R44	RES 10Ω 1% 1/8W 0805	10	0805	Yageo	RC0805FR-0710RL
1	R46	RES 150KΩ 1% 1/8W 0805	150K	0805	Yageo	RC0805FR-07150KL
1	R47	RES 88.7KΩ 1% 1/10W 0603	88.7K	0603	Yageo	RC0603FR-0788K7L
1	R52	RES 24KΩ 1% 1/10W 0603	24K	0603	Yageo	RC0603FR-0724KL
1	R55	RES 63.4KΩ 1% 1/10W 0603	63.4K	0603	Yageo	RC0603FR-0763K4L
1	R56	RES 90.9KΩ 1% 1/10W 0603	90.9K	0603	Yageo	RC0603FR-0790K9L
1	R57	RES 30KΩ 1% 1/10W 0603	30K	0603	Yageo	RC0603FR-0730KL
1	T1	WE-LAN LAN Transformer, SMT, 1000 Base-T, 1 port			Würth Elektronik	7490220122
1	T2	Power Over Ethernet (PoE) For DC/DC Converters SMPS Transformer 1500Vrms Isolation 250kHz Surface Mount			Würth Elektronik	750319036



# EVAL Kit Manual

## KTA1140 (+KTB1095)

Quantity	Designator	Description	Value	Package	Manufacturer	Manufacturer Part Number
8	TP1, TP2, TP3, TP4, TP5, TP6, TP7, TP8	TERM TURRET SINGLE L=5.56MM TIN		1POS	Keystone	1502-2
2	TP9, TP10	PC TEST POINT MULTIPURPOSE YELLOW		Through Hole	Keystone	5014
1	U1	IEEE 802.3bt-Compliant, Powered Device Interface Controller		TQFN55-20	Kinetic Technologies	KTA1140EUAQ-TB
1	U2	Isolated Synchronous Flyback Controller with Integrated Feedback and Digital Isolator		SOIC-16	Kinetic Technologies	KTB1095EYAA-TE
1	U3	Integrated Dual MOSFET Bridge Rectifier		DFN44-8	Kinetic Technologies	KTA1170GVAE-TB

Printed Circuit Board (PCB)

Top Side Layout/Routing

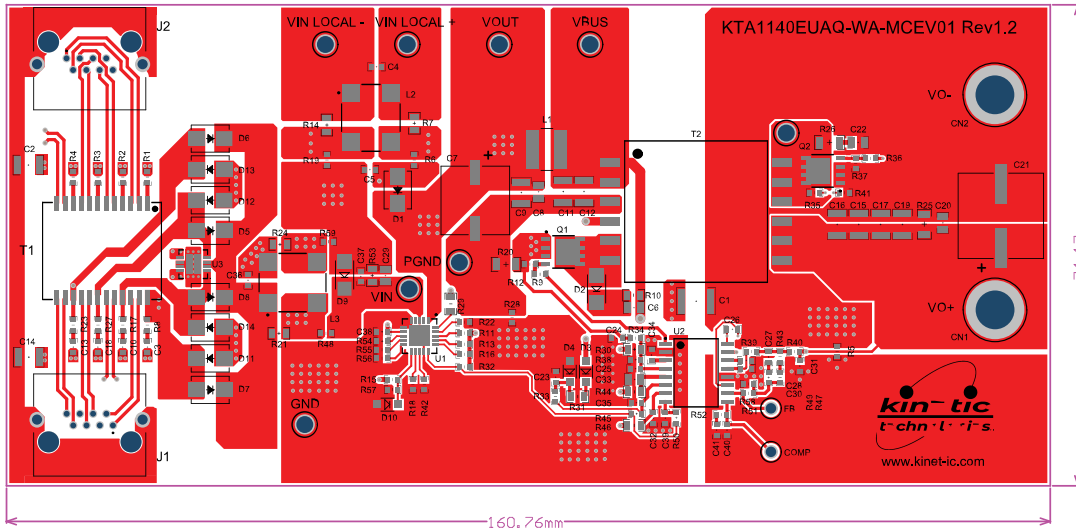

Layer Two Routing

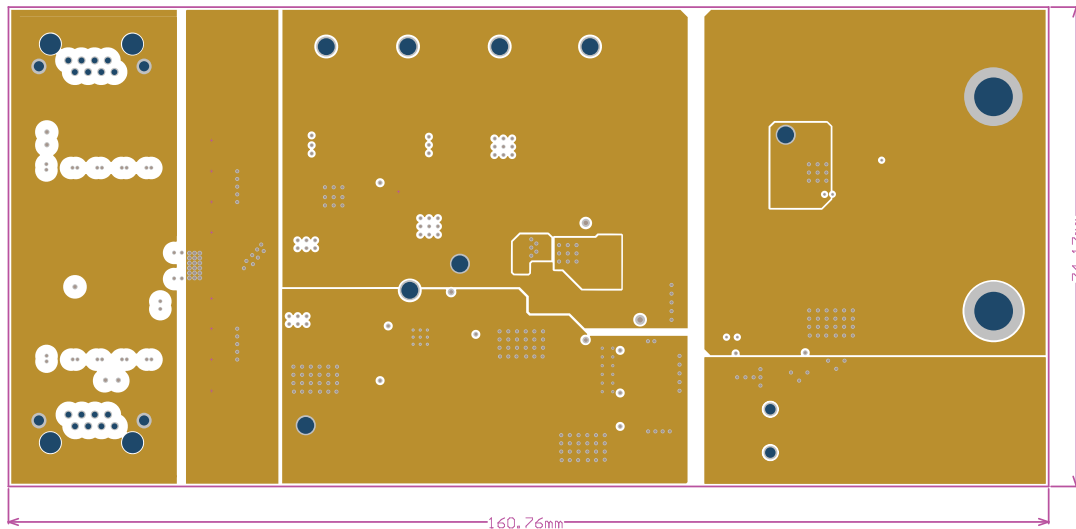

**Layer Three Routing**

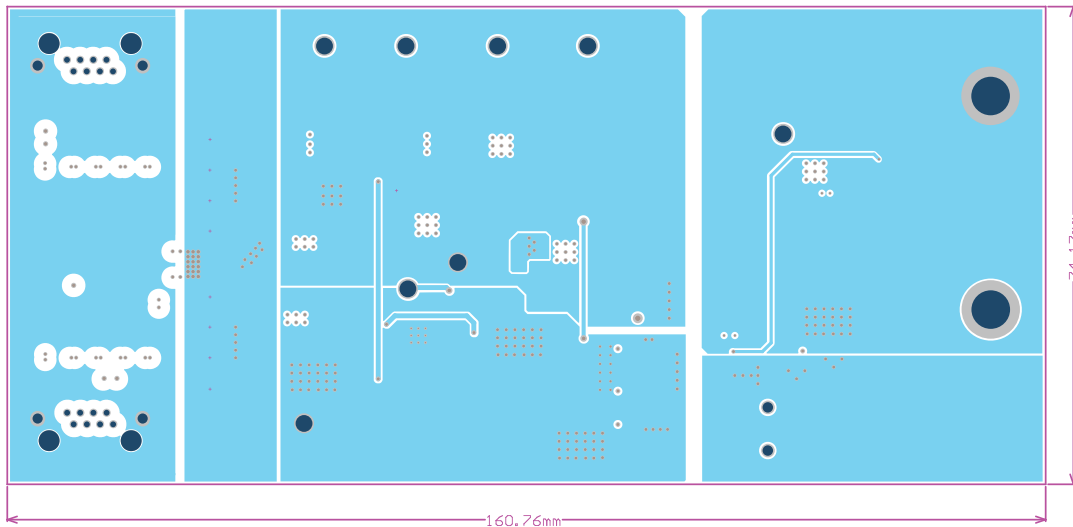

**Bottom Layer Routing**

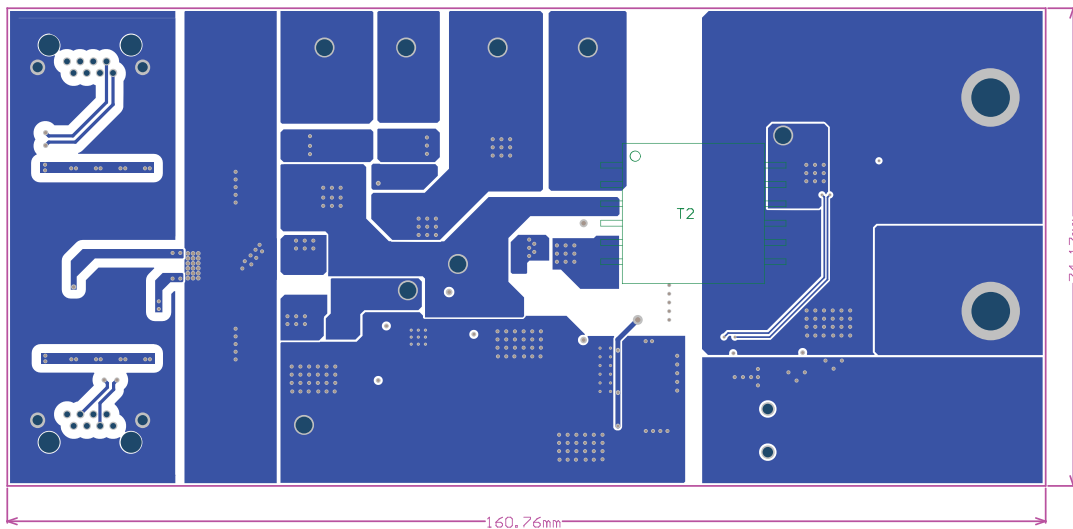

## Test Setup

1. The “Typical Test Setup Diagram” shows a typical setup for the KTA1140 (+KTB1095) EVAL board. Input voltage can be applied as described in the “Recommended Operating Conditions” Table
2. When an IEEE802.3 standards compliant PSE, PoE injector or PoE capable switch is used to source VIN power, the KTA1140 will automatically start up and 12V may be observed on the output VO+/VO- pins. If power is sourced from a non-compliant PSE and supplied through an RJ45 ethernet cable, see Required Equipment section above, item 1b.
3. If an external bench power supply is used to source power to the VIN LOCAL+ and VIN LOCAL- input pins, the KTA1140 functionality will be bypassed. However, when power is applied to this input, the KTB1095 flyback regulator will supply 12V to the output and loads may be applied.
4. Digital multimeters may be used to monitor the input voltage level (VIN to GND) and output voltage levels at VO+/VO-
5. A load may be applied to the output at VO+/VO-. The load should not exceed 50W (4.17A at 12V)

## Important Notices

### Legal notice

Copyright © Kinetic Technologies. Other names, brands and trademarks are the property of others.

Kinetic Technologies assumes no responsibility or liability for information contained in this document. Kinetic Technologies reserves the right to make corrections, modifications, enhancements, improvements, and other changes to its products and services at any time and to discontinue any product or services without notice. The information contained herein is believed to be accurate and reliable at the time of printing.

### Reference design policy

This document is provided as a design reference and Kinetic Technologies assumes no responsibility or liability for the information contained in this document. Kinetic Technologies reserves the right to make corrections, modifications, enhancements, improvements, and other changes to this reference design documentation without notice.

Reference designs are created using Kinetic Technologies' published specifications as well as the published specifications of other device manufacturers. This information may not be current at the time the reference design is built. Kinetic Technologies and/or its licensors do not warrant the accuracy or completeness of the specifications, or any information contained therein.

Kinetic Technologies does not warrant that the designs are production worthy. Customer should completely validate and test the design implementation to confirm the system functionality for the end use application.

Kinetic Technologies provides its customers with limited product warranties, according to the standard Kinetic Technologies terms and conditions.

For the most current product information visit us at [www.kinet-ic.com](http://www.kinet-ic.com)

### Life support policy

LIFE SUPPORT: KINETIC TECHNOLOGIES' PRODUCTS ARE NOT DESIGNED, INTENDED, OR AUTHORIZED FOR USE AS COMPONENTS IN LIFE SUPPORT DEVICES OR SYSTEMS. NO WARRANTY, EXPRESS OR IMPLIED, IS MADE FOR THIS USE. AUTHORIZATION FOR SUCH USE SHALL NOT BE GIVEN BY KINETIC TECHNOLOGIES, AND THE PRODUCTS SHALL NOT BE USED IN SUCH DEVICES OR SYSTEMS, EXCEPT UPON THE WRITTEN APPROVAL OF THE PRESIDENT OF KINETIC TECHNOLOGIES FOLLOWING A DETERMINATION BY KINETIC TECHNOLOGIES THAT SUCH USE IS FEASIBLE. SUCH APPROVAL MAY BE WITHHELD FOR ANY OR NO REASON.

“Life support devices or systems” are devices or systems which (1) are intended for surgical implant into the human body, (2) support or sustain human life, or (3) monitor critical bodily functions including, but not limited to, cardiac, respirator, and neurological functions, and whose failure to perform can be reasonably expected to result in a significant bodily injury to the user. A “critical component” is any component of a life support device or system whose failure to perform can be reasonably expected to cause the failure of the life support device or system, or to affect its safety or effectiveness.

### SUBSTANCE COMPLIANCE

Kinetic Technologies IC products are compliant with RoHS, formally known as Directive 2002/95/EC of the European Parliament and of the Council of 27 January 2003 on the restriction of the use of certain hazardous substances in electrical and electronic equipment. However, this evaluation kit does not fall within the scope of the EU directives regarding electromagnetic compatibility, restricted substances (RoHS), recycling (WEEE), FCC, CE or UL, and may not meet the requirements of these or related directives. To the best of our knowledge the information is true and correct as of the date of the original publication of the information. Kinetic Technologies bears no responsibility to update such statement.