

Surge Protected Load Switch with OVP and OCP

Features

- Surge and ESD protected Input
 - Surge Protection
 - IEC 61000-4-5: $\pm 110V$
 - ESD Protection
 - IEC 61000-4-2 (Level 4)
 - Contact: $\pm 8kV$
 - Air Gap: $\pm 15kV$
 - Human Body Model $\pm 2kV$
- Safety approvals
 - UL 2367, file no. E515099-20210819
 - IEC 62368-1, file no. DK-118085-UL
- Wide Input voltage range
 - 2.7V to 28V
- Low Quiescent Current 140 μA typ.
- Integrated 9m Ω (typ) N-Ch MOSFET
- Fast turn-off response time 100ns
- Programmable OCP trip point: 1.0A ~ 6.0A
 - 8A maximum limit
- Flexible overvoltage trip-point options
 - Fixed 5.95V or Adj. 4V to 22V
- Auto-enabled switch with typ. 0.7ms debounce time
- Additional Under-voltage (UVLO), Short-circuit and thermal shutdown protection
- Open-drain power good output
- Pb-free WLCSP-20 package
- RoHS and Green Compliant
- -40°C to +85°C Temperature Range

Applications

- Smartphones
- Tablet, Computers
- Mobile Internet Devices, Peripherals

Brief Description

The KTS1693 overvoltage protection device features an ultra-low 9m Ω (typical) on-resistance high current integrated MOSFET which actively protects low-voltage systems from voltage supply faults up to +28VDC. An internal clamp protects the device from surges up to $\pm 110V$.

An input voltage exceeding the overvoltage threshold will cause the internal MOSFET to turn off, preventing excessive voltage from damaging downstream devices.

When the OVLO pin input is set below the external OVLO select voltage, the KTS1693 automatically chooses the internal fixed OVLO threshold, preset to 5.95V (typical). The overvoltage protection threshold is adjustable with an optional resistor divider to a voltage between 4V and 22V.

The device includes an over-current protection (OCP) circuit which is programmable via an external resistor.

The open-drain output \overline{ACOK} indicates a stable supply between the minimum supply voltage and OVLO threshold. It also deasserts after 8ms if the switch is in OCP mode when OC_MODE = Low. In case of a fault condition and the device temperature exceeds the maximum junction temperature, the device switches off. The KTS1693-1 has a VDET pin instead of \overline{ACOK} pin for VBUS detection function. VDET pin provides a “clamped” output voltage whenever a voltage appears on VIN, even if the power switch is off due to an overvoltage condition.

The KTS1693 is available in a RoHS and Green compliant 20-Bump 2.160 x 1.935mm WLCSP.

Typical Application

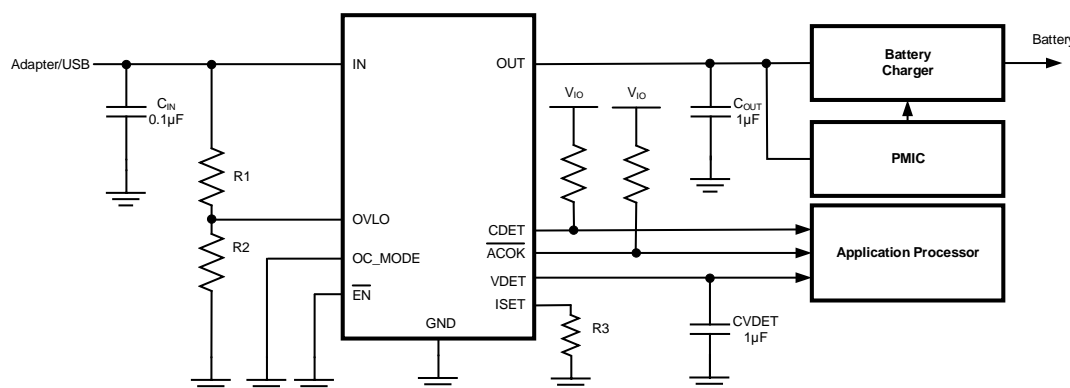

* NOTE: \overline{ACOK} pin for KTS1693, VDET pin for KTS1693-1

Pin Descriptions

Pin #	Name	Function
A1	CDET	Open-Drain Output for IN to OUT current detection. CDET is pulled low when $I_{IN} < 50\text{mA}$ (typ). Connect a pull-up resistor between the logic pin and the system rail.
A2,A3,A4, B2,B3,C2	OUT	Output of internal main high-current power switch.
B1	$\overline{\text{EN}}$	Device Enable(Active Low). This pin cannot be left floating.
B4	OC_MODE	OCP behavior select pin with internal pull-up $5\text{M}\Omega$. HIGH: Auto restart mode during over-current condition. LOW: Over-current protection mode during over-current condition.
C4,D4	GND	Ground. Connect GND pins together on the PCB for correct operation.
C1(KTS1693)	$\overline{\text{ACOK}}$	Open-Drain Power Good Output. $\overline{\text{ACOK}}$ is pulled Low when the input supply voltage is above the UVLO threshold and stable. The $\overline{\text{ACOK}}$ pin de-asserts if an UVLO, OVLO, OCP or OTP condition is present. Connect a pull-up resistor between the logic pin and the system rail.
C1(KTS1693-1)	VDET	Output from IN pin, with internal protection clamp. VDET can source 3mA current. A small $1\mu\text{F}$ bypass capacitor is required on VDET pin.
C3,D2,D3, E2,E3,E4	IN	Voltage Input. Bypass IN with $0.1\mu\text{F}$ capacitor as close as possible to the device.
D1	OVLO	External OVLO adjustment. Connect OVLO to GND when using the internal threshold. Connect a resistor-divider to OVLO to set a different OVLO threshold.
E1	ISET	Input over-current protection setting. Connect a resistor to GND to set the over-current protection threshold. This pin cannot be left floating.

WLCSP-20

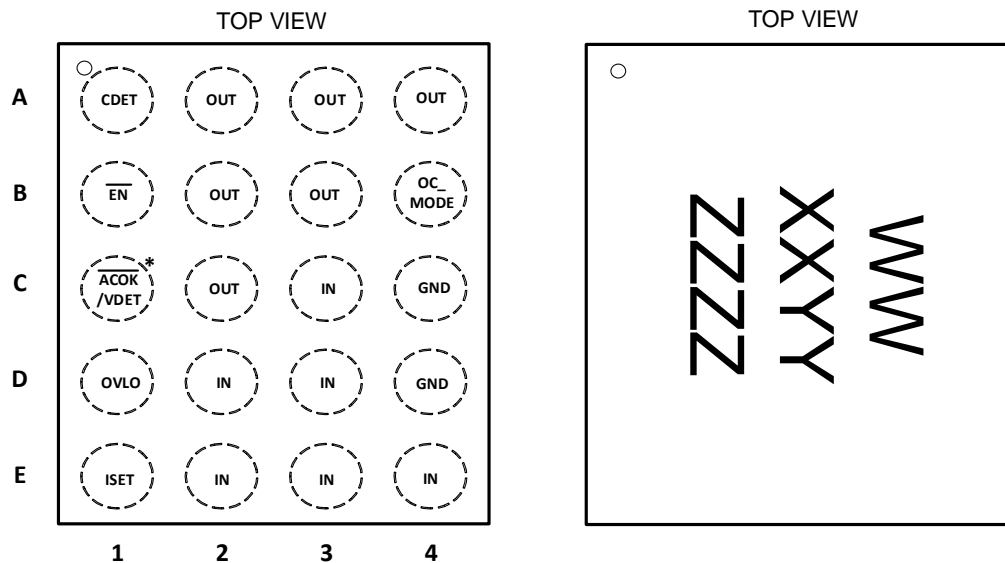

* NOTE: $\overline{\text{ACOK}}$ pin for KTS1693, VDET pin for KTS1693-1

20-Bump 2.160mm x 1.935mm x 0.62mm WLCSP Package

Top Mark

WW = Device ID Code
 XX = Date Code, YY = Assembly Code
 ZZZZ = Serial Number

Absolute Maximum Ratings¹

(T_A = 25°C unless otherwise noted)

Symbol	Description	Value	Units
IN	Input voltage	-0.3 to 30	V
OUT	Output voltage	-0.3 to V _{IN} +0.3	V
OVLO	OVLO Pin	-0.3 to 20	V
CDET, $\overline{\text{EN}}$, ACOK, VDET, ISET, OC_MODE	CDET, $\overline{\text{EN}}$, ACOK, ISET, OC_MODE Pins	-0.3 to 6	V
IN, OUT Current	Continuous Current	8.0	A
	Peak Current (10 μ s)	12.0	A
T _J	Junction Operating Temperature Range	-40 to 150	°C
T _s	Storage Temperature Range	-65 to 150	°C
T _{LEAD}	Maximum Soldering Temperature (at leads, 10 sec)	260	°C

ESD and Surge Protection²

Symbol	Description	Value	Units
V _{ESD_HBM}	JESD22-A114 Human Body Model (all pins)	±2	kV
V _{ESD_CD}	IEC61000-4-2 Contact Discharge (IN pin)	±8	kV
V _{ESD_AGD}	IEC61000-4-2 Air Gap Discharge (IN pin)	±15	kV
V _{ESD_CDM}	CDM (Charged Device Model) (IN pin)	±1	kV
V _{ESD_MM}	MM (Machine Model) (IN pin)	±500	V
V _{SURGE}	IEC61000-4-5 Surge (IN pin to GND)	±110	V

Thermal Capabilities

Symbol	Description	Value	Units
θ_{JA}	Thermal Resistance – Junction to Ambient ³	51.5	°C/W
P _D	Maximum Power Dissipation at T _A ≤ 25°C	2.4	W
$\Delta P_D/\Delta T$	Derating Factor Above T _A = +25°C	19.4	mW/°C

Ordering Information

Part Number	Marking ⁴	Operating Temperature	Package	C1 pin
KTS1693EVB-TR	LVXXYYZZZZ	-40°C to +85°C	WLCSP-20	ACOK
KTS1693EVB-1-TR ⁵	NLXXYYZZZZ			VDET

- Stresses above those listed in Absolute Maximum Ratings may cause permanent damage to the device. Functional operation at conditions other than the operating conditions specified is not implied. Only one Absolute Maximum rating should be applied at any one time.
- ESD and Surge Ratings conform to JEDEC and IEC industry standards. Surge ratings apply with chip enabled, disabled, or unpowered. Surge bias conditions are IN = 0/5V and R_{LOAD} = 100 Ω ; performance degrades marginally at higher voltages, loads and ambient temperature.
- Junction to Ambient thermal resistance is highly dependent on PCB layout. Values are based on thermal properties of the device when soldered to an EV board.
- “WWXXYYZZZZ” is the device ID code, date code, assembly code and serial number.
- Contact your nearest sales office for availability.

Electrical Characteristics⁶

Unless otherwise noted, the *Min* and *Max* specs are applied over the full operation temperature range of -40°C to +85°C, while *Typ* values are specified at room temperature $T_A = 25^\circ\text{C}$ at $V_{IN} = 5.0\text{V}$, $I_{IN} \leq 6\text{A}$.

Symbol	Description	Conditions	Min	Typ	Max	Units
INPUT CLAMP						
V_{IN_CLAMP}	Input clamp voltage	$I_{IN} = 10\text{mA}$, $T_A = +25^\circ\text{C}$		32		V
I_{IN}	Input supply current	$V_{IN} = 5\text{V}$, $V_{IN} < V_{OVLO}$, No Load		140	180	μA
V_{IN_UVLO}	Under-voltage lockout threshold	V_{IN} rising	2.1	2.4	2.7	V
V_{UVLO_HYST}	Under-voltage lockout hysteresis			0.1		V
OVP						
V_{IN_OVLO}	Internal overvoltage trip level	V_{IN} rising	5.77	5.95	6.13	V
$V_{IN_OVLO_HYS}$	OVLO Hysteresis	V_{IN} falling		0.1		V
V_{OVLO_TH}	OVLO preset threshold range		1.162	1.20	1.238	V
	Adjustable OVLO threshold range		4		22	V
V_{OVLO_SEL}	External OVLO select threshold		0.2	0.25	0.3	V
$R_{DS(ON)}$	Switch On-Resistance	$V_{IN} = 5\text{V}$, $I_{IN} = 1.0\text{A}$, $T_A = +25^\circ\text{C}$		9	13	m Ω
I_{OVLO}	OVLO input leakage current	$V_{OVLO} = V_{OVLO_TH}$	-100		100	nA
OCP						
I_{OCP3A}	Input Over-Current Protection threshold(3A)	$R_{ISET} = 2.94\text{k}\Omega$, or $50\text{k}\Omega \leq R_{ISET} \leq 100\text{k}\Omega$, $V_{IN} = 5\text{V}$, $T_A = 0^\circ\text{C}$ to $+70^\circ\text{C}$	3.1	3.4	3.7	A
I_{OCP5A}	Input Over-Current Protection threshold(5A)	$R_{ISET} = 1.79\text{k}\Omega$, or $200\text{k}\Omega \leq R_{ISET} \leq 300\text{k}\Omega$, $V_{IN} = 5\text{V}$, $T_A = 0^\circ\text{C}$ to $+70^\circ\text{C}$	5.1	5.6	6.1	A
I_{LIM}	Minimum Current Limit	$R_{ISET} = 10\text{k}\Omega$, $V_{IN} = 5\text{V}$, $T_A = 0^\circ\text{C}$ to $+70^\circ\text{C}$	0.9	1	1.1	A
CDET						
I_{IN_TH}	Current Detection Threshold	I_{OUT} falling		50		mA
V_{CDET}	CDET output low voltage	$V_{I/O} = 3.3\text{V}$, $I_{SINK} = 1\text{mA}$			0.4	V
V_{CDET_LEAK}	CDET leakage current	$V_{I/O} = 3.3\text{V}$, CDET de-asserted	-1		1	μA
EN, OC_MODE						
V_{IH}	Input Logic High Threshold	$V_{IN} = 2.5\text{V}$ to V_{OVLO}	0.95			V
V_{IL}	Input Logic Low Threshold	$V_{IN} = 2.5\text{V}$ to V_{OVLO}			0.3	V
POWER GOOD						
V_{FAULT}	$\overline{\text{ACOK}}$ output low voltage	$V_{I/O} = 3.3\text{V}$, $I_{SINK} = 1\text{mA}$			0.4	V
$V_{\overline{\text{ACOK}}_LEAK}$	$\overline{\text{ACOK}}$ leakage current	$V_{I/O} = 3.3\text{V}$, $\overline{\text{ACOK}}$ de-asserted	-1		1	μA
VDET (Only for KTS1693-1)						
R_{DET}	VDET Switch On-resistance			40		Ω
V_{DET_OUT}	VDET clamp voltage	$V_{IN} = 20\text{V}$, $I_{VDET} = 1\text{mA}$	4.5	5.0	5.5	V
I_{DET_MAX}	VDET Output Current				3	mA

6. KTS1693 is guaranteed to meet performance specifications over the -40°C to +85°C operating temperature range by design, characterization and correlation with statistical process controls.

Electrical Characteristics⁷

Unless otherwise noted, the *Min* and *Max* specs are applied over the full operation temperature range of -40°C to +85°C, while *Typ* values are specified at room temperature $T_A = 25^\circ\text{C}$ at $V_{IN} = 5.0\text{V}$, $I_{IN} \leq 6\text{A}$.

Symbol	Description	Conditions	Min	Typ	Max	Units
TIMING – Figure 1						
t_{DEB}	Debounce time	Time from $2.5\text{V} < V_{IN} < V_{IN_OVLO}$ to V_{OUT} start rising		0.7		ms
t_{ON}	Switch soft start turn-on time	$V_{IN} = 5\text{V}$, $R_L = 100\Omega$, $C_{LOAD} = 100\mu\text{F}$, $R_{ISET} = 10\text{k}\Omega$, V_{OUT} from 10% V_{IN} to 90% V_{IN}		2		ms
t_{OFF}	Switch turn-off time	$V_{IN} > V_{IN_OVLO}$ to V_{OUT} stop rising, $R_L = 100\Omega$, V_{IN} rising at $2\text{V}/\mu\text{s}$		100		ns
t_{OC}	Over-current response time	$V_{IN} = 5\text{V}$, $I_{IN} >$ Over-Current Protection threshold		5		μs
t_{BLANK}	$\overline{\text{ACOK}}$ Blanking Time	Time after OCP triggered, $\text{OC_MODE} = \text{LOW}$		8		ms
t_{OCP_DEB}	OCP Debounce time	Time after OCP triggered, $\text{OC_MODE} = \text{LOW}$	5	8	10	ms
t_{RSTRT}	Auto re-start time	$\text{OC_MODE} = \text{HIGH}$		200		ms
THERMAL SHUTDOWN						
t_{J-TH}	IC junction thermal shutdown threshold			140		$^\circ\text{C}$
	IC junction thermal shutdown hysteresis			20		$^\circ\text{C}$

7. KTS1693 is guaranteed to meet performance specifications over the -40°C to +85°C operating temperature range by design, characterization and correlation with statistical process controls.

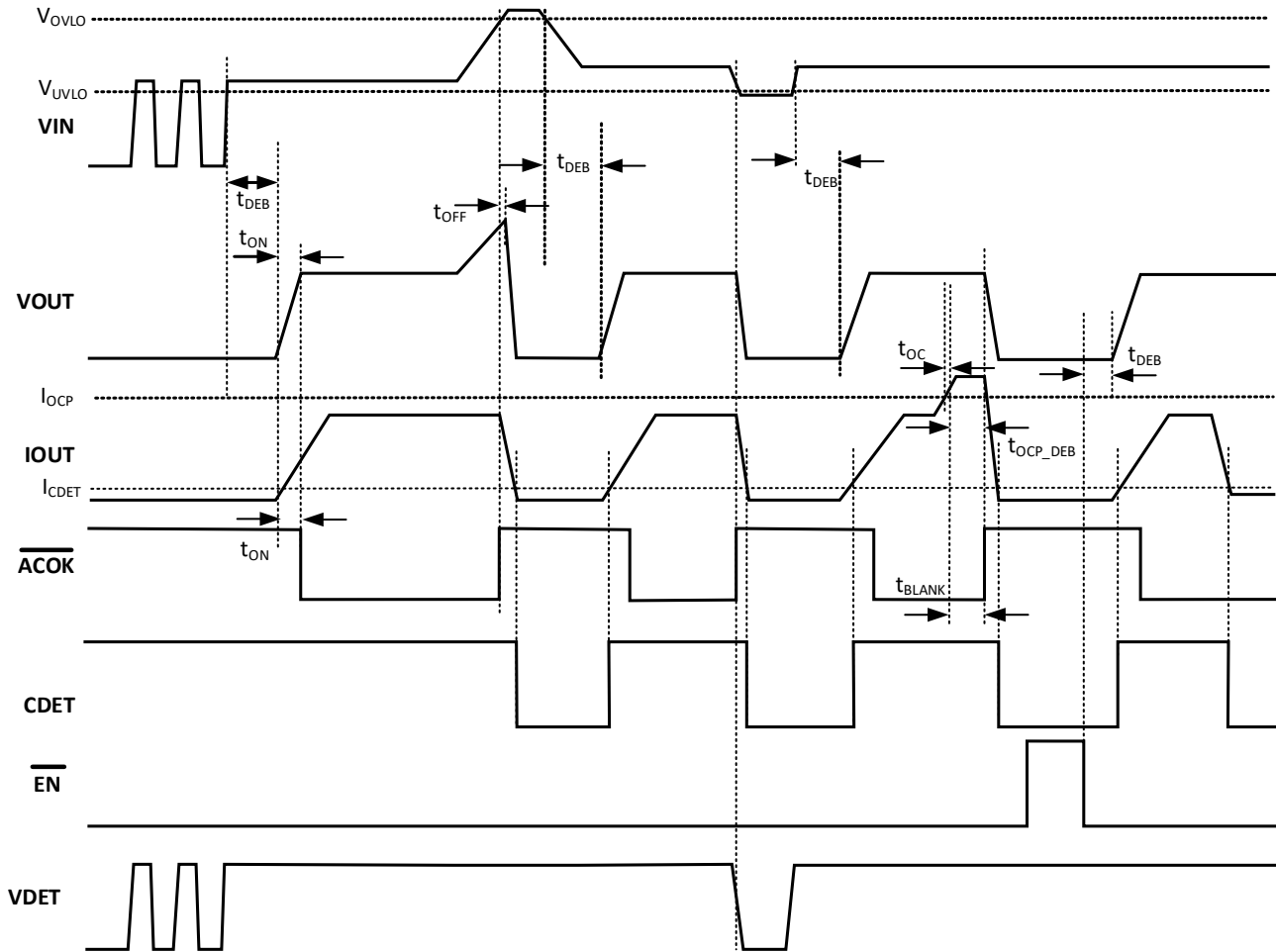

* NOTE: WAVEFORMS ARE NOT TO SCALE

\overline{ACOK} pin for KTS1693, V_{DET} pin for KTS1693-1

Figure 1. Timing Diagram (OC_MODE = LOW)

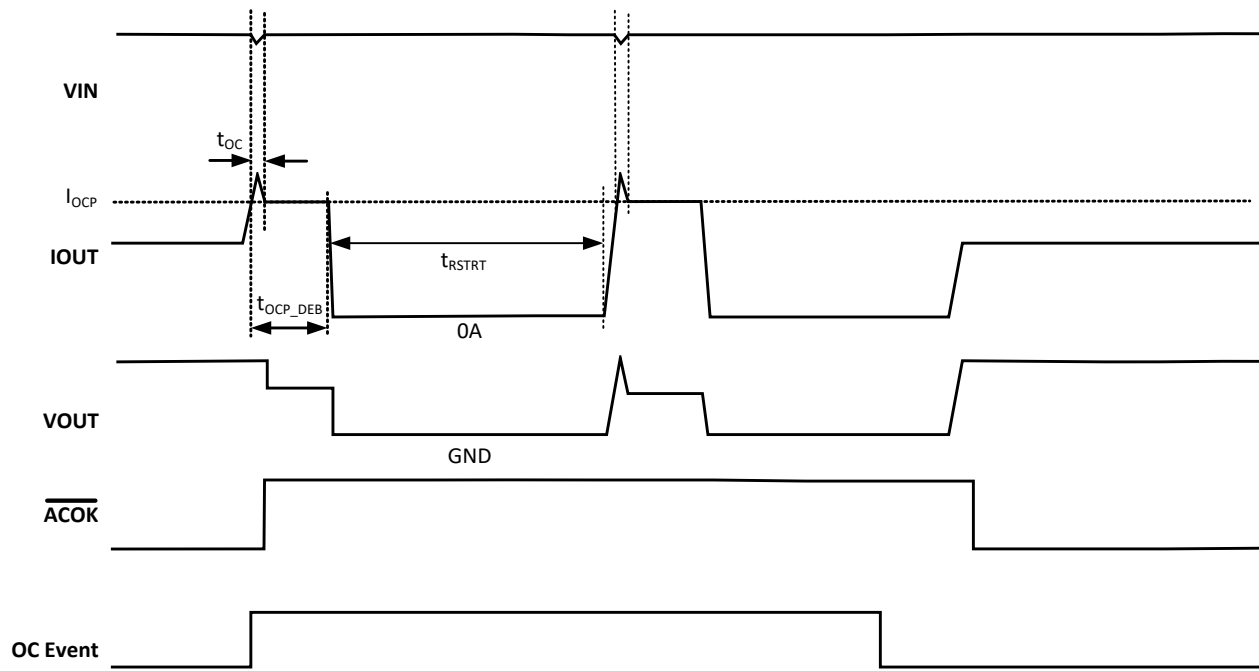

* NOTE: WAVEFORMS ARE NOT TO SCALE

Figure 2. Timing Diagram (OC_MODE = HIGH)

Typical Characteristics

$V_{IN} = 5V$, $C_{IN} = 0.1\mu F$, $C_{OUT} = 1\mu F$, $R_{ISET} = 5k\Omega$, OVLO pin = GND, OC_MODE = LOW, $\overline{EN} = LOW$, $T_A = 25^\circ C$ unless otherwise specified.

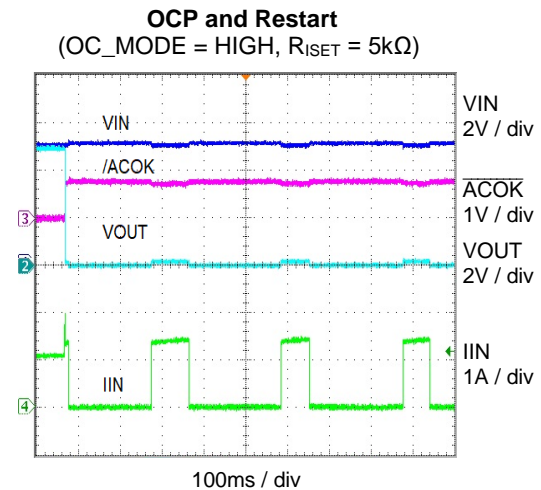
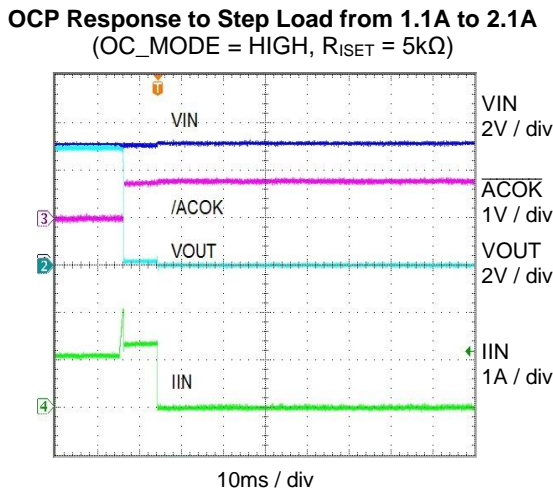
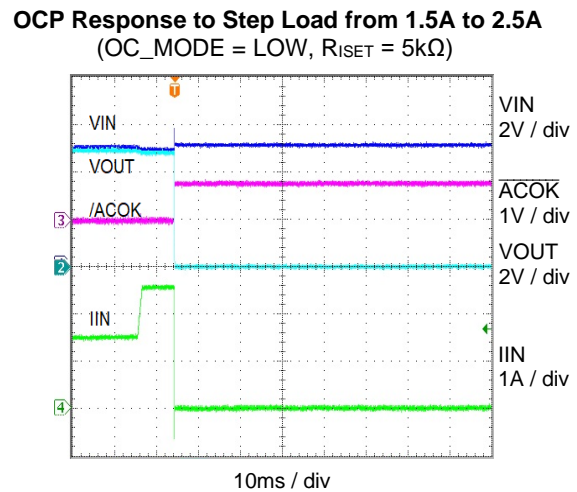
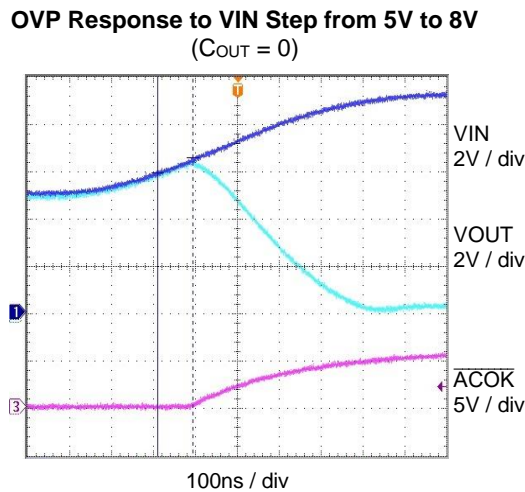
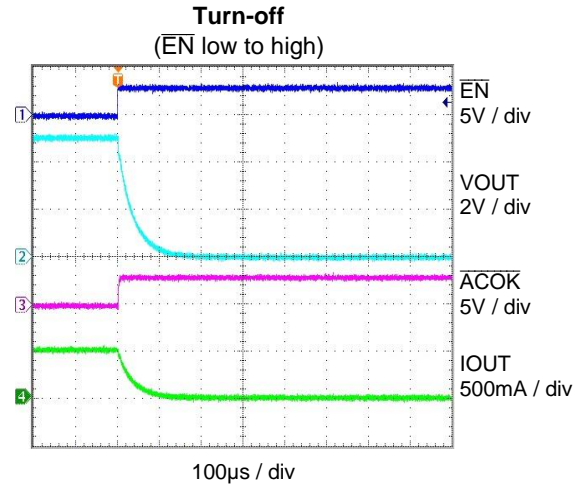
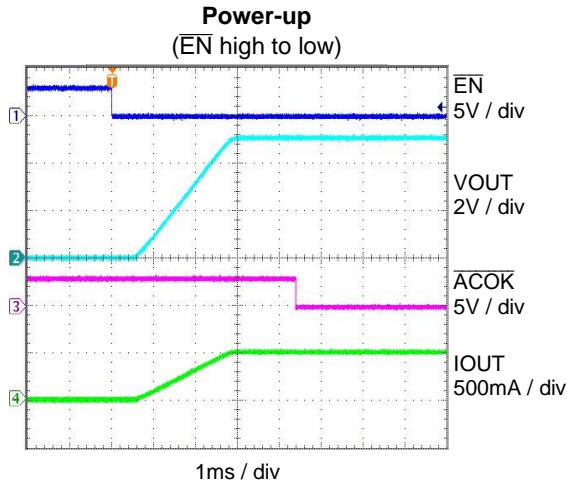

Typical Characteristics

$V_{IN} = 5V$, $C_{IN} = 0.1\mu F$, $C_{OUT} = 1\mu F$, $R_{ISET} = 5k\Omega$, OVLO pin = GND, OC_MODE = LOW, $\overline{EN} = LOW$, $T_A = 25^\circ C$ unless otherwise specified.

Surge Transient +110V

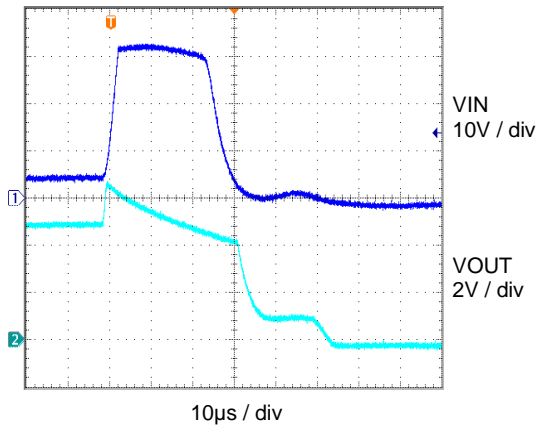

Surge Transient -110V

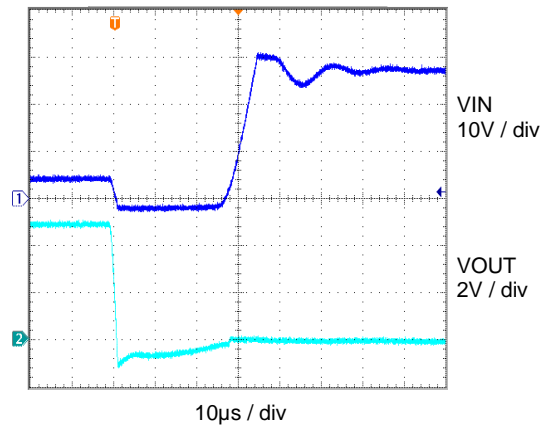

**CDET Response to VOUT Load Step
(0 to 100mA)**

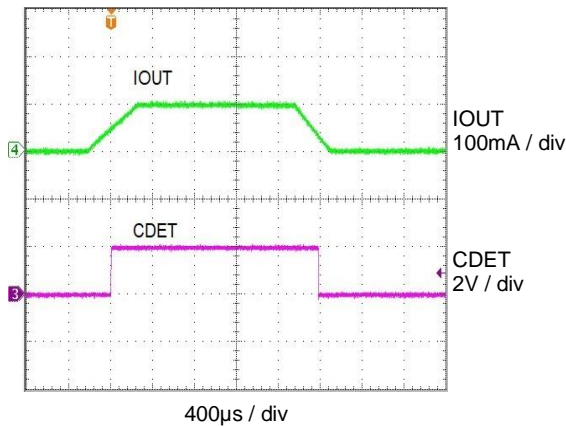

Functional Block Diagram

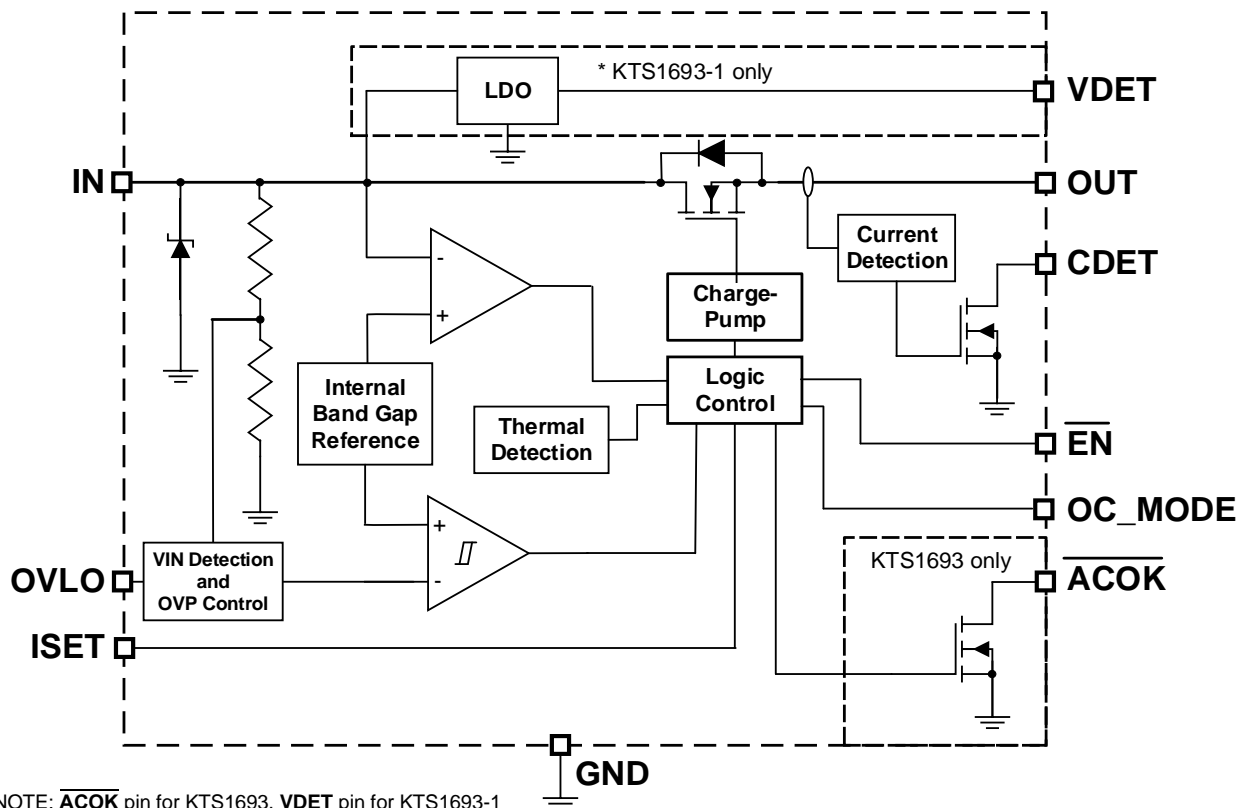

Functional Description

The KTS1693 is inserted between the power supply or charger source (such like USB Type C port) and the load to be protected. The KTS1693 consists of a low resistance, overvoltage protection (OVP), and over-current protection (OCP) switch, with under-voltage lockout protection (UVLO), overvoltage monitor and protection (OVLO), current detection and fault output flag.

The KTS1693 overvoltage protection device features a low on-resistance ($R_{DS(ON)}$) internal FET and protect low-voltage systems against voltage faults up to +30VDC. An internal clamp also protects the devices from surges up to $\pm 110V$. If the input voltage exceeds the overvoltage threshold, the internal FET is turned-off to prevent damage to the protected components. The 0.7ms debounce time built into the device prevents false turn-on of the internal FET during startup.

In normal operation the OVP switch acts as a slew-rate controlled load switch, connecting and disconnecting the power supply from IN to OUT. A low resistance N-Ch MOSFET is used to minimize the voltage drop between the voltage source and the load thereby minimizing the power dissipation.

When the voltage on the input exceeds the programmed overvoltage trip point, the device immediately turns-off the internal OVP switch disconnecting the load from the abnormal voltage, preventing damage to any downstream components.

In the event that the power dissipation causes the chip temperature to exceed its maximum temperature setting, the KTS1693 will switch-off protecting the device. Once the chip temperature has cooled below the hysteresis temperature, KTS1693 turn-on will re-initiate. Should the over-temperature condition persist, then KTS1693 will continue to thermally cycle on and off, until such time as the system shuts it down.

The KTS1693 has a Power Good flag ($\overline{\text{ACOK}}$) pin to indicate that the input voltage is above UVLO voltage, the supply is stable and there are no faults. In the case of an UVLO, OVLO, OCP or OTP condition the $\overline{\text{ACOK}}$ Flag will de-assert, allowing the Flag voltage to go High, therefore alerting the system. If an input overvoltage condition exists at the time of the device enable, then the OVP switch will remain OFF and $\overline{\text{ACOK}}$ is always high.

For KTS1693-1, it has a VDET pin instead of ($\overline{\text{ACOK}}$) pin for VBUS detection function, and provides a “clamped” output voltage, whenever a voltage appears on VIN, even if the power switch is off due to an overvoltage condition.

UVLO (Under-Voltage Lockout)

The device has a built-in under voltage lock out (UVLO) circuit. When V_{IN} is rising, the output remains disconnected from the input until VIN voltage is above 2.3V (nominal). This circuit has a 100mV hysteresis to provide noise immunity to transient conditions.

OVLO (Overvoltage Lockout)

The KTS1693 can be used as both a fixed and adjustable OVP device. If OVLO pin is tied to GND, the OVP trip point is fixed to 5.95V. Connecting a resistive divider between IN and GND to the OVLO pin, the OVP trip point can be adjusted between 4V and 22V.

Internal MOSFET Switch

The KTS1693 incorporates an internal FET with a $9\text{m}\Omega$ (typ) $R_{\text{DS(on)}}$. In normal operation mode, the $\overline{\text{EN}}$ input must be set to the logic low state. The FET is internally driven by a charge pump that generates a necessary gate voltage above IN.

Over-Current Protection at Normal Mode

The KTS1693 includes over-current protection. Below equation shows the relationship between R_{ISET} and I_{OCP} :

$$R_{\text{ISET}} = 10000 / I_{\text{OCP}}$$

If $\text{OC_MODE} = \text{LOW}$ and the switch current exceeds the current set by the resistor R_{ISET} , then the device will turn-off the switch after 8ms de-bounce time (switch will still fully turn-on during this 8ms time). If $\text{OC_MODE} = \text{HIGH}$ and the switch current exceeds the current set by the resistor R_{ISET} , then the device will enter into current limit mode for typ. 8ms and then turn-off the switch. The relationship between the resistor and the over-current protection is shown in Figure 3.

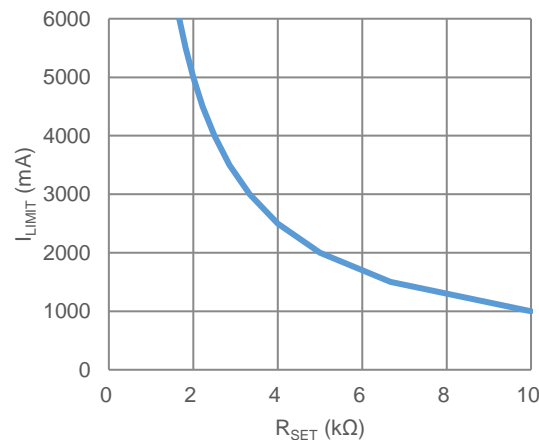

Figure 3. Over-Current Protection vs. ISET Resistor

When $\text{OC_MODE} = \text{LOW}$, if V_{IN} is present after OCP triggers and switch is off, in order to turn the switch back on, the $\overline{\text{EN}}$ pin must be pulled high then low to perform the switch restart.

Note, if $R_{\text{ISET}} = 0$, then the OCP function will be disabled, but the short-circuit protection is still functional.

Table 1. RISET vs. IOCP Look-up Table

R _{ISET} (kΩ)	I _{OCP} (mA)		
	Min.	Typ.	Max.
10.00	910	1000	1090
9.09	1001	1100	1199
8.33	1092	1200	1308
7.69	1183	1300	1417
7.14	1274	1400	1526
6.67	1365	1500	1635
6.25	1456	1600	1744
5.88	1547	1700	1853
5.56	1638	1800	1962
5.26	1729	1900	2071
5.00	1820	2000	2180
4.76	1911	2100	2289
4.55	2002	2200	2398
4.35	2093	2300	2507
4.17	2184	2400	2616
4.00	2275	2500	2725
3.85	2366	2600	2834
3.70	2457	2700	2943
3.57	2548	2800	3052
3.45	2639	2900	3161
3.33	2730	3000	3270
3.23	2821	3100	3379
3.13	2912	3200	3488
3.03	3003	3300	3597
2.94	3094	3400	3706
2.86	3185	3500	3815
2.78	3276	3600	3924
2.70	3367	3700	4033
2.63	3458	3800	4142
2.56	3549	3900	4251
2.50	3640	4000	4360
2.44	3731	4100	4469
2.38	3822	4200	4578
2.33	3913	4300	4687
2.27	4004	4400	4796
2.22	4095	4500	4905
2.17	4186	4600	5014
2.13	4277	4700	5123
2.08	4368	4800	5232
2.04	4459	4900	5341
2.00	4550	5000	5450
1.96	4641	5100	5559
1.92	4732	5200	5668
1.89	4823	5300	5777
1.85	4914	5400	5886
1.82	5005	5500	5995
1.79	5096	5600	6104
1.75	5187	5700	6213
1.72	5278	5800	6322
1.69	5369	5900	6431
1.67	5460	6000	6540

In addition to the above equation, KTS1693 also has an easy setting table of R_{ISET} for commonly used OCP values which are mainly for Type C port 3A/5A application. For the range $50k\Omega \leq R_{ISET} \leq 100k\Omega$, the I_{OCP} is set to I_{OCP3A} , which means the input Over-Current Protection threshold is min. 3.1A, typ. 3.4A and max. 3.7A. For the range $200k\Omega \leq R_{ISET} \leq 300k\Omega$, the I_{OCP} is set to I_{OCP5A} , which means the input Over-Current Protection threshold is min. 5.1A, typ. 5.6A and max. 6.1A. For the range $R_{ISET} \geq 500k\Omega$, the OCP function is disabled, but the short circuit protection is still functional.

Table 2. Easy Setting Table for Over-Current Protection vs. ISET Resistor

R_{ISET} (k Ω)	50~100	200~300	≥ 500
I_{OCP} (A)	I_{OCP3A} min. 3.1A, typ. 3.4A, max. 3.7A	I_{OCP5A} min. 5.1A, typ. 5.6A, max. 6.1A	Disabled (No limit)

Over-Current Limit Protection During Soft Start Mode

The KTS1693 also supports over-current limit protection function during soft-start mode. Unlike normal mode, the main switch does not turn off during soft-start mode in order to make sure that C_{OUT} can be fully charged. The soft-start will be complete when both two conditions are met:

- 1) $V(IN-OUT) < 100mV$.
- 2) $V(GATE,OUT) > 3V$.

Once soft-start is completed, KTS1693 enters normal OCP mode in which if the current is higher than the threshold for 8ms, then the internal power switch shuts down quickly. This function allows KTS1693 to safely charge large loads with C_{OUT} up to 500 μ F without turning off the power switch.

Short-Circuit Protection

The KTS1693 includes short-circuit protection in addition of over-current protection. When the slew-rate of input current is very fast, for eg. faster than 1A/ μ s few μ s and the peak input current is higher than 10A, by checking the voltage gap between IN and OUT pin when the switch is on, if $V_{IN} - V_{OUT} > 0.15V$, KTS1693 will treat this as an unusual short-circuit event and turn-off the main switch immediately. This is faster than only detecting the OCP threshold or waiting for thermal shutdown so it can protect the device from damage during V_{OUT} short to GND event.

Note, if V_{OUT} short to GND happens during or before soft-start stage, KTS1693 will initially work in current limit mode. This will cause IC to enter thermal shutdown due to the IC high power dissipation. Then IC will restart after the die temperature decreases by about 20°C. The IC will then thermally oscillate on and off until the fault condition is removed. This is so called thermal hiccup mode.

CDET Output

The CDET output is an active-high open-drain switch current detection reporting output to indicate that a charging adapter is connected. A pull-up resistor should be connected from CDET to the logic I/O voltage of the system. CDET is normally high indicating that the current pass to indicate that a charging adapter is connected through the switch is higher than 50mA(typ). Only when the switch current is less than 50mA(typ) will the CDET pin be pulled to ground, indicating there is only small current (or “no current”) pass through the switch. When $V_{IN} < V_{IN_UVLO}$ (2.3V), CDET output is pulled high to the I/O voltage. CDET pin can be floating if it is not used.

ACOK Output

The ACOK output is an active-low open drain power good reporting output and is asserted when the input voltage is above the UVLO threshold and the supply is stable. A pull-up resistor should be connected from the ACOK output to the logic I/O voltage of the system. The \overline{ACOK} pin can also be used as a fault indicator as an UVLO, OVLO, OCP or OTP fault will deassert the flag allowing the output voltage to be pulled high. The \overline{ACOK} pin can be left floating if not used.

Protected Bus Voltage(VDET Output)

The KTS1693-1 passes a protected IN voltage through to VDET pin which replaces \overline{ACOK} pin. The VDET pin can provide up to 3mA of DC current. VDET contains an internal 5.0V clamp to protect devices connected to VDET, while still allowing the devices to operate from the VDET voltage. The voltage at VDET is not present while the device is in thermal shutdown or IN is lower than the input operating range.

Thermal Protection

The internal FET turns-off when the junction temperature exceeds +140°C (typ). The device exits thermal shutdown after the junction temperature cools down by 20°C (typ).

Application Information

Input Capacitor

A 0.1µF or larger capacitor is typically recommended for CIN. CIN should be located as close as possible to the device IN pin. There is no specific capacitor equivalent series resistance (ESR) requirement for CIN. For higher current operation, ceramic capacitors are recommended for CIN due to their inherent capability over tantalum capacitors to withstand input current surges from low impedance sources such as batteries in portable devices. Capacitors are typically manufactured in different voltage ratings. If the maximum possible surge voltage is known, select capacitors with a voltage rating at least 5V higher than the maximum possible surge voltage. 50V rated capacitors are generally good for most OVP applications to prevent any surge voltage.

Output Capacitor

In order to insure stability while switch is active, a small output capacitance of approximately 1µF is required at the output. Likewise, with the output capacitor, there is no specific capacitor ESR requirement. If desired, COUT may be increased to accommodate any load transient condition.

VDET Capacitor

On the KTS1693-1, a small bypass capacitor of approximately 1µF is required at the VDET output.

External OVLO Adjustment

If the OVLO pin is connected to ground, the internal OVLO comparator uses the internally set OVLO threshold value.

The adjustable threshold uses a 1.20V (typical) overvoltage trip threshold on the OVLO pin. With a resistor divider on the OVLO pin from IN to GND, the overvoltage protection point of IN can be adjusted between 4V and 22V. Once the OVLO pin voltage exceeds the OVLO select voltage, V_{OVLO_SELECT} (0.25V typical), the comparator reads the OVLO pin voltage (a fraction of IN) set by the external resistor divider (R1, R2).

$R_1 = 1M\Omega$ is a good starting value for minimum current consumption. Since V_{IN_OVLO} , V_{OVLO_THRESH} , and R_1 are known, R_2 can be calculated from the following formula:

$$V_{IN_OVLO} = V_{OVLO_TH} \times \left(1 + \frac{R_1}{R_2}\right)$$

This external resistor-divider is completely independent from the internal resistor-divider.

USB On-The-Go (OTG) Operation

When used in an OTG application the KTS1693 can provide power from OUT to IN. Initially, the OTG voltage applied at OUT will forward bias the power switch bulk diode and present a voltage drop of approximately 0.7V between OUT and IN. The maximum current in this mode is limited by the thermal performance of the device and at an ambient temperature of 25°C

$$I_{MAX} = 2.4W/0.7V = 3.4 A$$

This is purely a transitional condition as once the voltage at IN exceeds the UVLO voltage of 2.3V and the debounce time of 0.7ms has elapsed, the main power switch will turn fully ON, significantly reducing the voltage drop from OUT to IN.

Packaging Information

WLCSP45-20 (1.935mm x 2.160mm x 0.62mm)

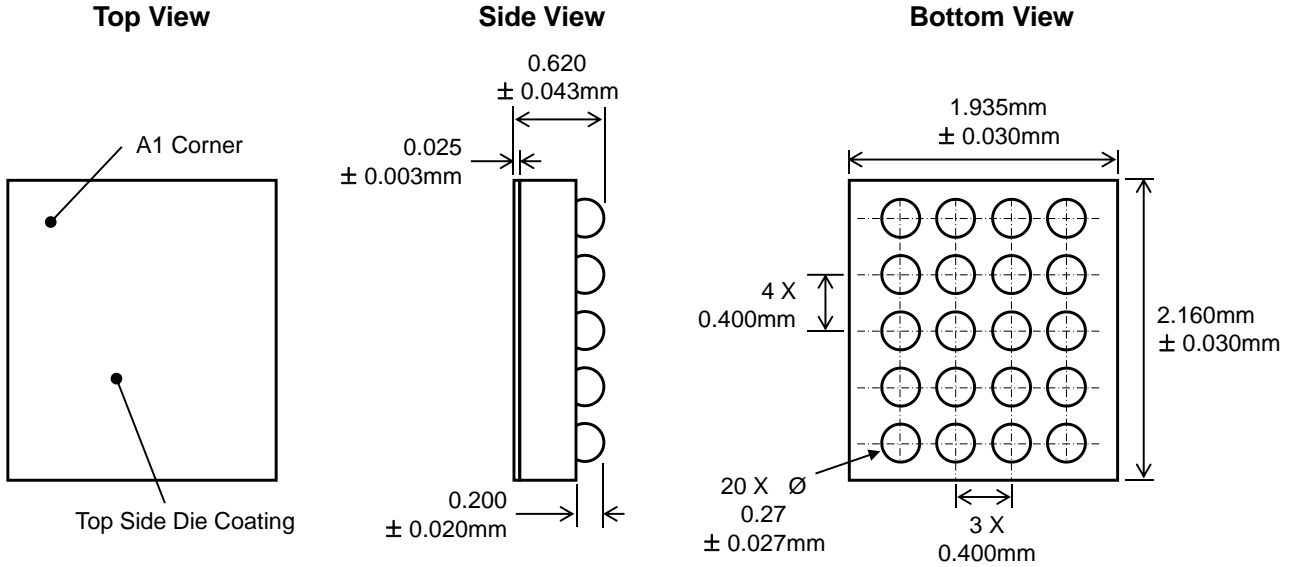

Recommended Footprint

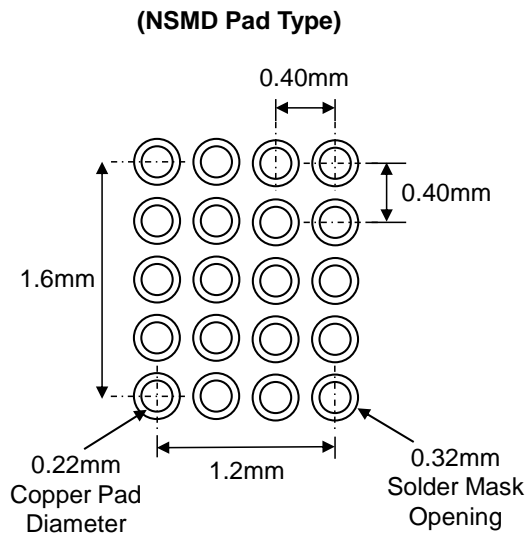

* Dimensions are in millimeters.

Tape and Reel Specifications

Reel Dimensions

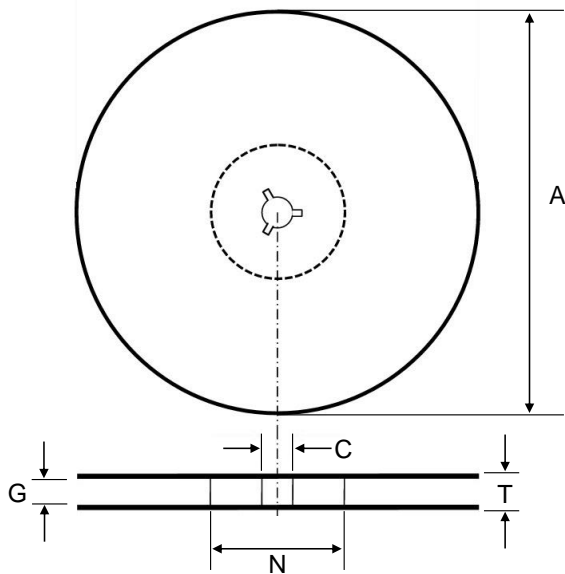

Dimension	mm		
	Min.	Typ.	Max.
A	178.0	180.0	182.0
C	12.8	13.0	13.5
G	9.4	9.6	9.8
N	54.0	54.0	57.0
T	12.2	12.4	12.6

Tape Dimensions

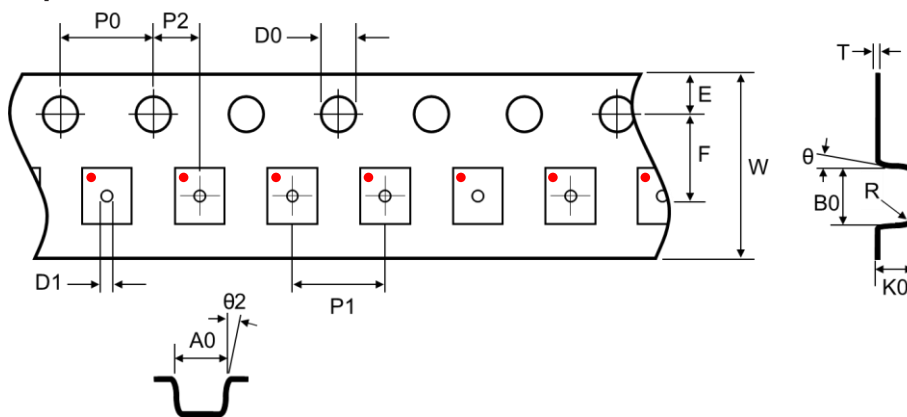

Dimension	mm		
	Min.	Typ.	Max.
A0	2.00	2.05	2.10
B0	2.23	2.28	2.31
K0	0.72	0.77	0.82
P0	3.9	4.0	4.1
P1	3.9	4.0	4.1
P2	1.95	2.00	2.05
D0	1.50	1.55	1.60
D1	0.45	0.50	0.55
E	1.65	1.75	1.85
F	3.45	3.50	3.55
10P0	39.8	40	40.2
W	7.9	8.0	8.3
T	0.15	0.20	0.25
Theta	0°		5°
Theta2	0°		5°

Kinetic Technologies cannot assume responsibility for use of any circuitry other than circuitry entirely embodied in a Kinetic Technologies product. No intellectual property or circuit patent licenses are implied. Kinetic Technologies reserves the right to change the circuitry and specifications without notice at any time.