

FO-WLP55-25

Package Code: WAA

FO_WLP55-25 (2.00mm x 2.00mm x 0.800mm)

Top View

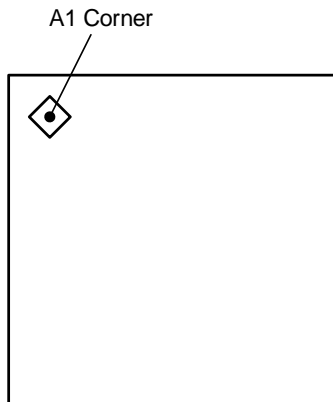

Side View

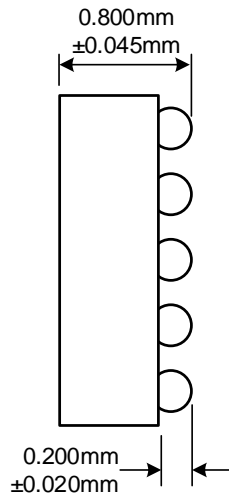

Bottom View

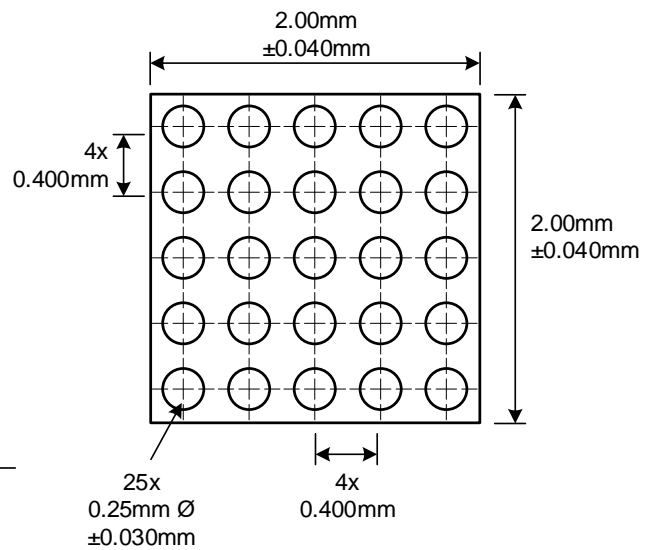

Recommended Footprint

(NSMD Pad Type)

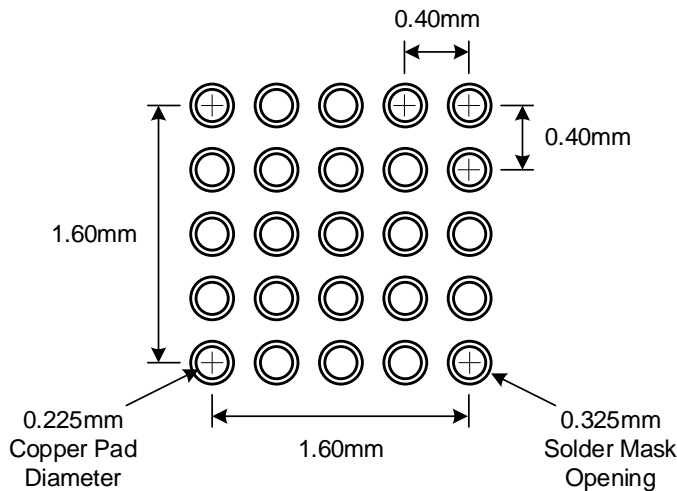

Kinetic Technologies cannot assume responsibility for use of any circuitry other than circuitry entirely embodied in a Kinetic Technologies product. No intellectual property or circuit patent licenses are implied. Kinetic Technologies reserves the right to change the circuitry and specifications without notice at any time.