

2MHz, 1.5A Flash LED Driver with Low-Vin Protection in TDFN

Features

- Drive up to 1.5A flash current
- Programmable threshold low-voltage input protection
- High efficiency converter (up to 90%)
- Input voltage range: 2.7V to 5.5V
- 2MHz step-up converter
- Very small inductor: 1.0 μ H to 2.2 μ H
- Very small load capacitor: 4.7 μ F to 10 μ F
- ExpressWire™ digital control enables and programs flash and movie current in 16 steps
- External resistor sets maximum flash current
- Integrated thermal regulation control
- 2mA LED shorting test current and 1.7V forward voltage threshold
- LED open/short protection
- Over-voltage protection
- Cycle-by-cycle inductor current limit
- Programmable flash timeout protection
- 0.1 μ A shutdown current
- Pb-free Package: TDFN2x3-14
- -40°C to +85°C Temperature Range

Applications

- Mobile Phones
- Smart Phones and PDAs
- Digital Still Cameras

Brief Description

KTD2692 is the ideal power solution for high-power flash LEDs used with cell phone camera modules or digital still cameras. It is a highly integrated step up DC-DC converter with very high switching frequency, fixed at 2MHz, providing a very small total solution for portable photo flash. KTD2692 uses ExpressWire single-wire programming for maximum flexibility. The maximum flash-mode LED current is set by an external resistor, and the flash-mode and movie-mode currents can be programmed in 16 steps by the ExpressWire interface at CTRL pin. An AUX pin allows highest priority ON/OFF flash mode control. KTD2692 internally monitors the input voltage, disabling LED current when the supply drops below the programmed threshold voltage.

The LED output sink can drive up to 1.5A continuous LED current. Thermal regulation is integrated in flash mode to limit the IC's temperature and continuously provide the maximum allowed output current.

Various protection features are built into KTD2692, including cycle-by-cycle input current limit protection, output over-voltage protection, LED fault (open or short) protection, flash timeout protection and thermal shutdown protection. The leakage current in shutdown mode is 0.1 μ A.

KTD2692 is available in a RoHS and Green compliant 14-lead 2 x 3 x 0.75mm ThinDFN package.

Typical Application

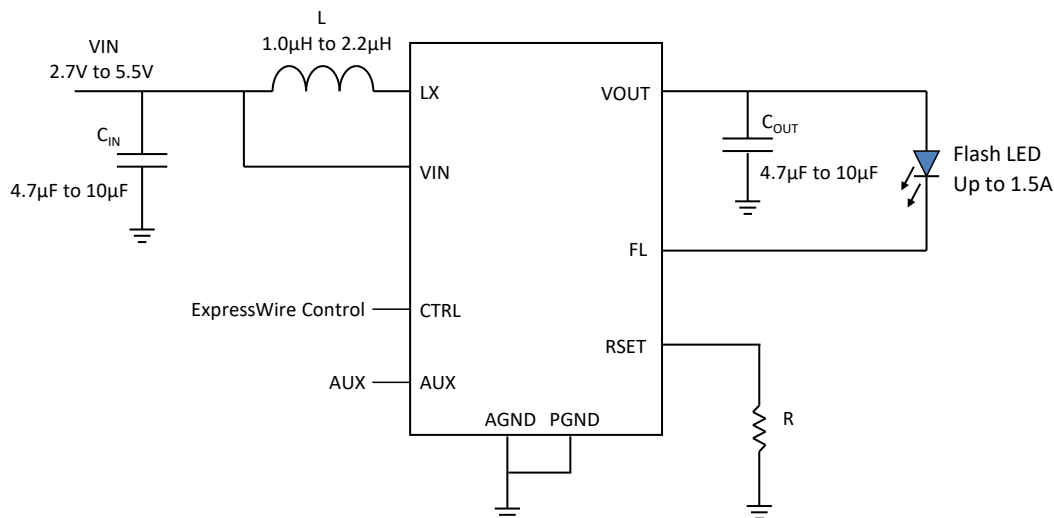

Pin Descriptions

TDFN2x3-14

Pin #	Name	Function
1	AGND	Analog Ground pin
2	CTRL	ExpressWire control pin. Can be used to enable/disable the IC, as well as to program the Movie/Flash mode current, LVP, Flash timeout, and LED on/off control using digital interface. There is an internal 300kΩ pull-down resistor at this pin.
3	FL	Regulated output current sink, up to 1.5A current.
4, 5, 9, 12	NC	No Connection
6	VIN	IC supply voltage
7, 13	PGND	Power Ground pin
8	VOUT	Output voltage pin
10	LX	Converter switching node. The inductor should be connected between Vin and LX.
11	AUX	AUX control pin. If AUX rising edge is detected when IC is enabled, the output current is forced to the Flash mode current set by the programmed setting value and this has a higher priority over CTRL. There is an internal 300kΩ pull-down resistor at this pin.
14	RSET	Flash mode maximum current setting pin. Connect a resistor from RSET to GND.
	MC	Metal chassis. Connect to ground for electrical and thermal usage. MC is internally connected to Analog Ground pin.

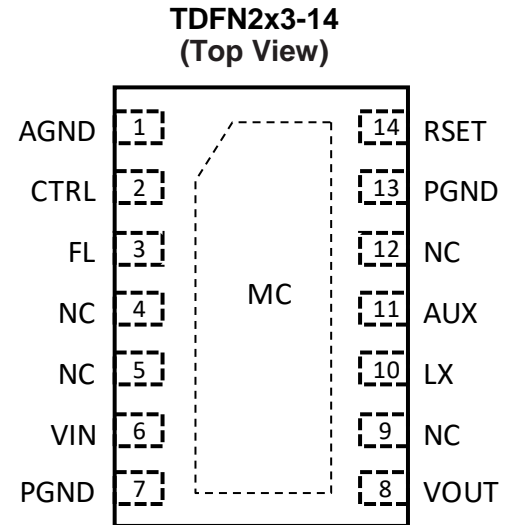

Absolute Maximum Ratings ¹

T_A = 25°C unless otherwise noted.

Symbol	Description	Value	Units
V _{IN} , V _{OUT} , FL	Input voltage, output pins	-0.3 to 6	V
CTRL, AUX, RSET	Control pins	-0.3 to V _{IN} +0.3	V
LX	Switching node	-0.3 to 6.5	V
T _J	Operating Temperature Range	-40 to 150	°C
T _s	Storage Temperature Range	-65 to 150	°C
T _{LEAD}	Maximum Soldering Temperature (at leads, 10 sec)	300	°C

1. Stresses above those listed in Absolute Maximum Ratings may cause permanent damage to the device. Functional operation at conditions other than the operating conditions specified is not implied. Only one Absolute Maximum rating should be applied at any one time.

Thermal Capabilities

Symbol	Description	Value	Units
θ _{JA}	Thermal Resistance – Junction to Ambient ²	78	°C/W
P _D	Maximum Power Dissipation at T _A ≤ 25°C	1.28	W
ΔP _D /ΔT	Derating Factor Above T _A = 25°C	-12.8	mW/°C

2. Junction to Ambient thermal resistance is highly dependent on PCB layout. Values are based on thermal properties of the device when soldered to an EV board.

Recommended Operating Range

Description	Value
V _{IN} , V _{OUT} , and FL Voltages	2.7V to 5.5V
LX Voltage	Up to 6V

Ordering Information

Part Number	Marking ³	Operating Temperature	Package
KTD2692EJH-TR	ECYYZ	-40°C to +85°C	TDFN23-14

3. "YYZ" is the date code and assembly code.

Electrical Characteristics⁴

Unless otherwise noted, the *Min* and *Max* specs are applied over the full operation temperature range of -40°C to $+85^{\circ}\text{C}$, while *Typ* values are specified at 25°C room temperature. $V_{\text{IN}} = 4\text{V}$.

Symbol	Description	Conditions	Min	Typ	Max	Units
IC Supply						
V_{IN}	Input operating range		2.7		5.5	V
I_{Q}	IC operating current	Not switching		1.2	2.4	mA
	IC operating current	Switching		1.4	2.8	mA
I_{SHDN}	VIN pin shutdown current	CTRL = GND		0.1	1	μA
Step-Up Converter						
I_{LIM}	Peak NMOS current limit			3.5		A
F_{SW}	Oscillator frequency			2		MHz
D_{MAX}	Maximum duty cycle		66	73		%
V_{OVP}	Internal OV threshold of VOUT			5.3		V
V_{LVP}	Low Vin Protection threshold	CTRL = Default, $T_{\text{A}} = 25^{\circ}\text{C}$	3.33	3.5	3.67	V
T_{S}	Flash mode softstart time			60		μs
Current Sink						
I_{D}	Output Current		0		1500	mA
	Output Current Accuracy, Flash Mode	CTRL = Default, $R_{\text{SET}} = 15\text{k}\Omega$, $T_{\text{A}} = 25^{\circ}\text{C}$	950	1000	1050	mA
	Output Current Accuracy, Movie/Torch Mode	CTRL = Default, $R_{\text{SET}} = 15\text{k}\Omega$, $T_{\text{A}} = 25^{\circ}\text{C}$	94	106	118	mA
I_{SHORT}	LED Short Checking Current	LED forward voltage threshold: 1.7V		2		mA
T_{CT}	Flash Timeout Period	CTRL = Default		1049		ms
Control						
$V_{\text{TH-H}}$	CTRL and AUX pin logic high threshold		1.4			V
$V_{\text{TH-L}}$	CTRL and AUX pin logic low threshold				0.4	V
$R_{\text{Pull-down}}$	CTRL and AUX pin internal pull down resistors			300		$\text{k}\Omega$
t_{DS}	Minimum Data Start Time High pulse width timing, CTRL		10			μs
$t_{\text{EOD-H}}$	Minimum End of Data Time High pulse width timing, CTRL		350			μs
$t_{\text{EOD-L}}$	End of Data Time Low pulse width timing, CTRL		2		64	μs
$t_{\text{H-LB}}$	High time low bit, CTRL		2		64	μs
$t_{\text{L-LB}}$	Low time low bit, CTRL	$t_{\text{L-LB}} = 2 \times t_{\text{H-LB}}$	4		128	μs
$t_{\text{H-HB}}$	High time high bit, CTRL	$t_{\text{H-HB}} = 2 \times t_{\text{L-HB}}$	4		128	μs
$t_{\text{L-HB}}$	Low time high bit, CTRL		2		64	μs
t_{RESET}	Minimum Reset Time Low pulse width timing, CTRL		700			μs
Thermal Shutdown						
$t_{\text{J-TH}}$	IC junction thermal shutdown threshold			150		$^{\circ}\text{C}$
	IC junction thermal shutdown hysteresis			20		$^{\circ}\text{C}$

4. KTD2692 is guaranteed to meet performance specifications over the -40°C to $+85^{\circ}\text{C}$ operating temperature range by design, characterization and correlation with statistical process controls.

Typical Characteristics

$V_{IN} = 4.0V$, $L = 1.0\mu H$, $C_{IN} = 2.2\mu F$, $C_{OUT} = 10\mu F$, Temp = 25°C unless otherwise specified.

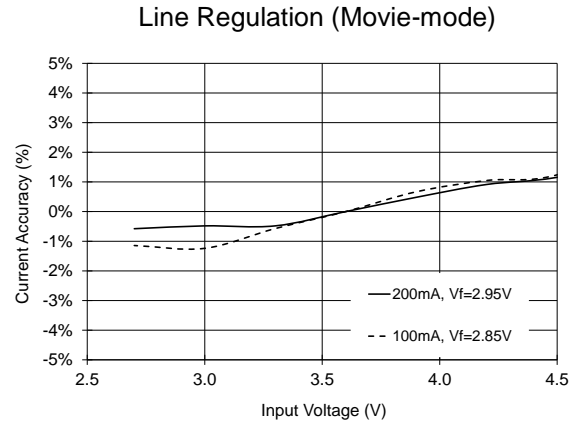
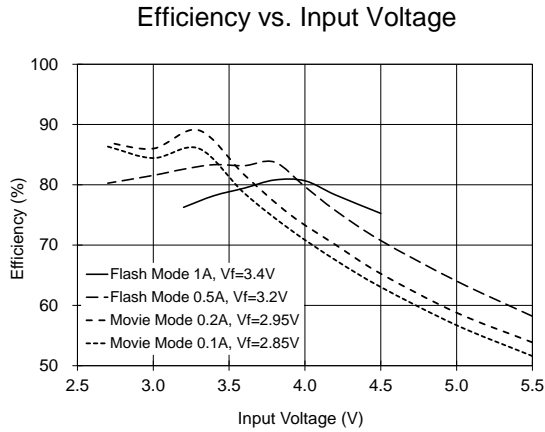

Flash-mode Operating Current (non-switching)

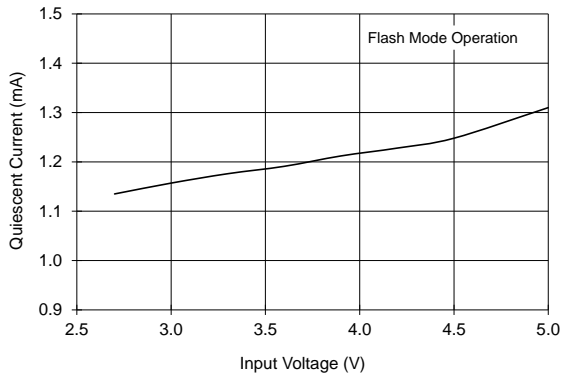

Movie-mode Operating Current

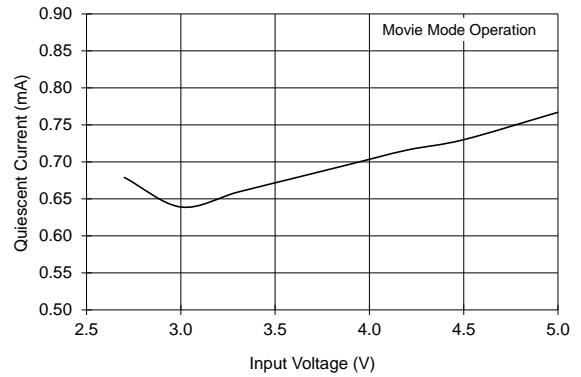

Switching Frequency vs. Input Voltage

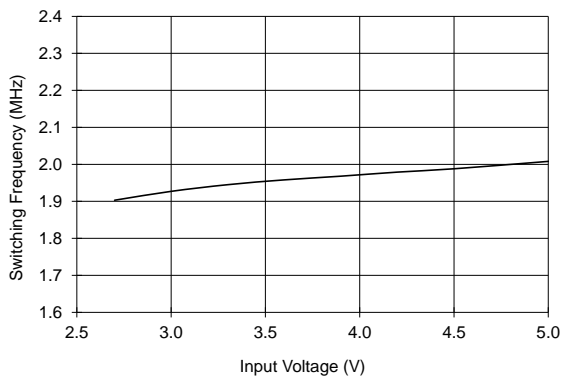

Reset Shutdown Delay vs. Input Voltage

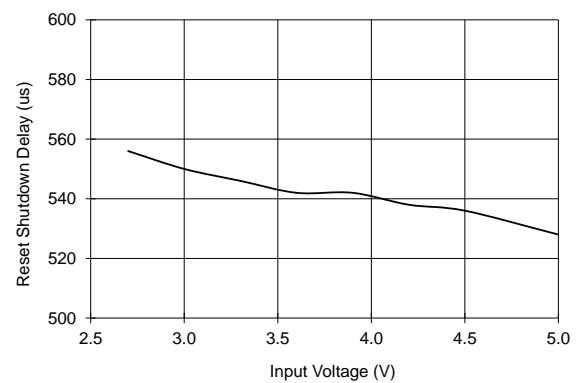

Typical Characteristics (continued)

Timeout Duration vs. Timer Programming Code

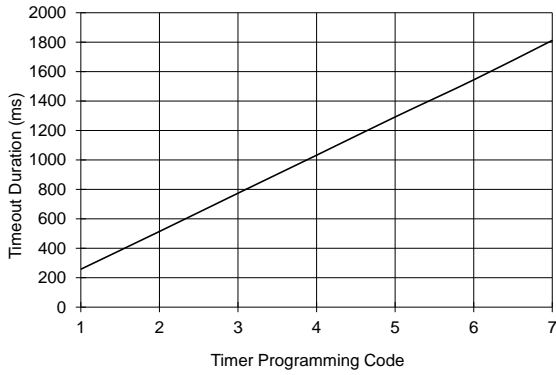

Timeout Duration vs. Input Voltage

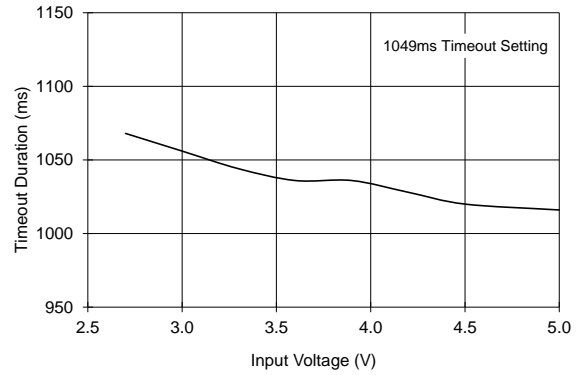

1.5A Flash with AUX (VIN = 3.6V)

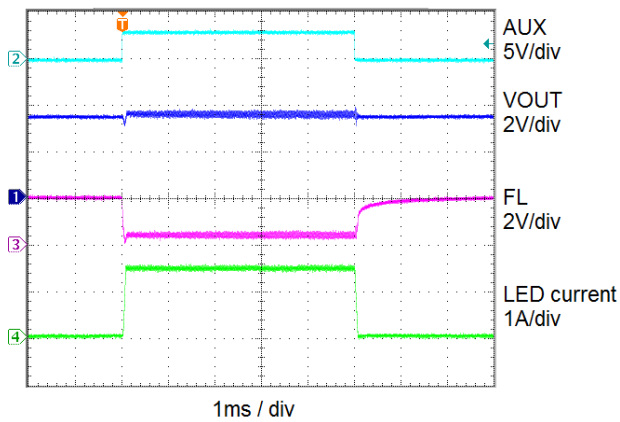

1.5A Flash with AUX (VIN = 4.2V)

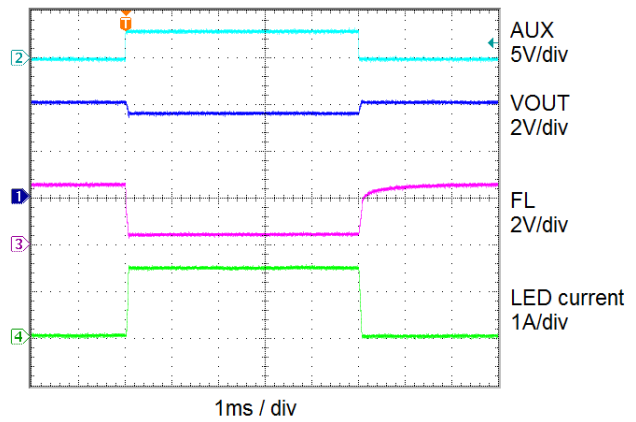

Typical Characteristics (continued)

1A Flash Turn On

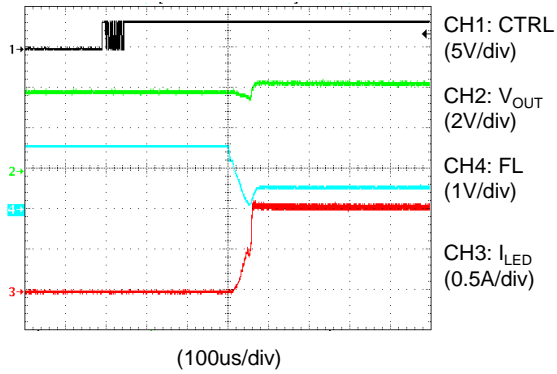

Flash Timeout Operation (1049ms setting)

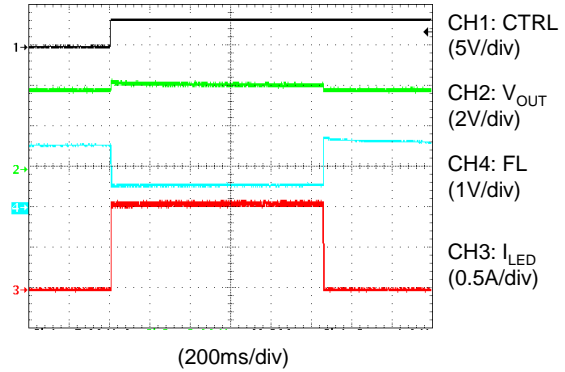

Movie-mode Turn On (106mA Setting)

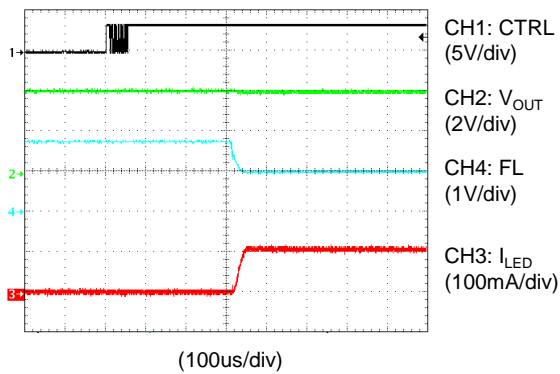

Movie-mode Turn Off (106mA Setting)

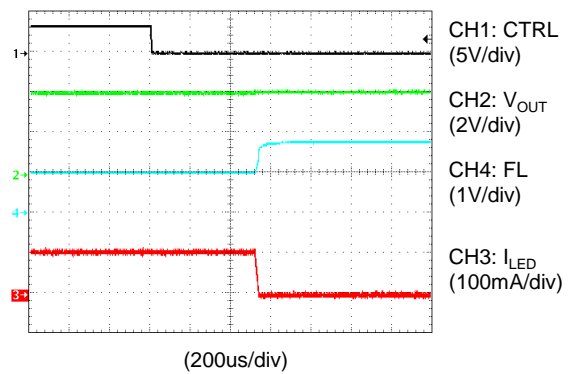

Movie-mode to Flash-mode (106mA to 1A)

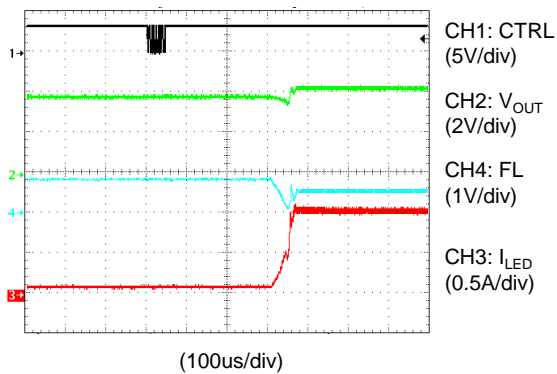

Flash-mode to Movie-mode (1A to 106mA)

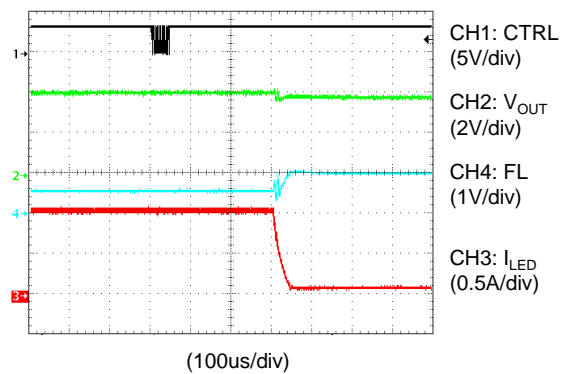

Functional Block Diagram

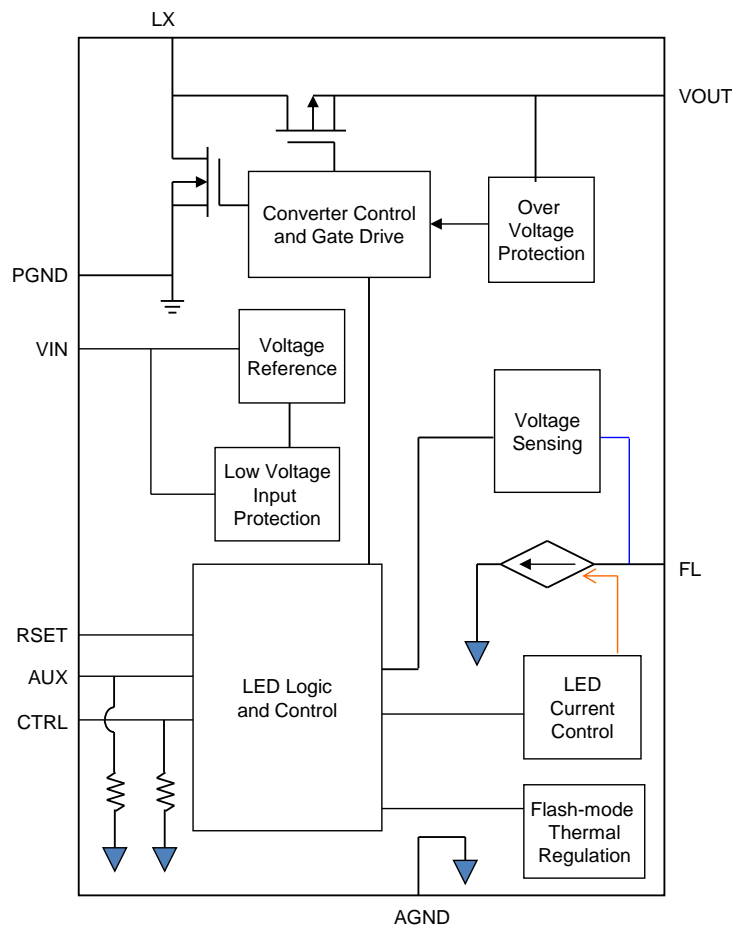

Functional Description

KTD2692 is a high switching frequency step-up (boost) flash LED driver in small package size. The voltage step-up is accomplished by a boost topology, using an inductor-based DC-DC switching converter, in which the inductor serves as an energy storage device. By integrating optimized power MOSFETs, KTD2692 internal switching frequency is 2.0MHz while still maintaining high power efficiency. Unlike a traditional DC-DC boost converter with a fixed output voltage, KTD2692 dynamically changes its output voltage depending on the flash LED forward voltage and current. The use of unique control schemes maintains accurate current regulation in the current sink while leaving the output voltage at a minimum, increasing the overall conversion efficiency. The internal step-up converter boosts the output voltage high enough to drive the LED, sinking up to 1.5A.

The control interface is designed for maximum design flexibility and compatibility with various types of system controls. The ExpressWire control into the CTRL pin can program the Low Voltage Protection (LVP), flash timeout duration, minimum current threshold for timer, and output current from 1/16 to 16/16 of the maximum respective flash or movie mode current.

The protocol consists of a device specific data byte, which includes 3 bits for register address and 5 bits for data. The interface includes the DS (Data Start) and EOD (End Of Data) for acknowledge condition of data bit.

The protocol starts from DS time for data input and ends with EOD time to recognize the end of data. Figure 1 shows the ExpressWire interface protocol.

The CTRL pin must be pulled high for at least t_{DS} (min. 10 μ s) before the data start with the falling edge. If the CTRL pin is already at high level, the t_{DS} (min. 10 μ s) is not necessary. The data byte is ended with a EOD (End OF Data) condition for at least t_{EOD_L} (min. 2 μ s) and t_{EOD_H} (min. 350 μ s).

The Low Bit(0) and High Bit(1) is based on a time detection algorithm between t_{LOW} and t_{HIGH} .

The t_{L_LB} is low time of the Low Bit(0) and the t_{H_LB} is high time of the Low Bit(0).

The t_{L_HB} is low time of the High Bit(1) and the t_{H_HB} is high time of the High Bit(1).

It can be simplified to :

Low Bit(0) : $t_{H_LB} < t_{L_LB}$, but with t_{L_LB} at least 2x t_{H_LB} (see Figure 5)

High Bit(1) : $t_{H_HB} > t_{L_HB}$, but with t_{H_HB} at least 2x t_{L_HB} (see Figure 5)

Register Description

The programming register address and data are illustrated in Table 1.

- Register (101) selects Flash/Movie modes, by default Flash/Movie modes are off.
- Register (100) programs the Flash mode current in 16 steps, the maximum Flash mode current is set by external RSET resistor.
- Register (011) programs the Movie mode current in 16 steps, the maximum Movie mode current is set as 1/3 of the maximum Flash mode current.
- Register (010) programs the minimum current for Timer protection. Only after the LED current reaches this minimum threshold, the Timer starts to count.
- Register (001) programs the flash timeout setting. Once the LED current goes above the minimum value (set by Register 010) for more than this time, the LED current will be turned off and Register (101) will be reset to the default value to keep Flash/Movie mode off. User needs to program Register (101) again to restart.
- Register (000) programs the LVP threshold. When the LED current is on and VIN voltage goes below this threshold for more than 32 μ s, the LED current will be turned off and Register (101) will be reset to the default value to keep Flash/Movie mode off. User needs to program Register (101) again to restart. If VIN voltage is already below LVP threshold when Flash/Movie mode is enabled, the IC will not start and Register (101) will be reset to the default value to keep Flash/Movie mode off.

When the AUX pin is pulled high while the CTRL is high, the LED current ramps-up to the flash mode current level which is programmed by RSET resistor and the Register (100)'s setting. That means AUX has a higher priority over CTRL when CTRL is high. The driver goes into shutdown mode once the CTRL input is kept low for t_{RESET} time (see Figure 4). The CTRL and AUX control logic inputs and output are described in Table 1/2/3/4/5.

Table 1. Register Map Table

Byte Value	Address/Data Byte							Register Name	Description	
	A2	A1	A0	D4	D3	D2	D1			D0
0	0	0	0	X	X	0	0	0	LVP Setting (Low Voltage Protection)	Disable LVP Function
1				X	X	0	0	1		3.2V
2				X	X	0	1	0		3.3V
3				X	X	0	1	1		3.4V
4				X	X	1	0	0		3.5V (Default)
5				X	X	1	0	1		3.6V
6				X	X	1	1	0		3.7V
7				X	X	1	1	1		3.8V
8	0	0	1	X	X	0	0	0	Flash Timeout Setting	Disable Timer Function
9				X	X	0	0	1		262msec
10				X	X	0	1	0		524msec
11				X	X	0	1	1		786msec
12				X	X	1	0	0		1049msec (Default)
13				X	X	1	0	1		1311msec
14				X	X	1	1	0		1573msec
15				X	X	1	1	1		1835msec
16	0	1	0	X	X	0	0	0	Min. Current Setting for Timer Operating	typ. 90mA
17				X	X	0	0	1		typ. 120mA
18				X	X	0	1	0		typ. 150mA
19				X	X	0	1	1		typ. 180mA
20				X	X	1	0	0		typ. 210mA
21				X	X	1	0	1		typ. 240mA (Default)
22				X	X	1	1	0		typ. 270mA
23				X	X	1	1	1		typ. 300mA
24	0	1	1	X	0	0	0	0	Movie Current Setting	1/16 x (Iflash_max ÷ 3)
25				X	0	0	0	1		2/16x (Iflash_max ÷ 3)
26				X	0	0	1	0		3/16 x (Iflash_max ÷ 3)
27				X	0	0	1	1		4/16 x (Iflash_max ÷ 3)
28				X	0	1	0	0		5/16 x (Iflash_max ÷ 3) (Default)
29				X	0	1	0	1		6/16 x (Iflash_max ÷ 3)
30				X	0	1	1	0		7/16 x (Iflash_max ÷ 3)
31				X	0	1	1	1		8/16 x (Iflash_max ÷ 3)
32				X	1	0	0	0		9/16 x (Iflash_max ÷ 3)
33				X	1	0	0	1		10/16 x (Iflash_max ÷ 3)
34				X	1	0	1	0		11/16 x (Iflash_max ÷ 3)
35				X	1	0	1	1		12/16 x (Iflash_max ÷ 3)
36				X	1	1	0	0		13/16 x (Iflash_max ÷ 3)
37				X	1	1	0	1		14/16 x (Iflash_max ÷ 3)
38				X	1	1	1	0		15/16 x (Iflash_max ÷ 3)
39				X	1	1	1	1		16/16x (Iflash_max ÷ 3)
40	1	0	0	X	0	0	0	0	Flash Current Setting	1/16 x Iflash_max
41				X	0	0	0	1		2/16 x Iflash_max
42				X	0	0	1	0		3/16 x Iflash_max
43				X	0	0	1	1		4/16 x Iflash_max
44				X	0	1	0	0		5/16 x Iflash_max
45				X	0	1	0	1		6/16 x Iflash_max
46				X	0	1	1	0		7/16 x Iflash_max
47				X	0	1	1	1		8/16 x Iflash_max
48				X	1	0	0	0		9/16 x Iflash_max
49				X	1	0	0	1		10/16 x Iflash_max
50				X	1	0	1	0		11/16 x Iflash_max
51				X	1	0	1	1		12/16 x Iflash_max
52				X	1	1	0	0		13/16 x Iflash_max
53				X	1	1	0	1		14/16 x Iflash_max
54				X	1	1	1	0		15/16 x Iflash_max
55				X	1	1	1	1		16/16 x Iflash_max (Default)
56				X	X	X	0	0		Disables Movie/Flash Mode (Default)
57	1	0	1	X	X	X	0	1	Movie/Flash Mode Control	Enable Movie Mode
58	X	X	X	X	1	0				Enable Flash Mode

LED Current Programming

The LED current can be programmed up to 1.5A. The maximum current is set by the RSET resistor. For the desired flash-mode current, the resistor value can be calculated using the following equation:

$$I_{FLASH_MAX} = 15000 / R_{RSET}$$

Once the maximum flash current is set, the flash current can be programmed through ExpressWire control on the CTRL pin as described here.

ExpressWire Interface Protocol

Output control and programmability is achieved by using the CTRL pin. Refer to the figures below for further explanation of the interface protocol.

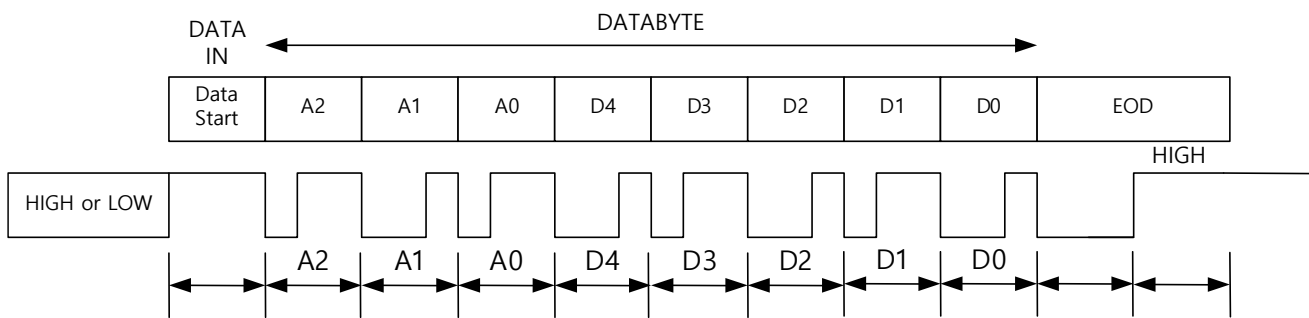

Figure 1. ExpressWire Interface Protocol Overview

Table 2. CTRL Register Table

IC Pin	Byte	Bit Number	Name	Direction	Description
CTRL	Data Byte	7 (MSB)	A2	INPUT	Reg Address BIT 2
		6	A1		Reg Address BIT 1
		5	A0		Reg Address BIT 0
		4	D4		DATA BIT 4
		3	D3		DATA BIT 3
		2	D2		DATA BIT 2
		1	D1		DATA BIT 1
		0 (LSB)	D0		DATA BIT 0

Example of sequence of commands for turning on the flash LED:

Command	Register byte in hexadecimal
LVP setting at 3.3V	01
Flash current setting 15/16 max	6E
Enable flash mode	A2
Wait 100ms (flash duration)	-
Disable flash mode	A0

Table 3. CTRL Address Summary Table

IC Pin	Address BIT			Description
	A2	A1	A0	
CTRL	0	0	0	LVP Setting Address
	0	0	1	Flash Timeout Setting Address
	0	1	0	Min. Current for Timer Operating Setting Address
	0	1	1	Movie Mode Current Setting Address
	1	0	0	Flash Mode Current Setting Address
	1	0	1	Movie & Flash Mode Control Address

Table 4. CTRL Reset Control Table

IC Pin	Control	Description
CTRL	Low (> 700usec)	- Reset and Clear Register - Automatically set to default values

Table 5. CTRL Flash and Movie Mode ON/OFF Control Table

IC Pin	Data BIT		Control	Description
	D1	D0		
CTRL	0	0	Disable	LED OFF
	0	1	MOVIE	Enable Movie Mode (ON)
	1	0	FLASH	Enable Flash Mode (ON)

Table 6. AUX Control Table

IC Pin	Control	Description
AUX	Rising Edge Enable	Set to Programmed Flash Mode

ExpressWire Interface Bit Coding

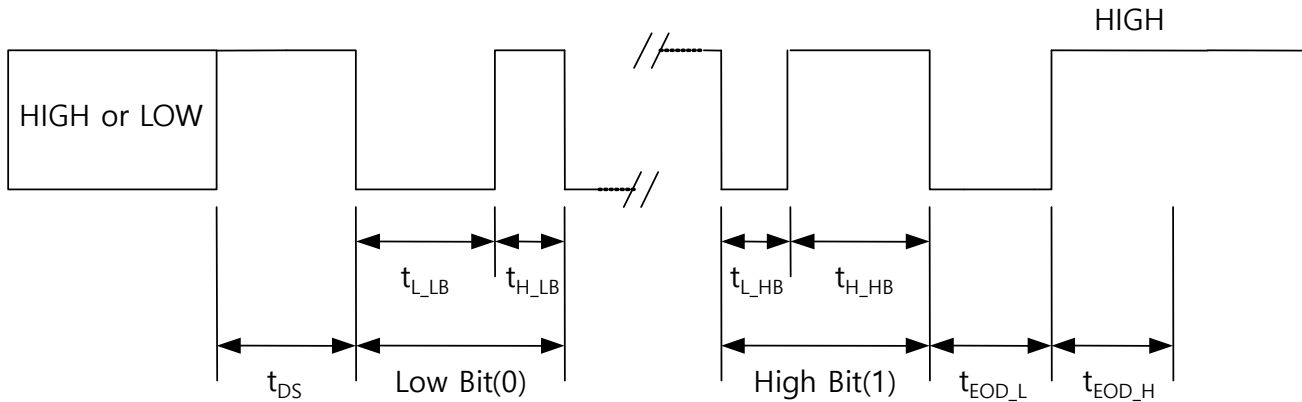

Figure 2. ExpressWire Interface – Bit Coding

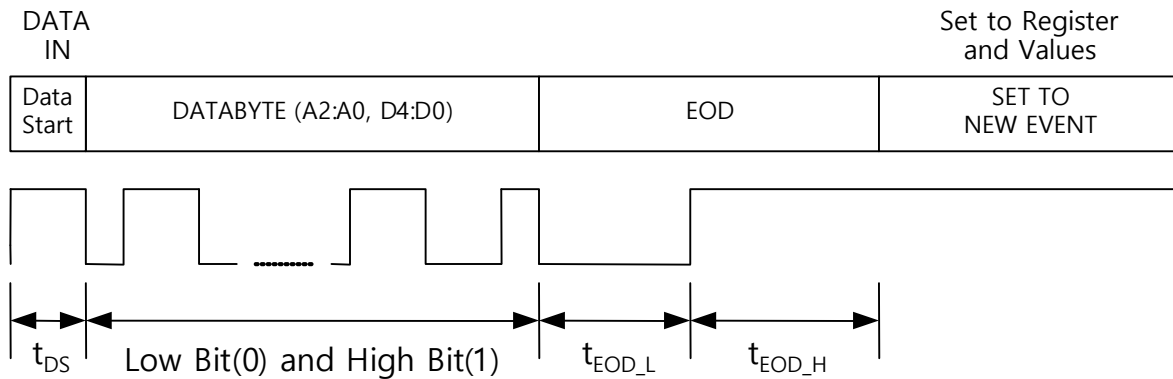

Figure 3. ExpressWire Interface – Write to Register Overview

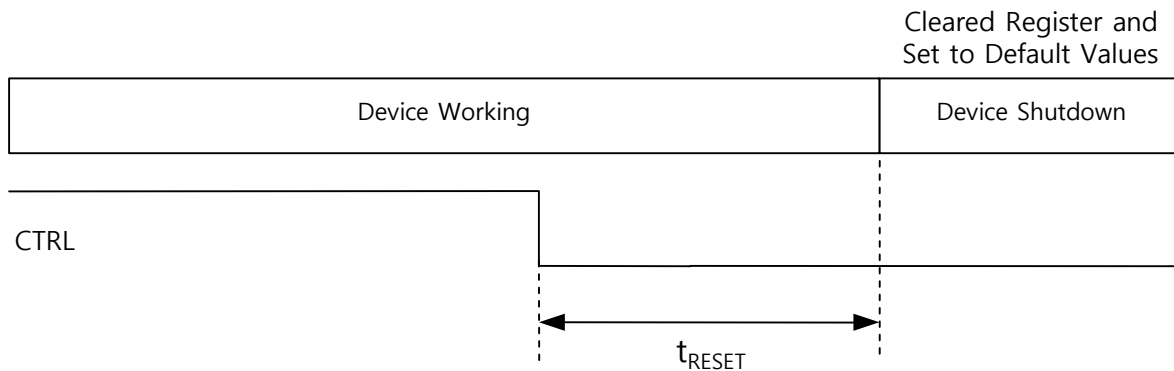
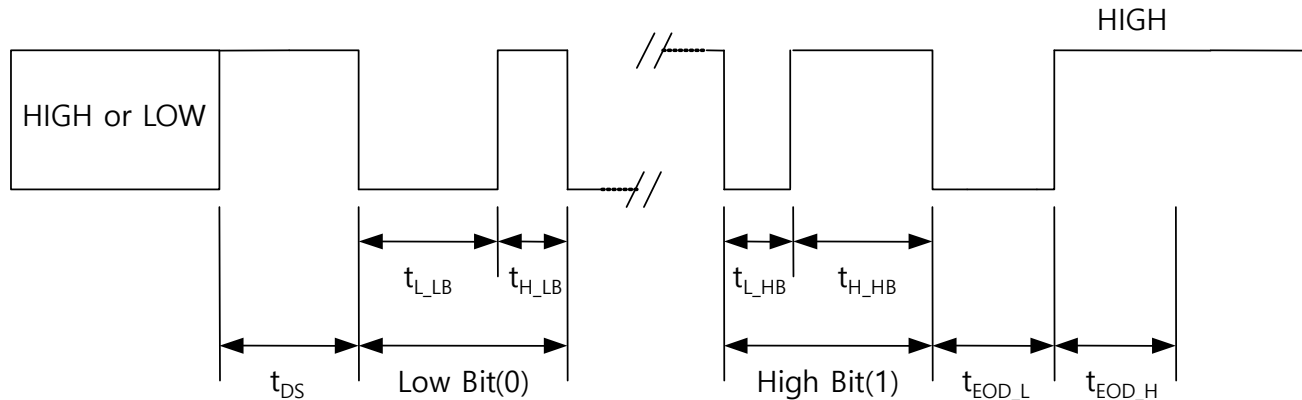

Figure 4. ExpressWire Interface – Set to Reset and Shutdown

ExpressWire Interface – Programming Bit Coding Time

Figure 5. ExpressWire Interface – Bit Coding Time

1. Minimum Data Start Time (t_{DS}) : min. 10 μ s
2. t_{H_LB} : min. 2.0 μ s ~ max. 64 μ s
3. t_{L_LB} : min. 4.0 μ s ~ max. 128 μ s ($t_{L_LB} = t_{H_LB} \times 2$)
4. t_{H_HB} : min. 4.0 μ s ~ max. 128 μ s ($t_{H_HB} = t_{L_HB} \times 2$)
5. t_{L_HB} : min. 2.0 μ s ~ max. 64 μ s
6. Low End Of Data (t_{EOD_L}) : min. 2.0 μ s ~ max. 64 μ s
7. High End Of Data (t_{EOD_H}) : > 350 μ s
8. Minimum Reset Time, t_{RESET} : min. 700 μ s

Thermal Regulation

Automatic thermal regulation control is active when KTD2692's output is turned on. If the output is operating at a high current value, the temperature of the IC can increase quickly. Once the IC's temperature goes above 120°C, the average sink current will be automatically decreased according to the thermal regulation control loop. This can prevent the IC from triggering thermal shutdown and causing the LED to flicker. Depending on the thermal layout of the PCB and the flash mode current setting, KTD2692 sink current can be lower than the programmed value due to the thermal regulation protection feature.

Low Voltage Input Protection

Using the LVP function, KTD2692 monitors the input voltage through an internal protection circuit. When the voltage applied to VIN pin is below the threshold set by Register (000), KTD2692 will disable the output current in both Flash mode and Movie mode and reset Register (101) to its default value. The setting can be programmed to the desired value for each particular system, depending on factors such as battery ESR and dynamic current requirements of other loads in the system. Also it can be disabled if the system doesn't need this protection. Once LVP is triggered, user needs to program Register (101) again to restart.

LED Short Protection

When Flash or Movie mode is enabled, there is an extra 2mA LED sensing current through the current sink. It is used to detect whether the LED is shorted by generating a voltage drop through the LED. The IC internally compares the voltage difference between VOUT and the sink node (FL). If this difference is below a preset threshold of 1.7V, the IC will treat the LED as shorted and disable its Flash/Movie mode current at the output. However, the 2mA sensing current will be kept to generate the LED's voltage drop. Depending on the Vf specifications of the LED used, this sensing current can guarantee that a properly functioning LED will not mistakenly be treated as a shorted LED. If the short circuit is removed during operation, the LED current will automatically recover to the programmed current setting.

LED Open Protection

In case of LED open, the VOUT will reach OVP (approximately 5.3V), then KTD2692 will automatically detect the fault and disable the driver by resetting Register (101) to its default value to turn off Flash/Movie mode. User needs to program Register (101) again to restart.

Inductor Selection

The KTD2692 is designed to use a 1.0μH to 2.2μH inductor. To prevent core saturation, ensure that the inductor-saturation current rating exceeds the peak inductor current for the application. The worst-case peak inductor current can be calculated with the following formula:

$$I_{Peak(L)} = \frac{V_{O(MAX)} \times I_{LED(MAX)}}{\eta \times V_{IN(MIN)}} + \frac{V_{IN(MIN)} \times t_{ON(MAX)}}{2 \times L}$$

where η is the estimated efficiency.

For example, for a 1.0A LED current, the peak inductor current for a 1.0μH inductor could be as high as (estimated 50% as the maximum duty ratio at the worst case efficiency of 80%, minimum input voltage of 3.5V, 4.0V of output voltage, and maximum load current conditions):

$$I_{Peak(L)} = \frac{4.0V \times 1.0A}{0.8 \times 3.5V} + \frac{3.5V \times 0.25\mu s}{2 \times 1\mu H} = 1.87A$$

If the inductor value is smaller, the inductor peak current will increase. To maintain stable operation for the boost converter, the inductor peak current must be less than both the KTD2692 current limit threshold and the inductor saturation current rating. Manufacturer's specifications of inductors list both the inductor DC current rating, which is a thermal limitation, and peak inductor current rating, which is determined by the saturation characteristics. Measurements at full load and high ambient temperature should be performed to ensure that the inductor does not saturate or overheat due to its parasitic resistance. Bench measurements are recommended to confirm actual inductor peak current I_{PEAK} and to ensure that the inductor does not saturate at maximum LED current and minimum input supply voltage.

Capacitor Selection

For good input voltage filtering, X5R or X7R low ESR ceramic capacitors are required.

A 4.7μF minimum input capacitor is recommended for high current flash LEDs to improve transient behavior of the regulator and EMI behavior of the total power supply circuit. The input capacitor should be placed as close as possible to the VIN pin and the PGND pin of the KTD2692.

The output capacitance value depends on the maximum LED current. A 4.7μF to 10μF ceramic capacitor is fine for most applications. The output capacitor should be connected between the VOUT pin and PGND pin.

PC Board Layout

Due to the fast switching transitions and high-current paths, careful PC board layout is required. Connect AGND pin directly to the exposed paddle underneath the IC; connect the exposed paddle to the PCB ground plane. The output bypass capacitor should be placed as close to the IC as possible. Minimize trace lengths between the IC and the inductor, the input capacitor, and the output capacitor; keep these traces short, direct, and wide. The ground connections of C_{IN} and C_{OUT} should be as close together as possible and connected to PGND. The current setting resistor R_{SET} should be Kelvin connected directly to the AGND pin.

A recommended PCB layout is shown in Figure 6. In order to dissipate the package heat, the package center pad (MC) must be connected to a large copper area on the bottom side through multiple via.

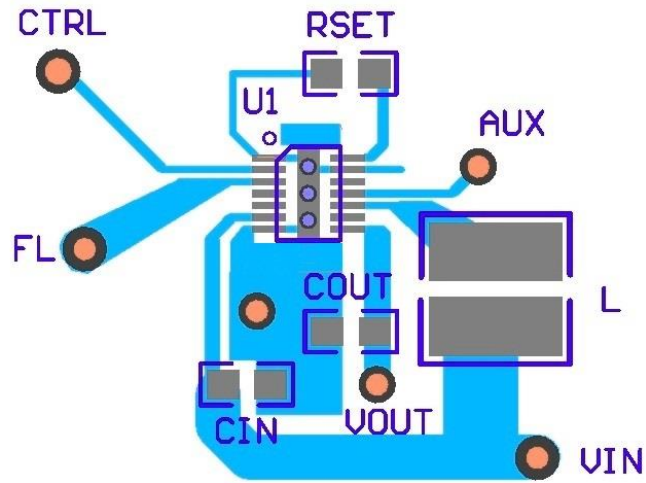
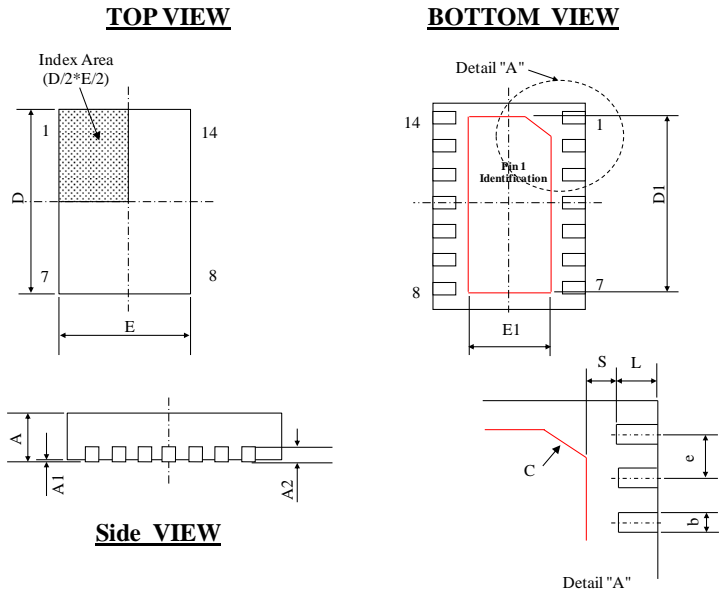

Figure 6. Recommended PCB Layout

Packaging Information

TDFN23-14



Dimension	mm		
	Min.	Typ.	Max.
A	0.70	0.75	0.85
A1	0.00	0.05	0.10
A2	0.18	0.23	0.28
b	0.14	0.21	0.28
c	0.35 REF		
D	2.90	3.00	3.10
D1	2.35	2.50	2.65
E	1.90	2.00	2.10
E1	0.70	0.80	0.90
e	0.40BSC		
L	0.30	0.35	0.40
S	0.125 MIN		

TDFN23-14 Recommended PCB Landing Pattern – Top View

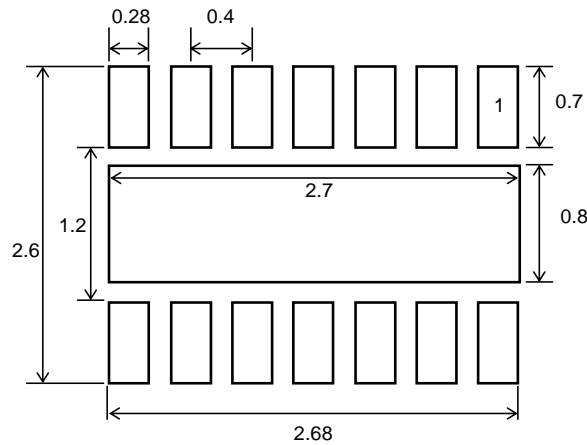

*Dimensions are in millimeters

Kinetic Technologies cannot assume responsibility for use of any circuitry other than circuitry entirely embodied in a Kinetic Technologies product. No intellectual property or circuit patent licenses are implied. Kinetic Technologies reserves the right to change the circuitry and specifications without notice at any time.