

4.7V to 18V Input, 5A Synchronous Buck Regulators with AOT Control

Features

- Wide V_{IN} Range: 4.7V to 18V
- Maximum Continuous Output Current: 5A
- $V_{OUT} = 1.8V$
- Different fixed options are available for predefined output voltage by the factory.
- Integrated High / Low-Side FETs (65m Ω / 35m Ω)
- Advanced Adaptive On-Time Control
- Fast Transient Response
- Open Drain Power Good Indicator
- $\pm 0.5\%$ Feedback Voltage Reference
- Zero Shutdown Supply Current
- 50 μA Non-Switching Operating Quiescent Current
- 80 μA No Load Operating Quiescent Current
- High Efficiency in Light Load and Heavy Load.
- Factory 300kHz, 500kHz, 800kHz, 1MHz Switching Frequency Options Available Upon Request
- Internal Soft-Start
- Factory Forced CCM (FCCM) or automatic CCM/PFM (Auto-Skip) Options
- Active discharge Mode option
- Ultrasonic Mode option to Eliminate Audio Noise
- Built-in Cycle-by-Cycle Current Limit, Short Circuit Protection, Input UVLO, Output Under-Voltage Protection, Output Over-Voltage Protection, and Thermal Shutdown Protection
- 11-Pin UQFN (2.2mm x 2.5mm) Package

Brief Description

KTB8372 is 5A, 18V synchronous buck regulators with integrated high-side and low-side power FETs. The device operates over a wide input voltage range to support a variety of applications with input voltage from regulated 5V and 12V power rails and multicell batteries. The fixed options for output voltage can be predefined and trimmed by the factory.

KTB8372 employs Kinetic's proprietary advanced adaptive on-time (AOT) control for fast transient response and high output voltage accuracy. This control technique eliminates external loop compensation network and allows the use of ceramic output capacitors without ripple-generating circuitry. These features enable a very small total solution size and make KTB8372 easy to use.

The device features an internal soft-start function to limit inrush current during start-up. The device has comprehensive built-in protection features including input voltage UVLO, high-side cycle-by-cycle peak current limit, low-side valley current limit, reverse current protection, short-circuit protection, output over-voltage protection, and thermal shutdown.

KTB8372 are available in RoHS and Green compliant 11-Pin UQFN (2.2mm x 2.5mm) package.

Applications

- CPU, GPU, AP, DSP, FPGA, VIO, VSYS
- HDD, LPDDR3, LPDDR4 Memory Power
- Tablets, Netbooks, Ultra-Books, Mobile Internet Devices, IoT, and Server.
- DSC, Drones, Gaming Consoles, TV Set Box

Typical Application Schematic

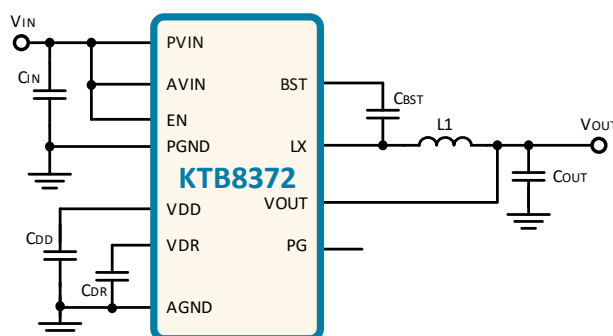

Pinout Diagram

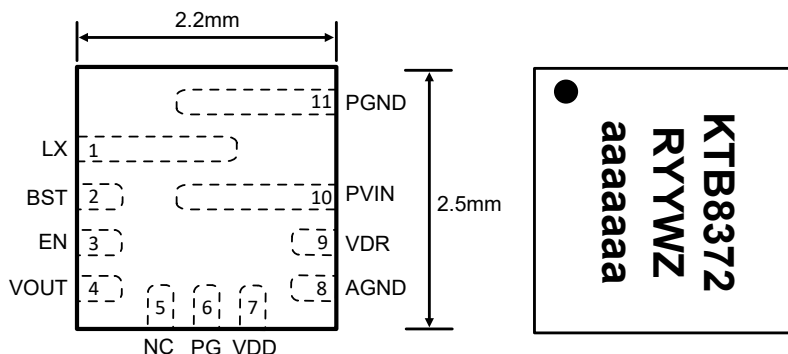

Top Mark

UQFN-11 Package

(2.20mm x 2.50mm x 0.55mm)

RY = Device ID Code, YW = Date Code, Z = Serial Number

aaaaaaa = Assembly Lot Tracking Number

Pin Descriptions

Pin Name	Function	
1	LX	Inductor connection for buck regulator.
2	BST	Boost capacitor for charge pump gate driver.
3	EN	Chip enable logic input.
4	VOUT	Output voltage sense input.
5	NC	NC Pin, must be tied to AGND.
6	PG	Open-drain Power Good Indicator Output. Connect a pull-up resistor between PG pin and VDD pin, a resistor ranges from 10kΩ to 100kΩ is recommended. This pin is pulled to ground when the output voltage is outside of its specified threshold. If not used, tie to AGND or PGND.
7	VDD	Analog circuit bias voltage.
8	AGND	Analog ground for analog circuit.
9	VDR	Power stage driver voltage.
10	PVIN	Input Voltage Power and Sense Pins for buck regulator. Connect to a power rail ranges from 4.7V to 18V.
11	PGND	Power ground for buck regulator.

Ordering Information

Part Number ¹	Marking ²	Default Settings ³					Package
		V _{out}	F _{sw}	FCCM or Auto-Skip Mode	Active Discharged	Ultrasonic Mode	
KTB8372CEUFA-5C-TA	RYYWZ	1.8V	500kHz	Auto-Skip	Disabled	Disabled	UQFN-11

1. For part numbers in italics or alternative default combinations, please contact your local sales representative.

2. RY = Device ID Code, YW = Date Code, Z = Serial Number. aaaaaaa = Assembly Lot Tracking Number.

3. Contact a Kinetic Technologies representative regarding versions with other default settings.

Absolute Maximum Ratings ⁴

(T_A = 25°C unless otherwise noted)

Description		Value	Units
PVIN to PGND		-0.3 to 19	V
PGND to AGND		-0.3 to 0.3	V
LX to PGND		-0.3 to (PVIN +0.3)	V
BST to LX		-0.3 to 5.5	V
VOUT, VDD, VDR, EN, and PG to AGND		-0.3 to 5.5	V
LX	Continuous Current	7	A _{RMS}
	Peak Current (2.5ms maximum)	10	A _{PEAK}
Operating Junction Temperature Range		-40 to 150	°C
Storage Temperature Range		-55 to 150	°C
Maximum Soldering Temperature (at leads, 10 sec)		260	°C

ESD and Surge Ratings⁵

Symbol	Description	Value	Units
V (ESD) Electrostatic Discharge	Human body model (HBM), per ANSI/ESDA/JEDEC JS-001, all pins	±2000	V
	Charged device model (CDM), per JEDEC specification JESD22C101, all pins	±500	

Thermal Capabilities⁶

Symbol	Description	Value	Units
θ _{JA}	Thermal Resistance – Junction to Ambient	59.6	°C/W
P _D	Maximum Power Dissipation at T _A = 25°C	1.67	W
ΔPD/ΔT	Derating Factor Above T _A = 25°C	-16.7	mW/°C

4. Stresses above those listed in Absolute Maximum Ratings may cause permanent damage to the device. Functional operation at conditions other than the operating conditions specified is not implied. Only one Absolute Maximum rating should be applied at any one time.
5. ESD and Surge Ratings conform to JEDEC and IEC industry standards. Some pins may actually have higher performance. Surge ratings apply with chip enabled, disabled, or unpowered, unless otherwise noted.
6. Junction to Ambient thermal resistance is highly dependent on PCB layout. Values are based on thermal properties of the device when soldered to an EV board.

Electrical Characteristics⁷

Unless otherwise noted, *Typ* values are specified at $T_J = +25^\circ\text{C}$ with $V_{IN} = 12\text{V}$. The *Min* and *Max* specs are applied over the full operation temperature range of $T_J = -40^\circ\text{C}$ to $+125^\circ\text{C}$ and $V_{IN} = 4.7\text{V}$ to 18V .

Symbol	Description	Conditions	Min	Typ	Max	Units
Supply Specifications						
PV_{IN}	Input Supply Operating Range		4.7		18	V
V_{UVLO}	Under-Voltage Lockout Threshold	V_{IN} rising	3.35	4.25	4.7	V
		Hysteresis		500		mV
I_{IN}	V_{IN} Supply Current	EN = High, $V_{IN} = 12\text{V}$, Non-Switching		50		μA
		EN = High, $V_{IN} = 12\text{V}$, Auto-Skip		80		μA
		EN = High, $V_{IN} = 12\text{V}$, Forced-PWM		10		mA
I_{SHDN}	Shutdown Supply Current	EN = Low, $T_A = 25^\circ\text{C}$		0.01	1	μA
Logic Pin Specifications (EN, PG)						
V_{IH}	Input Logic High (EN)		3.8			V
V_{IL}	Input Logic Low (EN)				0.4	V
I_{L_LK}	Input Logic Leakage (EN)	$T_A = 25^\circ\text{C}$, $V_{EN} = 5\text{V}$		0.01	1	μA
V_{OL}	Output Logic Low (PG)	$I_{O_SINK} = 100\mu\text{A}$			0.4	V
I_{O_LK}	Output Logic Leakage (PG)	$T_A = 25^\circ\text{C}$, $V_O = 5.5\text{V}$		1.5	3.8	μA
Thermal Shutdown Specifications						
T_{J_SHDN}	IC Junction Thermal Shutdown	T_J rising		150		$^\circ\text{C}$
		Hysteresis		20		$^\circ\text{C}$
Buck Regulator Specifications						
V_{OUT}	Output Voltage Setting Range	Factory Programmable Options	0.64		5.5	V
		Output Voltage Step		40		mV
V_{OUT_acc}	Output Voltage DC Accuracy	$T_A = 25^\circ\text{C}$, FCCM	-0.7		0.7	%
I_{OUT_max}	Maximum Continuous Output Current		5			A
I_{peak}	High-Side Switch Peak-Current Limiting Threshold		6.4	8	9.6	A
I_{valley}	Low-Side Switch Valley-Current Limiting Threshold		6	7.5	9	A
I_{rev}	Low-Side Reverse Current Limiting Threshold	FCCM Mode		-3		A
I_{zcd}	Zero-Crossing-Detection Threshold	Auto-Skip Mode		0		mA
R_{dson_h}	High-Side Switch On-Resistance			60	75	m Ω
R_{dson_l}	Low-Side Switch On-Resistance			30	40	m Ω
R_{LX_DIS}	LX Active Discharge Resistance	For Active discharge mode enabled option		200		Ω
K_{AOT}	Adaptive-On-Time Constant	$t_{ON} = K_{AOT} \times (V_{OUT}/V_{IN})$, $F_{SW} = 500\text{kHz}$, $V_{OUT} = 5\text{V}$		2100		ns
F_{SW}^8	Switching Frequency Factory Trim Options	$F_{SW} = 300\text{kHz}$		300		kHz
		$F_{SW} = 500\text{kHz}$		500		
		$F_{SW} = 800\text{kHz}$		800		
		$F_{SW} = 1000\text{kHz}$		1000		
t_{SS_DELAY}	V_{OUT} Soft-Start Delay	EN = Low to High		2		ms
V_{OUT_RR}	V_{OUT} Soft-Start Ramp Rate	$V_{OUT} = 5\text{V}$		8		mV/ μs
		$V_{OUT} = 3.3\text{V}$		4		
		$V_{OUT} = 1.8\text{V}$		3		
V_{OUT_PG}	Output Voltage Power-Good Threshold	Percentage of nominal V_{OUT}	85		115	%

⁷ Device is guaranteed to meet performance specifications over the -40°C to $+85^\circ\text{C}$ operating temperature range by design, characterization, and correlation with statistical process controls.

⁸ Switching frequency is factory trimmed options, please refer to ordering information to select relevant part. Switching frequency is factory trimmed options, please refer to ordering information to select relevant part.

Typical Characteristics

Unless otherwise noted, $V_{IN} = 12V$, $F_{sw} = 500kHz$, and $T_A = 25^\circ C$.

Efficiency vs Output Current
($L1 = 2.2\mu H$, $F_{sw} = 500kHz$)

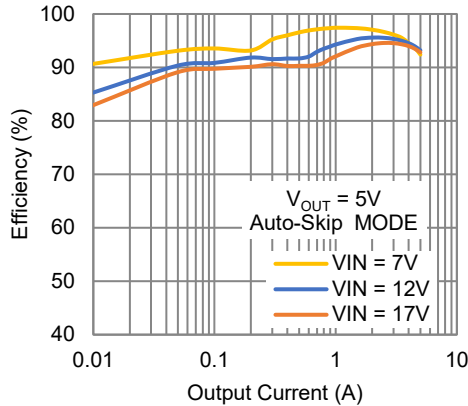

Efficiency vs Output Current
($L1 = 2.2\mu H$, $F_{sw} = 500kHz$)

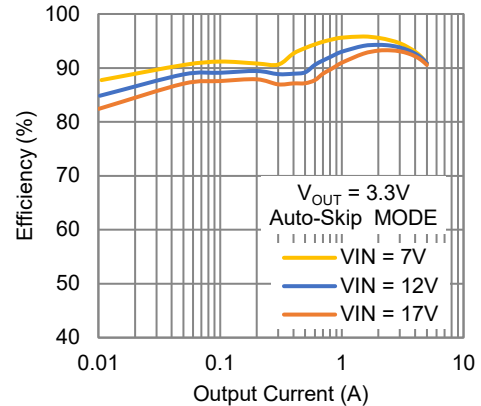

Efficiency vs Output Current
($L1 = 2.2\mu H$, $F_{sw} = 500kHz$)

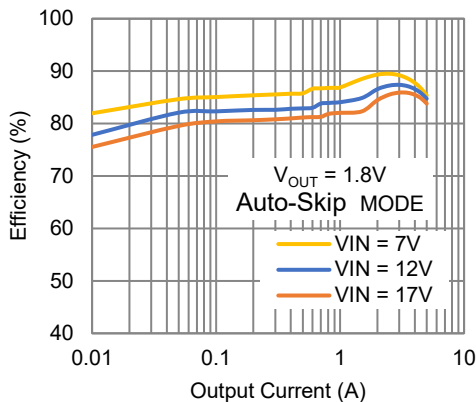

No Load Input Supply Current vs VIN

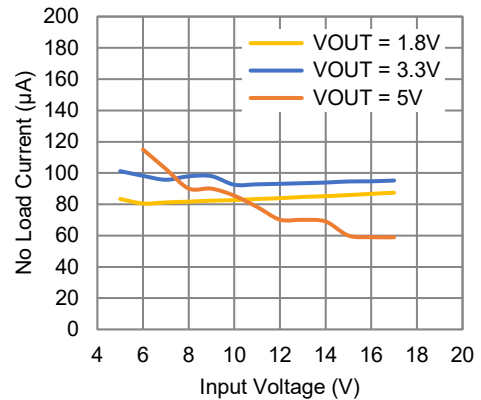

Switching Frequency vs. Output Current

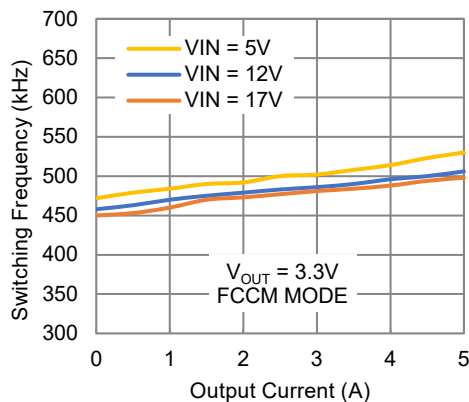

Line Regulation ($V_{OUT} = 5V$, Auto-Skip Mode)

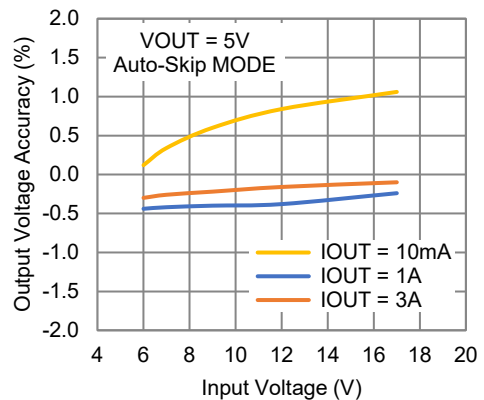

Typical Characteristics (continued)

Unless otherwise noted, $V_{IN} = 12V$, $F_{SW} = 500kHz$, and $T_A = 25^\circ C$.

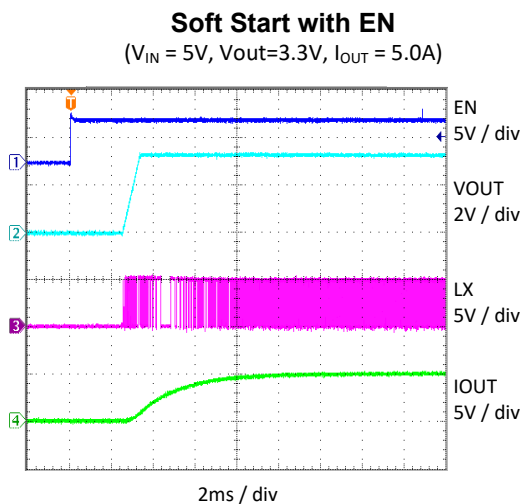
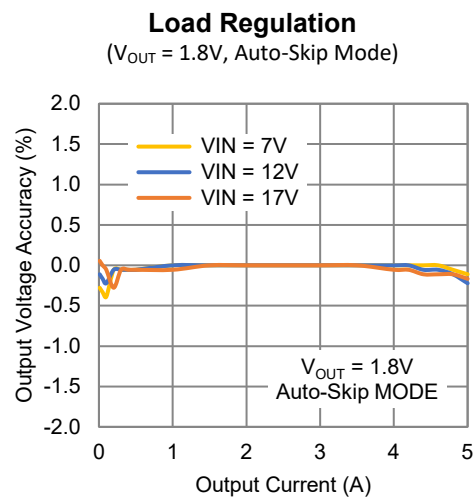
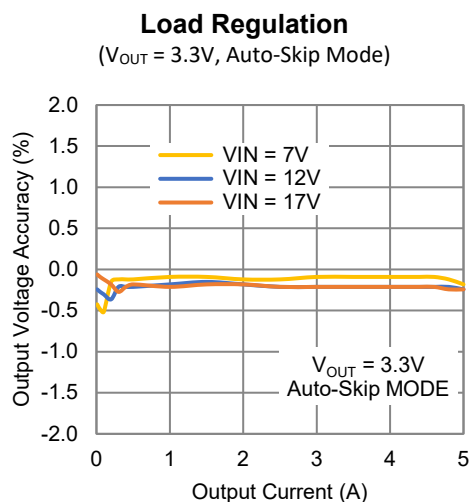
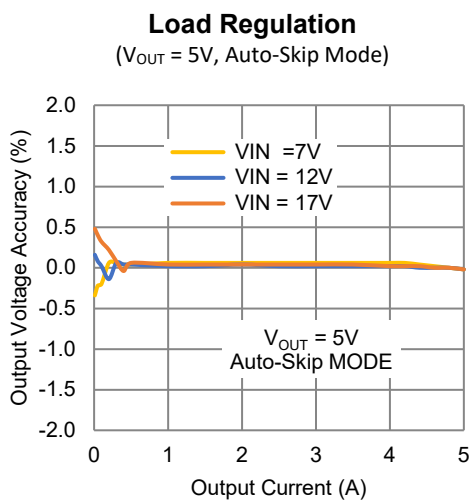
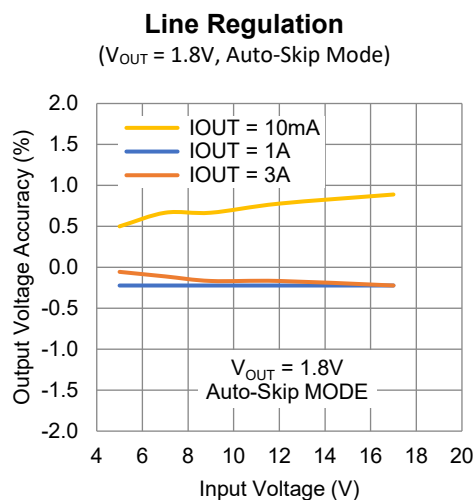
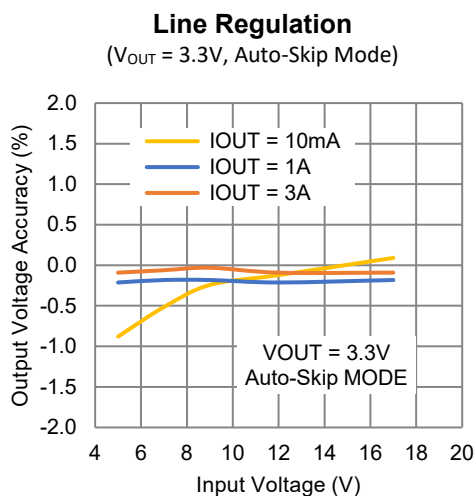

Typical Characteristics (continued)

Unless otherwise noted, $V_{IN} = 12V$, $F_{SW} = 500kHz$, and $T_A = 25^\circ C$.

Shutdown with EN

($V_{IN} = 5V$, $V_{OUT} = 3.3V$, $I_{OUT} = 5.0A$)

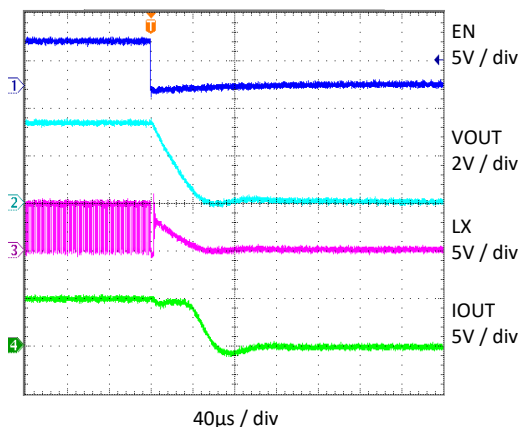

Output Active Discharge

($V_{IN} = 12V$, $V_{OUT} = 3.3V$, $I_{OUT} = 0mA$)

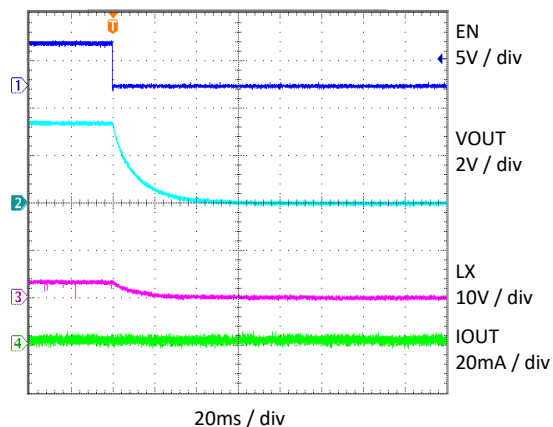

Output Voltage Ripple

($V_{IN} = 12V$, $V_{OUT} = 3.3V$, $I_{OUT} = 5A$)

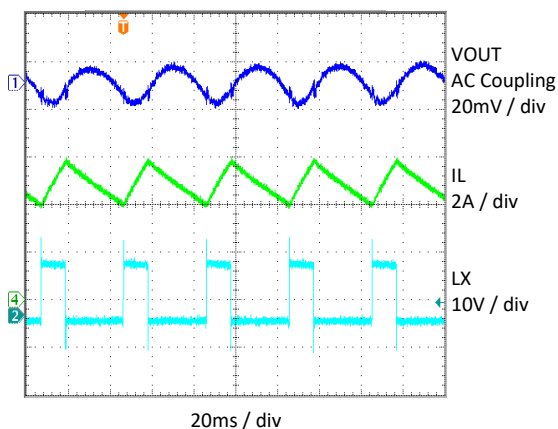

Load Transient

$V_{IN} = 12V$, $V_{OUT} = 3.3V$, (0.1A-2.5A, Auto-Skip Mode)

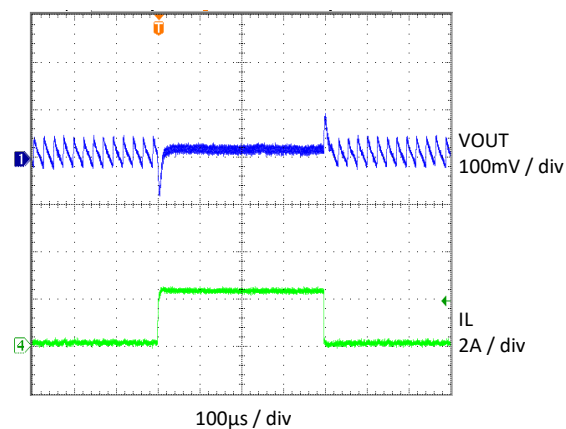

Load Transient

$V_{IN} = 12V$, $V_{OUT} = 3.3V$, (1.5A-4.5A, Auto-Skip Mode)

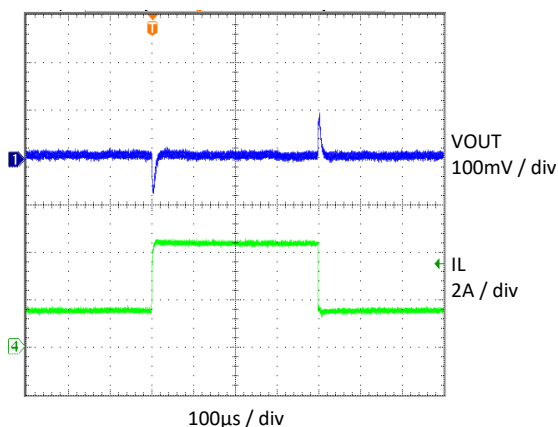

Load Transient

$V_{IN} = 12V$, $V_{OUT} = 3.3V$, (0A-4.5A, Auto-Skip Mode)

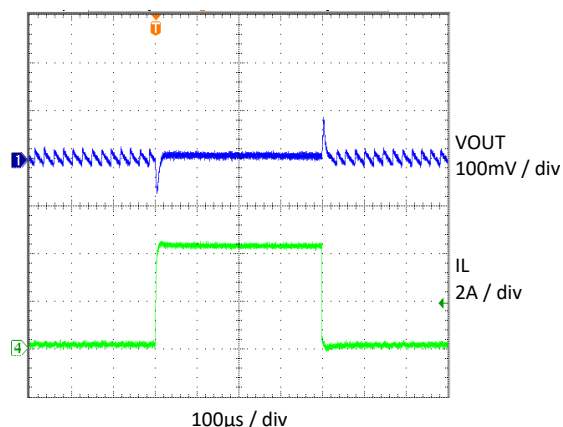

Typical Characteristics (continued)

Unless otherwise noted, $V_{IN} = 12V$, $F_{SW} = 500kHz$, and $T_A = 25^{\circ}C$.

Output Short Protection Entry

$V_{IN} = 12V$, $V_{OUT} = 3.3V$, (Hiccup Mode Entry)

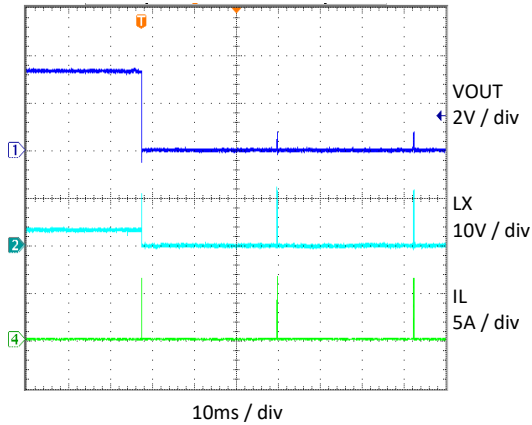

Output Short Protection Recovery

$V_{IN} = 12V$, $V_{OUT} = 3.3V$, (Hiccup Mode Recovery)

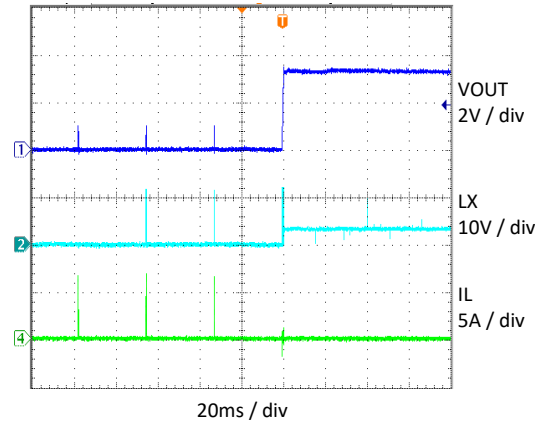

Functional Description

KTB8372 is a highly efficient, high-performance, monolithic buck regulator that operates from an input voltage of 4.7V to 18V and can output up to 5A. It integrates the main switch, synchronous rectifier switch, PWM control circuitry, V_{OUT} setting DAC, and various protection features.

Control Scheme

KTB8372 uses a proprietary adaptive on-time (AOT) PWM control scheme to maintain a nearly constant switching frequency as input voltage and output voltage vary. Compared to typical current-mode PWM schemes, the AOT control scheme provides quick response to line and load transients with excellent stability and wide bandwidth, thereby minimizing output voltage droop and soar for dynamic loads, even with minimal output capacitance. The adaptive on-time approximates fixed-frequency switching without using a fixed clock oscillator, which eliminates the need to wait for the next clock before responding to a load transient.

KTB8372 feedback loop also adds a proprietary, internally compensated, integrating error amplifier to remove the output voltage offset normally associated with other AOT, constant on-time (COT), and hysteretic architectures.

Shutdown Mode

When the EN pin is low, KTB8372 is in shutdown mode and draws extremely low supply current.

Enable

KTB8372 buck regulator is turned on and off using the EN pin. Pull EN pin high to enable the buck regulator and pull the EN pin low to disable the buck regulator.

Soft-Start

KTB8372 contains soft-start circuitry to ramp up V_{OUT} slowly in order to reduce inrush current at V_{IN} and prevent the inductor current from reaching the peak current limit during startup. During soft start, the ramp up rate of V_{OUT} is regulated to a constant value, which can be found in table 1.

Table 1. Output Voltage Ramp Rate

Nominal Output Voltage Setting (V_{OUT})	$V_{OUT} \leq 2.2V$	$2.2V < V_{OUT} \leq 3.3V$	$3.3V < V_{OUT} \leq 5.5V$
Soft-Start Ramp Rate (V_{OUT_RR})	40mV/ μ s	60mV/ μ s	100mV/ μ s

The soft-start time can be estimated by: $t_{SS} = V_{OUT} / V_{OUT_RR}$

Auto-Skip Mode and Forced-PWM Mode

KTB8372 has a default automatic skip mode. In the automatic skip mode, KTB8372 transit automatically between constant frequency PWM mode at heavy loads and PFM mode at light loads. Auto-Skip mode is helpful for applications that need high efficiency at light loads. While skipping, single pulses are evenly spaced, resulting in the lowest output ripple and noise when compared to competing “pulse-grouping” or “burst mode” devices.

In applications that are sensitive to audio noise, an Ultrasonic Mode option is available⁹. When the KTB8372 enters PFM frequency during single - pulse skipping the switching frequency will remain above the audio frequency band (20Hz to 20kHz) at very light loads.

In applications that are noise sensitive, even at light load conditions, fixed switching frequency is also desired. and the KTB8372 needs to operate in forced PWM mode. A Forced-PWM mode option is available.

Functional Description (continued)

Active Discharge Option

KTB8372 features an active discharge option, where a 200Ω (typical) on-chip resistor is connected between the LX and PGND pins. This resistor discharges the output capacitor through the inductor when KTB8372 is disabled. KTB8372 can be factory trimmed to Active Discharge. Please contact a Kinetic Technologies representative for ordering information.

Active Discharge Option Input Under-Voltage Lockout (UVLO)

When the input voltage (V_{IN}) is below the under-voltage lockout threshold (V_{UVLO}), the buck is disabled. When V_{IN} rises above V_{UVLO} , and if the buck is enabled, the default soft-start ramp begins.

Over-Current Protection (OCP)

KTB8372 features high-side switch peak-current limit and low-side switch valley-current limit, which protect the integrated FETs and inductor during over-current faults. The current limits control the buck's switching on a cycle-by-cycle basis and have a higher priority than the regulation threshold and adaptive on-time. When either high-side or low-side FET current reaches their respective over-current limiting threshold, high-side FET is turned off and will be kept off for at least 50ns, while low-side FET is turned on. The high-side FET can only be turned back on until the low-side FET current drops below the valley current limit. During sustained over-current faults, the output voltage typically droops below the regulation threshold.

Output Short-Circuit Protection

During an over-current event, when 8 consecutive (interval time minimum than 2μs typical) OCP events are detected, KTB8372 will enter hiccup mode and pause all switching. The buck regulator attempts to soft-start after 20ms, if the fault persists, the buck regulator once again enters hiccup mode and periodically re-attempts soft-start until the fault is removed. The low duty-factor during hiccup mode prevents the IC from getting hot.

Thermal Shutdown

KTB8372 is turned off by an internal thermal shutdown when the junction temperature exceeds the thermal shutdown threshold (150°C typical). The device restarts when the junction temperature drops by 20°C.

Trim Options

KTB8372 are factory trimmed using one-time programmable (OTP) registers. Standard versions are available for various default output voltage settings and modes – see the *Ordering Information* section. Contact Kinetic Technologies local representative for availability of versions with alternative default settings.

Applications Information

Recommended Inductors

The selection of the inductor affects the steady-state operation as well as transient behavior and loop stability. The three most important inductor specifications to consider are inductor value, DC resistance (DCR), and saturation current rating. Higher inductance gives lower inductor current ripple, while lower inductance usually gives faster load transient response. KTB8372 is trimmed for inductors with nominal inductance of 0.8μH to 6.5μH. Select an inductor with a saturation current rating that is higher than KTB8372 peak current limit. Also, choose an inductor with sufficient temperature-rise current rating to satisfy the RMS load-current of the application. Consider the inductor's resistance since these will affect efficiency. Larger physical case-sizes, good winding designs, and better magnetic materials can increase efficiency.

Recommended Capacitors

Ceramic input and output capacitors with X5R or X6S or X7R are recommended due to their low ESR, low ESL, low temperature coefficients, and small physical sizes. Consider the voltage rating, size, and DC bias derating characteristic of the capacitor.

Input Capacitor

Choose an input capacitor with voltage rating of 25V or more, 10μF nominal capacitance or more, and 0805 case-size or larger. Larger values and larger case-size provide more effective capacitance when considering the DC bias derating characteristic of the capacitor. If the application's input voltage is supplied through a connector or a cable, add additional bypass capacitance where V_{IN} first arrives to the PCB.

Output Capacitors

Choose output capacitors with voltage rating of 10V or more, 22μF total nominal capacitance or more, and 0805 case-size or larger. Consider the V_{OUT} setting of the regulator and how case size has a significant impact on DC bias derating. At high V_{OUT} settings, more total nominal capacitance is needed to achieve the same effective capacitance compared to lower V_{OUT} settings.

For the very best possible load transient response, use multiple capacitors in parallel to achieve sufficient total effective output capacitance:

$$C_{OUTEFFECTIVE} \geq \frac{L \times I_{STEP}}{33m\Omega \times (V_{IN} - V_{OUT})}$$

where I_{STEP} is the largest load transient step in the application, and 33mΩ is constant set by internal control circuit. Please note that the above formula is already guard-banded by a margin of 2x to accommodate capacitor and inductor tolerances and the variability of a transient arrival time with respect to the switching cycle of the regulator.

If needed, the total effective output capacitance can be distributed by placing additional capacitors remotely at the point of load. In applications where transient performance is less critical, especially when V_{IN} minus V_{OUT} is small, it is acceptable to reduce the total effective output capacitance to save board space and cost at the expense of load transient droop and soar.

Applications Information (continued)

As a design example, consider a system with $V_{IN} = 12V$ (min), $V_{OUT} = 1.8V$, and $I_{STEP} = 5A$ (max):

$$C_{OUT_EFFECTIVE} \geq \frac{1\mu H \times 5A}{33m\Omega \times (12V - 1.8V)} \cong 15\mu F$$

In this example, choose output capacitors with total effective capacitance of $14\mu F$ or more at a DC bias of $1.8V$. A single $15\mu F$ capacitor will not be enough when considering its DC bias characteristic, per Figure 1. At $1.8V$ bias, it retains only about $8\mu F$; therefore, for best transient response, use two of these capacitors in parallel for a total effective capacitance of $16\mu F$.

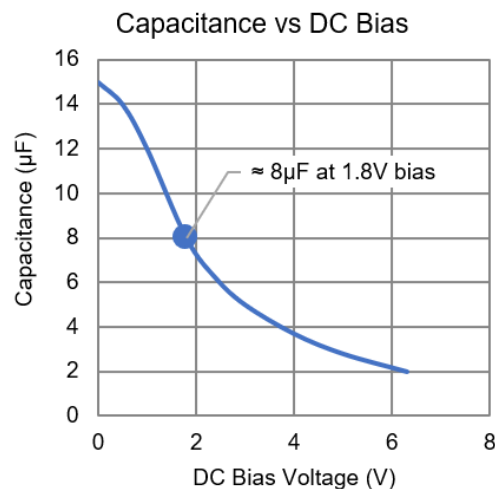

Figure 1. Typical DC Bias Derating Characteristic of an Example $15\mu F$ Ceramic Capacitor.

Recommended PCB Layout

KTB8372 PCB layout is optimized for small footprint, low EMI, and good performance. The example follows the below PCB layout recommendations:

1. Connect the input capacitor C_{IN} as close as possible to the V_{IN} and $PGND$ pins using top-side thick metal traces.
2. Connect the ground terminals of output capacitors C_{OUT} as close as possible to the ground terminal of C_{IN} and the $PGND$ pins using top-side metal.
3. Connect the Boost capacitor as close as possible to the Boost pin and Lx pin of the chip.
4. Connect the local top side $PGND$ island to the PCB ground plane using multiple parallel vias.
5. Do not connect the $AGND$ pins directly to the top side $PGND$. Instead, connect the $AGND$ pins to the PCB ground plane using their own vias.
6. Connect the inductor to the LX pins with a wide trace.
7. Connect the V_{OUT} terminals of the inductor to the output capacitors with a wide and short trace.
8. Route the V_{OUT} sense trace from C_{OUT} to the V_{OUT} pin with care to keep it away from noisy traces, especially the LX trace. Additionally, use ground fill to shield noise from coupling into the V_{OUT} sense.

Packaging Information

UQFN2.22.5-11 (2.2mm x 2.5mm x 0.55mm)

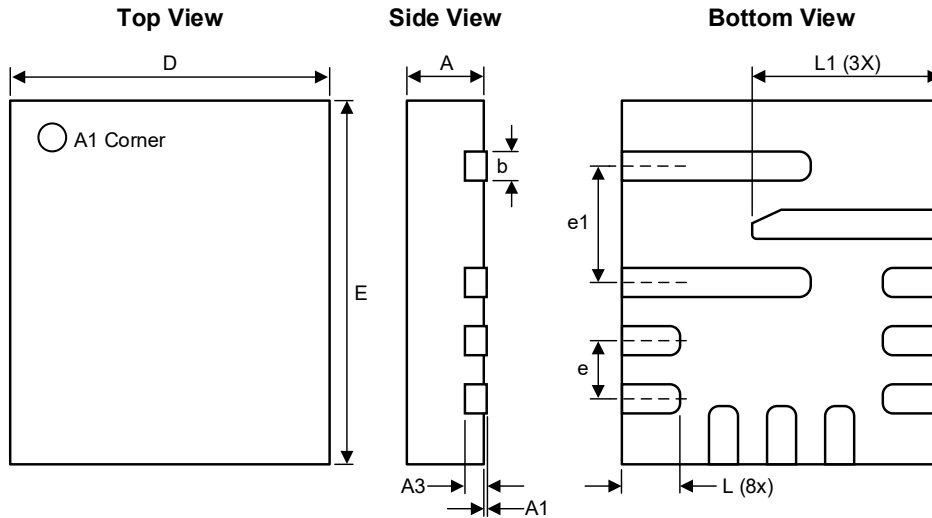

Dimension	mm		
	Min.	Typ.	Max.
A	0.50	0.55	0.60
A1	0.00	0.02	0.05
A3	0.150 REF		
b	0.15	0.20	0.25
D	2.10	2.20	2.30
E	2.40	2.50	2.60
e	0.40 BSC		
e1	0.80 BSC		
L	0.35	0.40	0.45
L1	1.25	1.30	1.35

Recommended Footprint

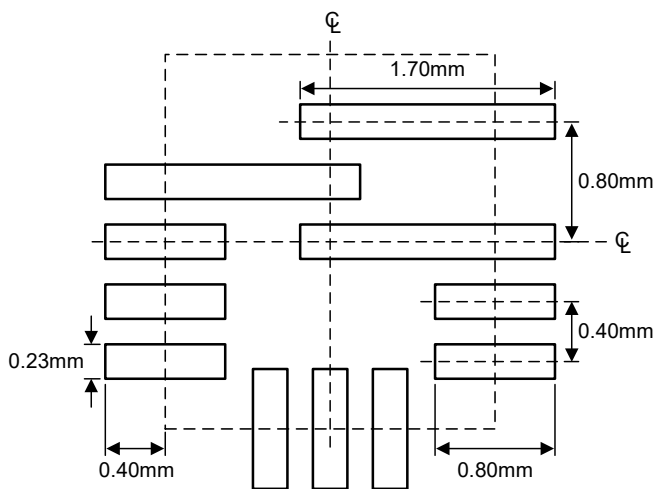

Kinetic Technologies cannot assume responsibility for use of any circuitry other than circuitry entirely embodied in a Kinetic Technologies product. No intellectual property or circuit patent licenses are implied. Kinetic Technologies reserves the right to change the circuitry and specifications without notice at any time.