

## WLCSP34-12

**Package Code: VA**

WLCSP34-12 (1.570mm x 1.170mm x 0.620mm)

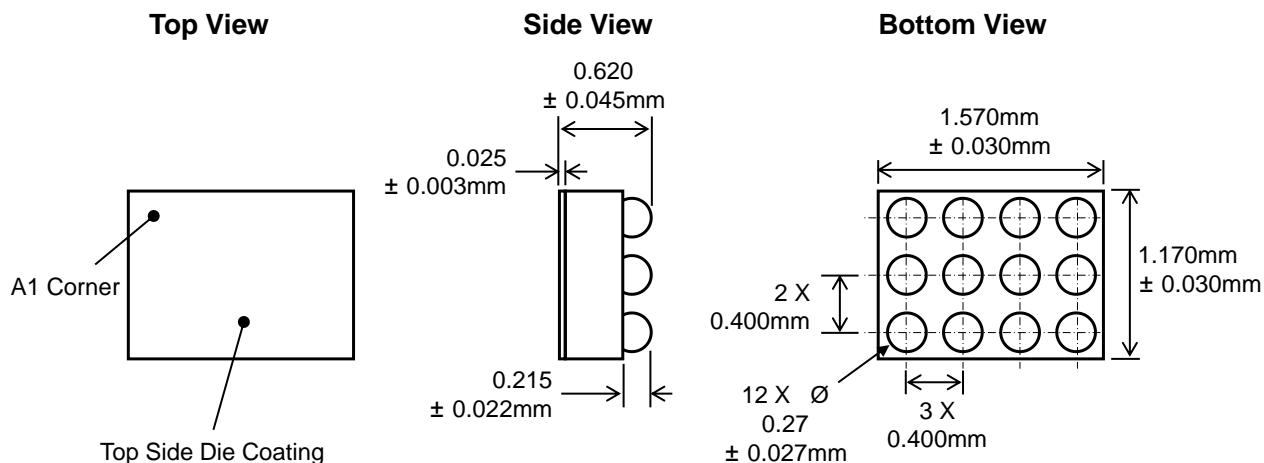

### Recommended Footprint

(NSMD Pad Type)

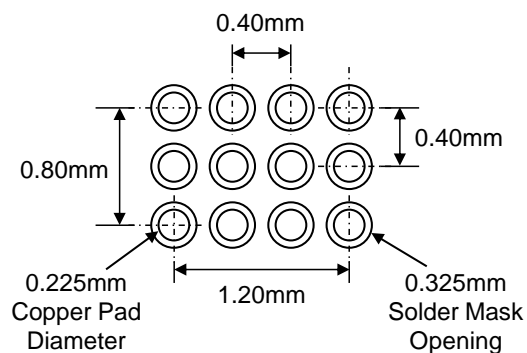

\* Dimensions are in millimeters.

Kinetic Technologies cannot assume responsibility for use of any circuitry other than circuitry entirely embodied in a Kinetic Technologies product. No intellectual property or circuit patent licenses are implied. Kinetic Technologies reserves the right to change the circuitry and specifications without notice at any time.